



Series 935B



Now with Remote
Timer Start and
Fully DIN-a-mite®
Compatible

Temperature Controller with Countdown Timer

User Levels:

- New User Go to page 2
- Experienced User / Set-Up Go to page 11
- Expert User Go to page 51

Installers:

- Mounting Go to page 40
- Wiring InformationGo to page 44



**TOTAL
CUSTOMER
SATISFACTION**

3 Year Warranty

ISO 9001



Registered Company
Winona, Minnesota USA



U.S. English

1241 Bundy Boulevard, P.O. Box 5580, Winona, Minnesota USA 55987-5580
Phone: +1 (507) 454-5300, Fax: +1 (507) 452-4507, <http://www.watlow.com>

0600-0015-0001 Rev C

July 2000

Supersedes: 0600-0015-0001 Rev B

\$15.00



Safety Alert
CAUTION or
WARNING

Safety Information in this Manual

Note, caution and warning symbols appear throughout this book to draw your attention to important operational and safety information.

A “NOTE” marks a short message to alert you to an important detail.

A “CAUTION” safety alert appears with information that is important for protecting your equipment and performance.

A “WARNING” safety alert appears with information that is important for protecting you, others and equipment from damage. Pay very close attention to all warnings that apply to your application.

The  symbol (an exclamation point in a triangle) precedes a general CAUTION or WARNING statement.

The  symbol (a lightning bolt in a lightning bolt in a triangle) precedes an electric shock hazard CAUTION or WARNING safety statement.



Electrical Shock
Hazard

CAUTION or
WARNING

Technical Assistance

If you encounter a problem with your Watlow controller, review all configuration information to verify that your selections are consistent with your application: inputs; outputs; alarms; limits; etc. If the problem persists after checking the above, you can get technical assistance by calling your local Watlow representative (see back cover of this manual), or in the U.S., dial +1 (507) 494-5656. For technical support, ask for an Applications Engineer.

Please have the following information available when you call:

- Complete model number
- All configuration information
- User’s Manual
- Diagnostic menu readings

Warranty and return information is on the inside back cover of this manual.

Your Comments

Your comments or suggestions on this manual are welcome. Please send them to the Technical Literature Team, Watlow, 1241 Bundy Boulevard, P.O. Box 5580, Winona, Minnesota, 55987-5580 U.S.; Telephone: +1 (507) 454-5300; fax: +1 (507) 452-4507.

Copyright July 2000 by Watlow, Inc., with all rights reserved. (1950)



Where to find it...

Table of Contents

Item	Page
Introduction	4
How Keys Work	6
Begin Controlling	8
Set Point Change	9
Simple Error / Response	10
Software Map; Learn	11
Operations Menu; Learn	12
PID Menu; Learn	14
Configuration Menu; Learn	18
Lockout Functions	20
Setting Up Inputs and Outputs	22
Using Remote Timer Start Input	24
Front Panel Lockout	25
Alarms; Learn	26
Alarms; Setting and Clearing	28
Timer; Learn	30
Timer; Setting	32
Timer Example	33
Auto-tuning	34
PID Fine tuning	35
Calibrating	36
Errors and Troubleshooting	38
Mounting	40
Dimensions	41
Installing	42
Terminal Block Removal	43
Wiring	44
Wiring Examples	45
Glossary	46
Index	47
Specifications	48
Ordering Information	49
Declaration of Conformity	50
Advanced Software Map	51
Warranty>Returns	Inside Back Cover
How to Reach Us	Back Cover

Table #Page

1	Output Functions	5
2	Error Messages & Action	10
3	Software Organization	11
4	Operations Menu Overview	13
5	PID Menu Overview	16
6	Configuration Overview	18
7	Lockout Options	21
8	Setting Inputs & Outputs	23
9	Using Front Panel Lock	25
10	Alarm Functions	27
11	More Alarm Functions	29
12	Timer Functions/Settings	31
13	Possible Error Codes	39
14	Troubleshoot Outputs	39
15	Input Range Information	49

Figure #Page

1	Input & Output Overview	5
2	Front Panel Functions	7
3	Begin Controlling	8
4	Changing the Set Point	9
5	Front Panel Lock Wiring	25
6	Auto-tuning	34
7	Calibrating	36
8	Panel Cut-out Dimensions	40
9	Knockout Template	40
10	Dimensions	41
11	Case Top View & Collar	42
12	NEMA 4X/IP65 Seal	42
13	Terminal Block Removal	43
14	Wiring	44
15	System Wiring Example	45
16	Ladder Diagram Example	45



Introduction

Welcome to the Watlow Series 935B!

General Description

The Series 935B is a temperature controller with countdown timer for industrial, commercial, or scientific applications. It offers 1/32 DIN panel-mounting, digital indication, single temperature sensor input from a thermocouple or RTD, and dual control outputs. Both outputs are fully *DIN-a-mite*[®] compatible, and may operate in combinations of heat or cool, and alarm or timer.

Special Features

- Easy to use operator interface and user's manual
- Compact panel footprint; 1/32 DIN size
- Water and corrosion proof; NEMA 4X / IP65 rated
- Reliable; built to UL, CUL approved safety standards with a three year warranty
- Accuracy with economy
- Universal power supply for worldwide application

Unique Features

The Series 935B is configured with dual dc *DIN-a-mite*[®] compatible control outputs and a separate logic input for remote timer start or front panel lock. The Series 935B timer functions include heat/timer or cool/timer countdown modes in hours:minutes or minutes:seconds.

Figure 1 - Series 935B Input and Output Overview



Single Input

Type J, K, T, N, S, E Thermocouple, 1° RTD, or 0.1° RTD

Output 1

Switched dc

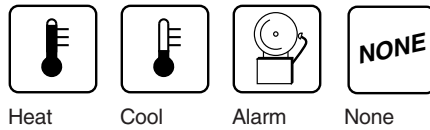

Heat Cool Alarm None

Output 2

Electromechanical Relay, Switched dc or Solid-state Relay

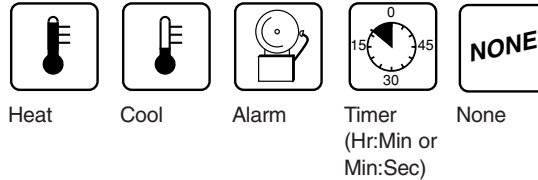

Heat Cool Alarm Timer None
(Hr:Min or Min:Sec)

- The function of Output 1 determines the options available for Output 2.
- First select the function of Output 1. Refer to the table (right), then select the function of Output 2.

Table 1 - Valid Output Functions

First select Output 1:	Then select Output 2:
Heat	None, Cool, Alarm, Timer
Cool	None, Heat, Alarm, Timer
Alarm	None, Heat, Cool
None	Heat, Cool, Alarm



Press & read or press & change

Reading or Changing Information is Easy





You can simply:

- Read the normally displayed actual temperature,

or...

- Press and hold **SET** to read the set point,

or...

1. Press and hold  and  simultaneously for three seconds to move to a software menu.
2. Press and hold **SET** to display a choice or value.
3. While continuing to press **SET**, press  or  to choose new data or select a new value.
4. Release **SET** and the arrow key to complete the change.

NOTE: The normally displayed actual temperature and set point can be altered to show different combinations of actual temperature, set point temperature, or time in hours:minutes or minutes:seconds. See **DISP** p. 18.

Figure 2 - Series 935B Front Panel Functions

Seven-segment alphanumeric display:

- Shows process value, set point information, time, or
- Shows prompt name or value, depending on the key combination pressed.

Set Key: 

- Configurable to shift between normally-displayed value and set values. See [EISP](#), p.18.
- Clears a latched alarm.

LED 1:

Lit when Output 1 is active.

LED 2:

Lit when Output 2 is active.

RDY:

Lit when the process temperature is inside the timer ready band.

**Up /  (Increment)
Down /  (Decrement) Arrow Key:**

- Selects new information when Set Key is pressed.
- Steps through software menus and parameters.
- Starts and stops the timer.

- To set up the control, go to the Easy Software Map, p. 11.





Begin Controlling

To Begin Controlling:

1. Apply power to the system.
A properly-wired Series 935B will begin controlling the thermal system as soon as you apply power to it.
 2. Look at the Series 935B's display. It is reading actual temperature, set point temperature, or time.
- To change set point, go to p. 9.
 - The Series 935B will auto-tune when you tell it to, go to p. 34.
 - If you see an error, go to p. 10.

Figure 3 - Begin Controlling

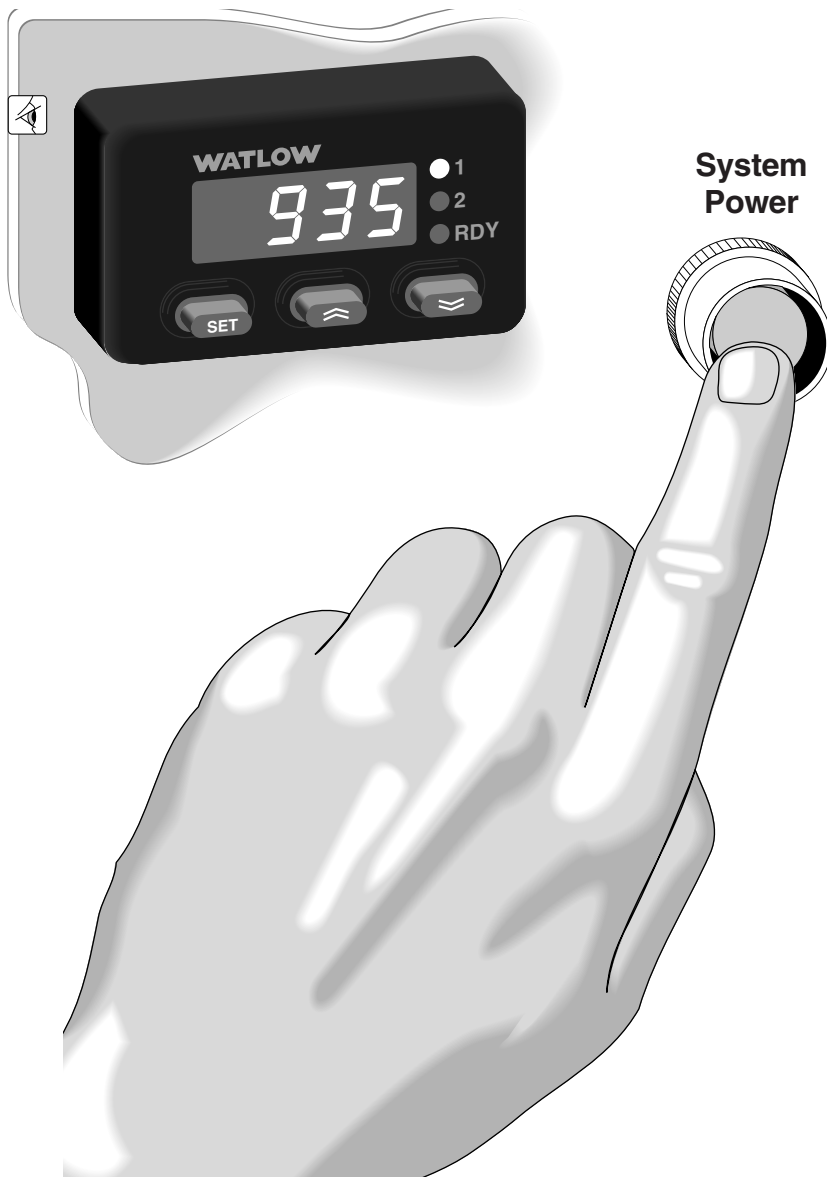



Change Set Point

To Change the Set Point:

Your Series 935B displays the actual process temperature when it comes from the factory. You can change it to normally display the set point or time. Go to p. 18, see **ISP**.

1. Press and hold **SET**.
2. Press one of the arrow keys to alter the set point either upward or downward.
3. Release **SET** to complete the change.

Figure 4 - Changing the Set Point



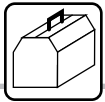









Respond to a simple error

If You See An Error Code:

1. Be aware that most errors are input (sensor) related.
2. Read the table below and follow its recommendations.

Table 2 - Error messages and recommended action

Display	Probable Cause	Recommended Action
	Reversed thermo-couple connection + to -.	Change the sensor leads on Terminals 1 and 2.
	Sensor type mismatch or open RTD.	Go to  prompt, check selection (see p. 22), or check RTD, replace as necessary.
	Sensor type mismatch.	Go to  prompt, check selection (see p. 22).
	Open Thermocouple, bad connection, or broken wire.	Check the sensor, replace as necessary.
	Electrical noise.	Cycle power to system. See if error clears. Check system for electrical interference.
	Control is inoperable.	Check for line voltage at terminals 7 and 8.

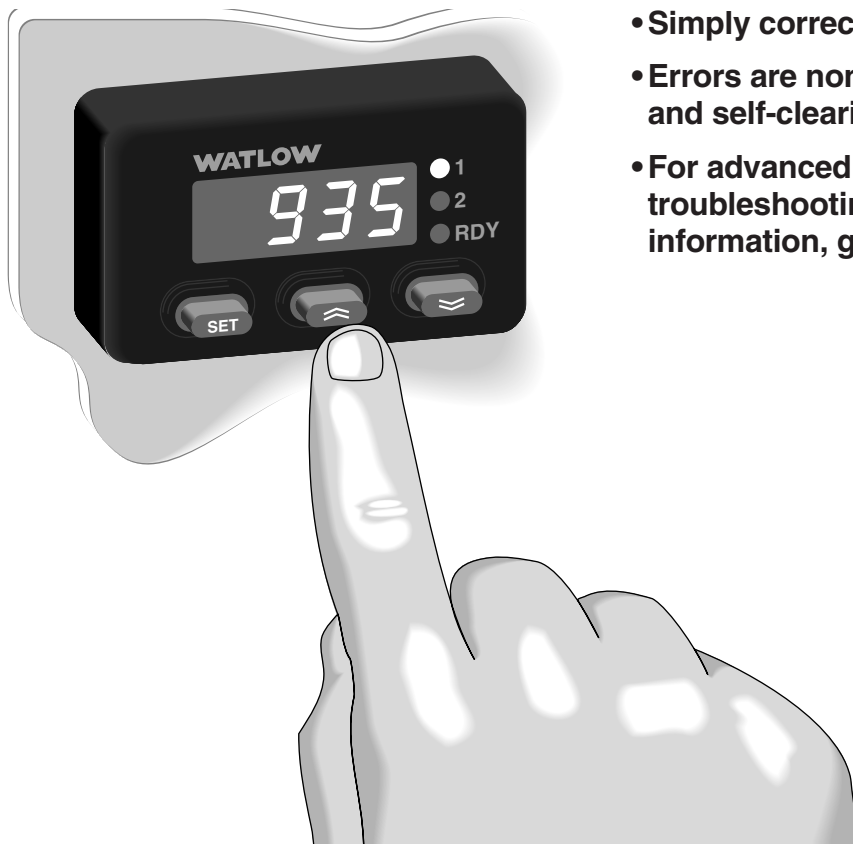

- **Simply correct the cause.**
- **Errors are non-latching and self-clearing.**
- **For advanced error and troubleshooting information, go to p. 39.**

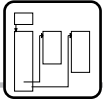

Learn Easy Software Map

Software Organization

- The Series 935B has three primary menus in addition to a normal display.
- The software reverts to the normal display after 60 ± 5 sec. with no key action.

Table 3 - Software Organization

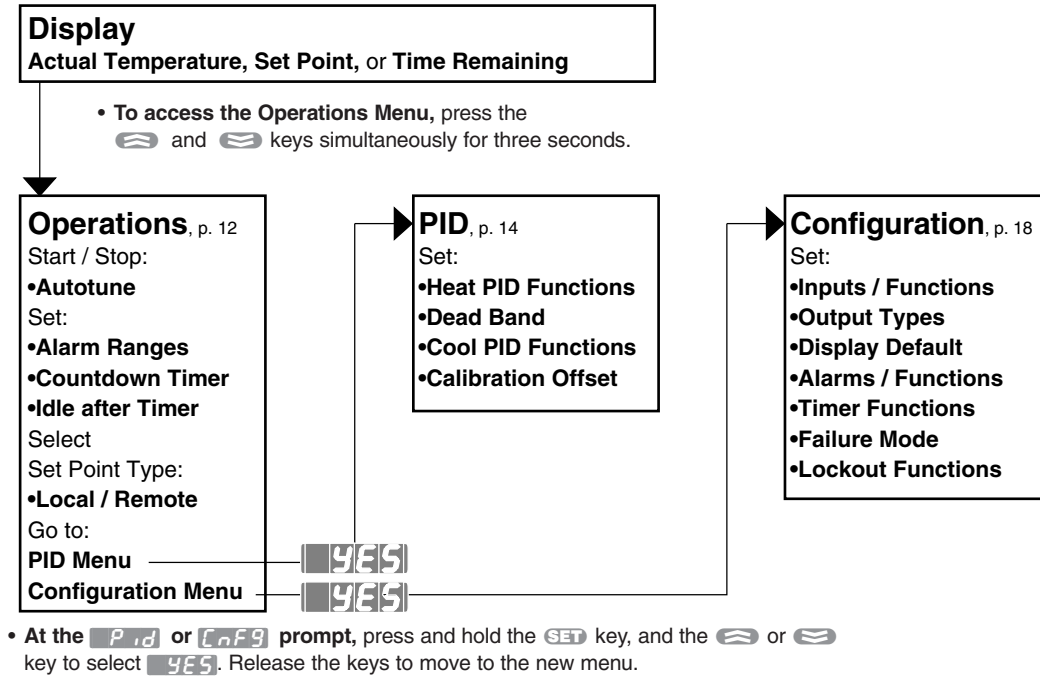



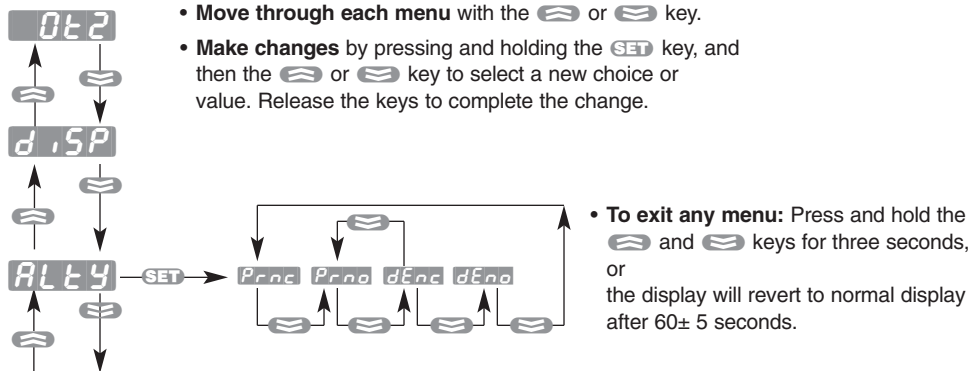

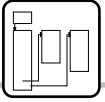













Navigation Example





Learn the Operations Menu

The Series 935B Operations Menu is the first menu you encounter when you press the  and  keys simultaneously for three seconds. The Operations Menu provides a location to initiate the following actions or complete the following tasks:

- **Auto-tune** : Start or stop the auto-tuning process. Auto-tuning selects a set of viable proportional, integral, and derivative values for heat and/or cool output.
- **Alarm Points**,  and : Select the values for the high alarm point and the low alarm point. Alarm points, dependent on sensor type high and low ranges, reside in the Operations Menu for easy access.
- **Timer Countdown Time** : Select a countdown time value between 00:00 and 99:59 hours:minutes or minutes:seconds. Time interval choices  and  reside in the Configuration Menu for Output 2.
- **Idle Set Point** :  or an adjustable value between  and . Choose to have the Idle Set Point track , or equal, the Primary Set Point; or select an Idle Set Point value in °F or °C between the range low  and range high  values. The Idle Set Point is active both before and after the timing sequence. The normal or Primary Set Point controls during the timing sequence.
- **Go to the PID Menu** : Choose  to proceed to the PID Menu.
- **Go to the Configuration Menu** : Choose  to proceed to the Configuration Menu.

The table on the next page presents this information in graphic form.

NOTE: Not every prompt listed here or on p. 13 in the Operations Menu will appear in your unit. Prompts vary with lockout function and output set-up. Whether or not prompts appear in the Operations Menu depends on two features of the Series 935B:



- Lockout function; the Lockout Tag  function masks prompts from view in the various menus. (If you cannot see a prompt, you can make no change.) See Using Lockout Functions, p. 20, for more information.
- Output 1 and 2 Configuration; some outputs are mutually exclusive. For example, if Output 1 is Alarm, then Output 2 cannot be Timer. Therefore, the Operations menu will have no timer-related prompts. See the Valid Output Functions Table, p. 5, or Setting Up Inputs and Outputs, p. 22.

Table 4 - Operations Menu Overview

To enter the **Operations Menu**, press the  and  keys simultaneously for three seconds.

Auto-tune - Start the auto-tune action to automatically select a set of viable PID values;

tunE will flash during auto-tuning.



NO YES

Alarm Low - Select a low alarm point, adjustable between Off, Range Low and Alarm High.



Alarm High

Alarm High - Select a high alarm point, adjustable between Alarm Low and Range High, or OFF.



Alarm Low

Countdown Timer - Select a countdown time duration.



00:00 to 99:59 Hrs:Min or Min:Sec

Idle Set Point Type - Choose to track set point, or select a separate idle set point adjustable between Range Low and Range High. When **0E1 = tHP7** or **tP7S**, view the idle set point from the set point display with a three second **SET** press.



Track Set Point Range Low Range High

PID Menu - Go to the PID Menu.



NO YES

Configuration Menu - Go to the Configuration Menu.



NO YES

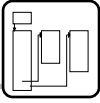

Learn the PID Menu

Choosing a PID Setting Strategy

You may rely solely on the Auto-tune **AUT** function (p. 34) and factory defaults to determine PID values for your system, or you may use auto-tuning and additional manual adjustments. You must select dead band **db** and calibration offset **CAL** values manually.

The Series 935B PID Menu is the first sub-menu you encounter after moving to the Operations Menu. The PID Menu provides a software location to select the individual heat or cool proportional band, hysteresis, and cycle time values; and the dead band, integral, derivative, and calibration offset values.

To go to the PID Menu:

1. Go first to the Operations Menu by pressing **⏪** and **⏩** simultaneously for three seconds.
2. Scroll through the Operations Menu with **⏩** until you see the **P_id** prompt.
3. While pressing **SET** to display **no**, choose **YES** with **⏪** or **⏩**.
4. Release **SET** to see the first PID prompt.

NOTE: Access to the PID Menu and the prompts there varies with lockout function and output set-up. The PID Menu is locked out when the 935B leaves the factory.

- Lockout function; the Lockout Tag **LAG** function masks menus from view (if you cannot see a prompt, you can make no change).
See Using Lockout Functions, p. 20.
- Output set-up; you must choose **HEAT** or **COOL** in either Output 1 or Output 2 to have access to the PID Menu.
With a **HEAT** only choice, **COOL** prompts are not visible, and vice versa.

See the Valid Output Functions Table, p. 5, or Setting Up Inputs and Outputs, p. 22.

NOTE: Proportional Band, Integral, Derivative, Dead Band, and Calibration Offset values are adjustable in whole or tenth °F or °C, depending on input type **In and **C_F** Celsius/Fahrenheit Configuration Menu choices.**

Setting PID Menu Values

- **Proportional Band, Heat and Cool** Pb_h and Pb_c : Select a value (degrees) to set up band on either side (\pm) of the Primary Set Point in which the heat and/or cool proportioning function(s) will be active.
For on/off control, set Pb_h or $Pb_c = 0$.
Range: 0 to 999°F/555°C, or 0.0 to 999.0°F/555.0°C
Default: 25°F/17°C, or 25.0°F/17.0°C
- **Hysteresis, Heat and Cool** hys_h and hys_c : For use with on/off control only. Select the value (degrees) for the process variable change required to re-energize the control heat and/or cool output.
For ON/off control, set Pb_h or $Pb_c = 0$.
Range: 1 to 999°F/555°C, or 0.1 to 999.0°F/555.0°C
Default: 3°F/2°C, or 3.0°F/2.0°C
- **Cycle Time**, ct_h and ct_c : Select the value (seconds) required for the heat and/or cool output(s) to complete a full ON through off cycle.
Range: Switched dc/Solid State Relay: 0.1 to 60.0 seconds
Default: 5.0 seconds
Range: Electromechanical Relay: 5.0 to 60.0 seconds
Default: 30.0 seconds
- **Dead Band** db : Dead Band adjusts the effective cool set point above the primary set point by the Dead Band value in degrees. This creates a band between the heating and cooling proportional bands where only integral and derivative activity will occur. For more information on Dead Band fine tuning, go to p. 35.
Range: 0 to 999°F/555°C, or 0.0 to 999.0°F/555.0°C
Default: 0°
- **Integral** it : Select a value (minutes/repeat) for the integral function. Integral is the inverse of Reset; $It(value) = 1/Reset(value)$.
Range: 0.00 to 99.99 minutes/repeat
Default: 5.00 minutes/repeat
- **Derivative** de : Select a value (minutes) for the derivative function.
Range: 0.00 to 9.99 minutes
Default: 0.00 minutes
- **Calibration Offset** cal : Eliminates the difference between the displayed process temperature and the actual process temperature value.
Range: -999 to 9999°F/C, or -99.9 to 999.9F/C
Default: 0°

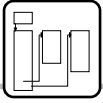

Learn the PID Menu - Details

Table 5 - PID Menu Overview

Set-Up Heat

Proportional Band Heat - Select a heat proportional band value.

Pb h	0 999	0 555	0.0 999.0	0.0 555.0
	0°F to 999°F, or	0°C to 555°C, or	0.0°F to 999.0°F, or	0.0°C to 555.0°C

Hysteresis Heat - Select a heat ON/off control switching hysteresis.

hys h	1 999	1 555	0.1 999.0	0.1 555.0
	1°F to 999°F, or	1°C to 555°C, or	0.1°F to 999.0°F, or	0.1°C to 555.0°C

Cycle Time Heat - Select a heat output cycle time.

ct h	0.1 60.0	5.0 60.0
	0.1 to 60.0 seconds (SSR or Switched dc)	5.0 to 60.0 seconds (Electromechanical Relay)

Dead Band - Select a dead band value.

db	0 999	0 555	0.0 999.0	0.0 555.0
	0°F to 999°F, or	0°C to 555°C, or	0.0°F to 999.0°F, or	0.0°C to 555.0°C

Set-Up Cool

Proportional Band Cool - Select a cool proportional band value.

Pb c	0 999	0 555	0.0 999.0	0.0 555.0
	0°F to 999°F, or	0°C to 555°C, or	0.0°F to 999.0°F, or	0.0°C to 555.0°C

Hysteresis Cool - Select a cool ON/off control switching hysteresis.

hys c	1 999	1 555	0.1 999.0	0.1 555.0
	1°F to 999°F, or	1°C to 555°C, or	0.1°F to 999.0°F, or	0.1°C to 555.0°C

Cycle Time Cool - Select a cool output cycle time.

ct c	0.1 60.0	5.0 60.0
	0.1 to 60.0 seconds (SSR or Switched dc)	5.0 to 60.0 seconds (Electromechanical Relay)

Set-Up General

Integral Function - Select an integral value.

0.00 to 99.99 minutes/repeat

Derivative Function - Select a derivative value.

0.00 to 9.99 minutes

Calibration Offset - Select a calibration offset value.

-999° to 9999°F or C or -99.9° to 999.9°F or C

NOTE: Access to the PID Menu and the prompts there varies with lockout function and output set-up. The PID Menu is locked out when the 935B leaves the factory.

- Lockout function; the Lockout Tag function masks menus from view (if you cannot see a prompt, you can make no change). See Using Lockout Functions, p. 20.
- Output set-up; you must choose or in either Output 1 or Output 2 to have access to the PID Menu. With a only choice, prompts are not visible, and vice versa. See the Valid Output Functions Table, p. 5, or Setting Up Inputs and Outputs, p. 22.

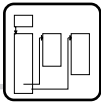

Learn the Configuration Menu

The Configuration Menu is the second sub-menu in the Operations Menu. Use it to set Inputs, Ranges, Output Types, Alarms, Timer, Failure Mode, and Lockouts.

To go to the Configuration Menu:

1. Go first to the Operations Menu by pressing and simultaneously for three seconds.
2. Scroll through the Operations Menu with until you see the **[nF9]** prompt.
3. While holding **SET** to display **no**, choose **YES** with or .
4. Release **SET** to see the first **[nF9]** prompt, **in**.
5. To leave the Configuration Menu, press and for 3 seconds.

Table 6 - Configuration Menu Overview

Input Type - Choose sensor type. See p. 23 for sensor ranges.									
J t/c	K t/c	T t/c	N t/c	E t/c	S t/c	1.0° RTD	0.1° RTD		
Celsius/Fahrenheit - Choose displayed unit of measure.									
°F	°C								
Input Range Low - Select lowest displayable set point. Ranges, p. 23.									
Select a value (lowest displayable set point) between Input Type Range Low and Input Range High.									
Input Range High - Select highest displayable set point. Ranges, p. 23.									
Select a value (highest displayable set point) between Input Type Range High and Input Range Low.									
Output 1 Function - Choose Output 1 type; see Valid Outputs Table, p. 23									
Heat	Cool	Alarm	None						
Output 2 Function - Choose Output 2 type (dependent on Output 1 choice).									
Heat	Cool	Alarm	Timer Hr./Min.	Timer Min./Sec	None				
Remote Timer Start - Choose remote timer start operation.									
Off	Front Panel Lock	Countdown Timer							
Display Default - Choose the primary (last 2 characters) and secondary (first 2 characters) default displays. Press SET to toggle to the secondary display for 15 seconds.									
No secondary Actual temp.	Actual temp. Set pnt temp.	Actual temp. Time remaining	Time remaining Actual temp.	Time remaining Set point temperature					
Alarm Type - Choose alarm type with output action.									
Process normally closed	Process normally open	Deviation normally closed	Deviation normally open						

NOTE: Access to Configuration Menu varies with lockout function. See p. 21.

Alarm Hysteresis - Choose alarm switching band.

AHYS **I** **999** **I** **555** **0.1** **999.0** **0.1** **555.0**
 1°F to 999°F, or 1°C to 555°C, or 0.1°F to 999.0°F, or 0.1°C to 555.0°C

Alarm Latch - Choose latching or non-latching alarms.

A latching alarm requires a **SET** press to clear it after the alarm condition clears.

LAT **no** **YES**
 NO YES

Alarm Silencing - Choose to silence alarms on startup, or not.

SIL = **YES** silence an alarm with a **SET** press.

SIL **no** **YES**
 NO YES

Failure Mode - Choose output action after a sensor failure.

Bumpless transfer provides a smooth transition to percent power control without output state change.

FAIL **bPLS** **-100** **100**
 Bumpless Percent Power

Timer Output Function - Choose output function for the end of the timer.

Delay ON = Turn ON, Delay Off = Turn off, Signal ON = Toggle ON, Signal off = Toggle off

tIP7 **dLon** **dLoF** **S9on** **S9oF**
 Delay on Delay Off Signal On Signal Off

Start Timer Function - Choose the start timer conditions:

tIP7d = Immediate start on a **SET** press; **rdy** = **SET** press and Actual temp. is inside the Ready Band; **rdyA** = **SET** press, plus Actual temp. is inside the Ready Band, then acknowledge with a **SET** press;

PbJr = immediate start on power-up without waiting for Ready Band temp. or a **SET** press.

Start **tIP7d** **rdy** **rdyA** **PbJr**
 Immediate Ready Ready Acknowledge Power

Timer Ready Band - If **Start** = **rdy** or **rdyA**, select ready band high/low values.

rdy **0** **999** **0** **555** **0.0** **999.0** **0.0** **555.0**
 0°F to 999°F, or 0°C to 555°C, or 0.0°F to 999.0°F, or 0.0°C to 555.0°C

Signal Time - If **tIP7** = **S9on** or **S9oF**, select a Signal ON or Signal off time duration

to trigger an annunciator or other action at completion of countdown time.

St **I** **9959**
 1 sec. to 99:59 min:sec.

Set Point Lock - Choose to lock the Primary Set Point from change, not view.

SLOC **no** **YES**
 NO YES

Lockout Tag - Choose undisplayable/unchangeable menus; **PCOR** = all locked.

LAG **PCOR** **PCO** **PCA** **PC** **POA** **PO** **PA** **P**
 COR **CO** **CA** **C** **ORA** **O** **A**

Choose the menus / function that will not be displayed, and therefore cannot be changed. P = PID Menu, C = Configuration Menu (except **LAG**), O = Operations Menu (except **CnF9**), A = Auto-tune.



Using Lockout Functions

Configuration Menu

in	Input Type
C_F	Celsius/Fahrenheit
rL	Input Range Low
rH	Input Range High
0t1 ✓	Output 1 Function
0t2	Output 2 Function
rTS	Remote Timer Start
dISP	Display Default
ALtY	Alarm Type
AhYS	Alarm Hysteresis
LAt	Alarm Latch
SIL	Alarm Silencing
FAIL	Failure Mode
tIPt	Timer Function
St-t	Start Timer
rdY	Timer Ready Band
St	Signal Time
SLOC ✓	Set Point Lockout
tA9 ✓	Lockout Tag

Key Lockout Information

The Series 935B offers three different security, or “lockout,” options. Set up one or all three lockout options in the Configuration Menu.

- **Front Panel Lock** **FPL** uses an input for an external hardware switch; it requires wiring, see p. 25. Choose Front Panel Lock **FPL** from the **rTS** choices.
- **Choose Set Point Lock** **SLOC** as the simplest lockout option. It locks the Primary Set Point from change, but not from view.
- **Choose the Security Tag** **tA9** as a means of masking the Series 935B software menus from view. By selecting all or part of the four-digit binary acronym, **PCOR** (Proportional / Configuration / Operation / Auto-tune), you can choose to mask those items from view, and therefore from change. For example: In the Configuration Menu **tA9** set-up, if you can see the P, the operator cannot see the PID menu.
- Exceptions to **PCOR tA9** are:
 - “C” does not lock out **tA9**.
 - “O” does not lock out **LnF9**.

Table 7 - Series 935B Lockout Options

Three Lockout Options Detailed



Front Panel Lockout



FPL



Set Point Lockout



no YES

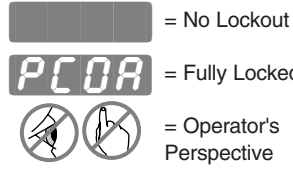

Security Tag



P C O

= No Lockout

= Fully Locked

= Operator's Perspective

	FPL	no	YES	P	C	O	A
View Process	Yes	Yes	Yes	Yes	Yes	Yes	Yes
View Set Point	Yes	Yes	Yes	Yes	Yes	Yes	Yes
Change Set Point	No	Yes	No	Yes	Yes	Yes	Yes
Auto-tune	No	Yes	Yes	Yes	Yes	Yes	No
View, Change Operation Menu	No	Yes	Yes	Yes	Yes	No	Yes
View, Change Configuration Menu (except tag)	No	Yes	Yes	Yes	No	Yes	Yes
View, Change PID	No	Yes	Yes	No	Yes	Yes	Yes

P = PID Menu,
 C = Configuration Menu
 (except TAG),
 O = Operations Menu
 (except [nFg]),
 A = Auto-tune

Note: Front Panel Lockout requires an external hardware switch. For FPL set-up and wiring information, see p. 25. For more wiring information, see p. 45.



Setting Inputs and Outputs

Configuration Menu

In ✓
Input Type
C_F ✓
Celsius/Fahrenheit
rL ✓
Input Range Low
rh ✓
Input Range High
0t1 ✓
Output 1 Function
0t2 ✓
Output 2 Function
rTS ✓
Remote Timer Start
dISP ✓
Display Default
ALtY
Alarm Type
AhYS
Alarm Hysteresis
LAE
Alarm Latch
SIL
Alarm Silencing
FAIL
Failure Mode
t1P7
Timer Function
Strt
Start Timer
rdY
Timer Ready Band
St
Signal Time
SLOC
Set Point Lockout
LAG
Lockout Tag

Key Input/Output Set-up Information

- All initial input and output set-up occurs in the Configuration Menu.
- Indication of °C or °F units of measure occurs only in the **C_F** prompt.
- Sensor input type minimum and maximum range (see p. 53) is further defined with Range Low **rL** and Range High **rh** to set the working span of set points and remote set point scaling.
- Output 1 and Output 2 configure the prime functions of the Series 935B, they are the “golden” prompts.
- Output 1 must be heat or cool to use Output 2 as a timer.
- Front Panel Lock **FPL** requires a customer-supplied external switch wired on Terminals 3 and 4. Switch open = unlocked; closed = locked. Select this feature with **rTS** = **FPL**.
- Remote Timer Start requires a customer-supplied switch on Terminals 3 and 4. Switch closed=start. Select this feature with **rTS** = **tP7r**.
- Output 2 sets timer interval in hours:minutes **tH77** or minutes:seconds **tP7S**.
- Display Default **dISP** lets you choose the primary (last 2 characters) and secondary (first 2 characters) default displays. Press **SET** to toggle to the secondary display for 15 seconds.
 - RC** = Normal Display: Actual Temperature
Secondary: None
 - RCSP** = Normal Display: Set Point Temperature
Secondary: Actual Temperature
 - RCt1** = Normal Display: Time Remaining
Secondary: Actual Temperature
 - tRC** = Normal Display: Actual Temperature
Secondary: Time Remaining
 - tRSP** = Normal Display: Set Point Temperature
Secondary: Time Remaining

NOTE: Access to Configuration Menu varies with lockout function. See p. 21.

Configuration Menu

Table 8 - Setting Inputs and Outputs

Input Type - Choose sensor type.

in **J** **H** **t** **n** **E** **S** **rtd** **rtd**
 J t/c K t/c T t/c N t/c E t/c S t/c 1.0° RTD 0.1° RTD

Input Range Information

J t/c:	32	to	1382°F	or	0	to	750°C
K t/c:	-328	to	2282°F	or	-200	to	1250°C
T t/c:	-328	to	662°F	or	-200	to	350°C
N t/c:	32	to	2282°F	or	0	to	1250°C
S t/c:	32	to	2642°F	or	0	to	1450°C
E t/c:	-328	to	1470°F	or	-200	to	799°C
1° RTD (DIN):	-328	to	1292°F	or	-200	to	700°C
0.1° RTD:	-99.9	to	999.9°F	or	-99.9	to	700.0°C

Celsius/Fahrenheit - Choose displayed unit of measure.

C-F **°F** **°C**
 °F °C

Input Range Low - Select lowest displayable Set Point, dependent on **in**.

rl **in** **rh** Select a value (lowest displayable set point) between Input Type Range Low and Input Range High.

Input Range High - Select highest displayable Set Point, dependent on **in**.

rh **rl** **in** Select a value (highest displayable set point) between Input Type Range High and Input Range Low.

Output 1 Function - Choose Output 1 type.

Out 1 **HEAT** **COOL** **ALARM** **none**
 Heat Cool Alarm None

- The function of Output 1 determines the options available for Output 2.
- First select the function of Output 1. Refer to the table (right), then select the function of Output 2.

Valid Output Functions

First select Output 1:	Then select Output 2:
Heat	None, Cool, Alarm, Timer
Cool	None, Heat, Alarm, Timer
Alarm	None, Heat, Cool
None	Heat, Cool, Alarm

Output 2 Function - Choose Output 2 type (dependent on Output 1 choice).

Out 2 **HEAT** **COOL** **ALARM** **timer** **timer** **none**
 Heat Cool Alarm Timer Timer None
 Hr./Min. Min./Sec

Remote Timer Start - Choose Off, Front Panel Lock, or Timer (Hrs:Min).

rts **OFF** **FPL** **timer**
 Off Front Panel Lock Timer

Display Default - Choose the primary (last 2 characters) and secondary (first 2 characters) default displays. Press **SET** to toggle to the secondary display for 15 seconds.

dISP **Ac** **AcSP** **Act** **tAc** **tISP**
 No secondary Actual temp. Actual temp. Time remaining Time remaining
 Actual temp. Set pnt temp. Time remaining Actual temp. Set point temperature



Using Remote Timer Start Input

Configuration Menu

- In ✓
Input Type
- C-F ✓
Celsius/Fahrenheit
- rL
Input Range Low
- rH
Input Range High
- 0t1 ✓
Output 1 Function
- 0t2
Output 2 Function
- rTS ✓
Remote Timer Start
- dISP
Display Default
- FRIL
Failure Mode
- SLOC
Set Point Lockout
- TAG
Lockout Tag
- Operations**
- Menu**
- Aut
Auto-tune
- L-r
Local / Remote
- PID
PID
- CNFG
Configuration

To Set Up Remote Timer Start...

1. Wire the control per the example below and the information on p. 44-45.
2. Make In and C-F choices, then
3. Select 0t1 at the rTS prompt.
4. Close switch to remotely start the timer.

Figure 5 - Remote Timer Start Wiring

See p. 45 for more wiring information.

(Closed switch = Starts Timer)

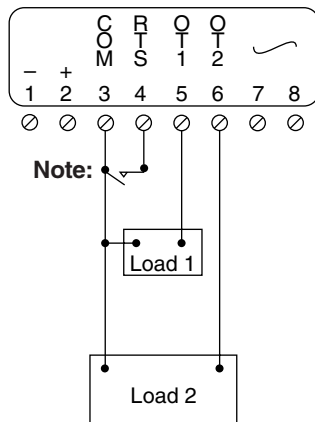

Note:

Note: Customer -supplied N.O. momentary switch.



WARNING: All wiring and fusing must conform to local and national electric codes. Contact local authorities for further information. Failure to comply with electric codes could result in injury or death, or damage to property.



Using Front Panel Lockout

Configuration Menu

- In
Input Type

- C_F
Celsius/Fahrenheit

- rL
Input Range Low

- rH
Input Range High

- 0t1
Output 1 Function

- 0t2
Output 2 Function

- rTS ✓
Remote Timer Start

- dISP
Display Default

- ⋮

- FRIL
Failure Mode

- tIPN
Timer Function

- StRT
Start Timer

- rdy
Timer Ready Band

- St
Signal Time

- SLOC
Set Point Lockout

- tRg
Lockout Tag

To Set Up Front Panel Lock...

1. Install an external switch.
2. Wire the control per the example below and the information on p. 44-45.
3. Go to [nF9] menu, then rTS prompt, and choose FPL.

Table 9 - Using Front Panel Lock



rTS = FPL	
View Process	Yes
View Set Point	Yes
Change Set Point	No
Auto-tune	No
Reset Alarm	Yes
View or Change Operation Menu (Except Config. Menu)	No
View or Change Configuration Menu (Except Tag)	No
View or Change PID Menu	No

rTS FPL

Figure 6 - Front Panel Lock Wiring

See p. 44 and 45 for more wiring information.

(Closed switch = locked panel)

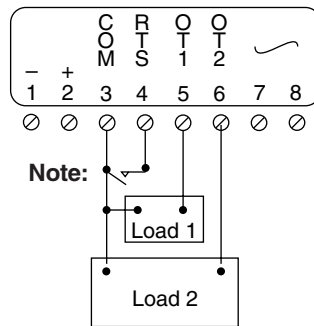

Note:

Note: Customer-supplied two-position switch.



Learning Alarms

Configuration Menu

In	
Input Type	
C_F	
Celsius/Fahrenheit	
rL	
Input Range Low	
rh	
Input Range High	
0t1	
Output 1 Function	
0t2	
Output 2 Function	
rTs	
Remote Timer Start	
dISP	
Display Default	
ALTY ✓	
Alarm Type	
RhYS ✓	
Alarm Hysteresis	
LAL ✓	
Alarm Latch	
SIL ✓	
Alarm Silencing	
FAIL	
Failure Mode	
Operations Menu	
Aut	
Auto-tune	
ALO ✓	
Alarm Range Low	
AhI ✓	
Alarm Range High	
Pid	
PID	
CnFg	
Configuration	

Key Alarm Information

Alarms signal an excursion from normal operating conditions. In general, audible alarms or lights connected to alarm outputs will signal a problem. In the 935B the front panel LED “1” or “2” indicates an alarm with **hI** or **LO** flashing on the main display.

- **Process alarms** use absolute high and low values to trigger an alarm. Use this alarm type if your process may be subject to temperatures that it must not exceed. Use **RhI** and **ALO** to set alarm points at or near these values. See Table 10: **ALTY**, next page.

- **Deviation alarms** are triggered by a deviation from the set point. The alarm high value **RhI** is the deviation above set point, and the low value **ALO** is the deviation below set point. Whenever the set point is adjusted, the alarm settings are relative to that value. Deviation alarms use the currently controlling set point, whether primary, remote, idle, or 90% of primary, during auto-tuning. See Table 10: **ALTY**, next page.

- **Normally Open, dEno or Prno, Alarms energize** the alarm output when an alarm condition occurs, and de-energize it when cleared. Use this type to activate external devices such as audible alarms or lights. See Table 10: **ALTY**, next page.

- **Normally Closed, dEnc or Prnc, Alarms de-energize** the alarm output when an alarm condition occurs, and energize it when the alarm is cleared. Use this type as a “deadman” switch where system continuity is required for operation. See Table 10: **ALTY**, next page.

For example, by running the control output through the alarm output, you can set a normally closed process alarm to disable the process when the process exceeds the alarm set point. The alarm output will be off when power is off.

- **Alarm Hysteresis** sets a point the process must pass on a return (from an alarm condition excursion) to the **ALO** and **AhI** points before the alarm can clear. This prevents the alarm output from “chattering” if the process is hovering around the alarm set point. See Table 10: **RhYS**, next page.

- **Latching Alarms** require the operator to clear them with a **SET** press after the process returns to a safe, or non-alarm condition. Non-latching alarms self-clear. See Table 11: **LAL**, p. 29.

- **Silenced Alarms** provide a means to clear the alarm output with a **SET** press even if the alarm condition still exists. The flashing **hI** or **LO** message will persist until the alarm condition ceases. See Table 11: **SIL**, p. 29. If **SIL = YES**, alarms are disabled (no message or output) on startup until the safe area is reached.

- **Alarm High and Low Points, RhI and ALO**, in the Operations menu determine where alarms will trigger. Alarm hysteresis **RhYS** determines where an alarm condition clears. See Table 11, page 29.

- **To Clear an Alarm** that is latched or “silence-able” requires the operator to press the **SET** key after the process returns to a safe, or non-alarm condition. Non-latching alarms self-clear. See Table 11: **LRL** and **SIL**, p. 29.

Table 10 (below) and Table 11 (p. 29) illustrate the Series 935B alarm features.

Table 10 - Alarm Functions

Alarm Type →	Deviation Alarm		Process Alarm	
	dEnc	dEno	Prnc	Prno
Non-Alarm State LED off Alarm Output:				
Alarm State LED on Alarm Output Status:				
Silenced-Alarm State LED off Alarm Output Status:				
Power-Off State LED off Alarm Output Status:				
Function				
Alarm Hysteresis Ahty	Alarm Hysteresis is the change in the process variable (actual) required to clear the alarm relay after an alarm occurs.			

Note: With no power connected to the unit, the alarm output will be in an open state.



Setting and Clearing Alarms

Configuration Menu

In
Input Type
C_F
Celsius/Fahrenheit
rL
Input Range Low
rH
Input Range High
0L1
Output 1 Function
0L2
Output 2 Function
rTS
Remote Timer Start
dISP
Display Default
ALTY ✓
Alarm Type
AHYS ✓
Alarm Hysteresis
LAE ✓
Alarm Latch
SIL ✓
Alarm Silencing
FAIL
Failure Mode

Operations Menu

AUT
Auto-tune
ALO ✓
Alarm Range Low
AHI ✓
Alarm Range High
PID
PID
CONF
Configuration

To Set Up Series 935B Alarms...

1. Plan an alarm strategy. What do you want to happen when an alarm occurs?
2. Wire the appropriate control output, Output 1 or Output 2, and associated switching and annunciators. See p. 44-45 for wiring information.
3. Go to the 935B's Configuration Menu [CONF]. See p. 18.
4. Set either Output 1 [0L1] or Output 2 [0L2] as the [ALTY] output.
5. Set Alarm Type [ALTY].
6. Set alarm hysteresis [AHYS].
7. Set alarm latching [LAE].
8. Set alarm silencing [SIL].
9. Set a failure mode [FAIL]. See p. 38-39.
10. Go to the 935B's Operation Menu. See p.12.
11. Set the alarm high and low [ALO] and [AHI] points.
12. Test and adjust the alarm system.
13. Document the alarm settings and system.

 **CAUTION:** Verify, in Table 10, p. 27, the alarm state / alarm output condition you want before making the Alarm Type [ALTY] choice. Failure to do so could result in damage to equipment and property.

 **WARNING:** Do not rely on the Series 935B alarms to provide redundant temperature limit control. Use correctly specified, properly installed temperature limit controls instead. Failure to do so could result in injury, death or damage to equipment and property. (See accompanying Watlow Bulletin 89.4.3.)









To Clear a Series 935B Alarm...

In general, press the [SET] key to clear a latched or 'silence-able' ([SIL] = [YES]) alarm.

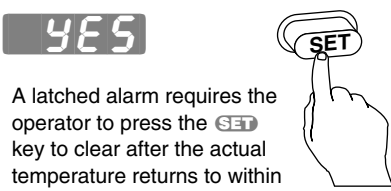
Ultimately, the system process value must return within the safe area for the alarm to remain clear. Non-latching alarms self-clear.

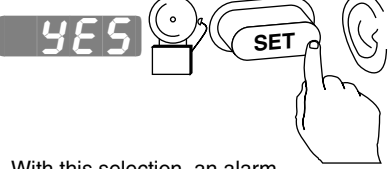
Table 11 (below) and Table 10 (p. 27) illustrate the Series 935B alarm features.

Table 11 - Alarm Functions

 <p>Latching alarm</p>	 <p>An unlatched alarm self-clears when actual temperature returns to within the safe area.</p>	 <p>A latched alarm requires the operator to press the SET key to clear after the actual temperature returns to within the safe area.</p>
 <p>Silence alarm</p>	 <p>With this selection, an alarm cannot be silenced at the 935B front panel (unless the alarm is latched [LAL=YES], and the alarm condition no longer exists).</p>	 <p>With this selection, an alarm can be silenced by pressing the SET key. YES provides automatic alarm silencing on start up.</p>
 <p>Alarm Low</p>	<p>A value from input Range Low to RhI.</p> <p>At the Range Low value, a  press displays oFF and RhI disables.</p>	
 <p>Alarm High</p>	<p>A value from ALo to input Range High</p> <p>At the Range High value, a  press displays oFF and RhI disables.</p>	

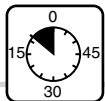

Learn the Countdown Timer

Configuration Menu

IN
Input Type

C_F
Celsius/Fahrenheit

rL
Input Range Low

rH
Input Range High

0t1
Output 1 Function

0t2 ✓
Output 2 Function

rTS ✓
Remote Timer Start

dISP ✓
Display Default

ALty
Alarm Type

AhYS
Alarm Hysteresis

•
•
•

tIPt ✓
Timer Function

Stert ✓
Start Timer

rdy ✓
Timer Ready Band

St ✓
Signal Time

Operations Menu

Aut
Auto-tune

tPTr ✓
Countdown Timer

IdLE ✓
Idle

Key Timer Information

- The timer requires Output 1 to work as either a heat or as a cool output.
- The 935B timer is a function of Output 2, a switched dc output.
- Hours: minutes (hh:mm) or minutes:seconds (mm:ss) choices reside in Output 2 **0t2**.
- Timer set-up occurs in two locations, in the Configuration Menu and the Operations Menu.
- **St** starts the timer.
- **Stert** stops the timer.
- **dISP** choices set up the timer display (see p. 18).
- LED colon flashes when timer runs. LED colon ON steadily when timer is not running.

Configuration Menu set-up includes: (see p. 18)

- Output 1 **0t1**; heat **HEAT** or cool **COOL**
- Output 2 **0t2**; timing interval, hours:minutes **tIPt**, or minutes:seconds **tP7S**
- Remote Timer Start **rTS** choices:
 1. Manual start **oFF**
 2. Remote Timer Start **tPTr**
 3. Front Panel Lockout **FPL**
- Timer (Output 2) function **tIPt** hours: minutes or minutes:seconds (**tIPt** or **tP7S**) can perform one of four possible actions after timing:
 1. Turn ON, also called, “delay ON” **dLoN**
 2. Turn off, also called, “delay off” **dLoF**
 3. Toggle ON, also called, “signal ON” **S9oN**
 4. Toggle off, also called, “signal off” **S9oF**
- Start timer function **Stert** choices:
 1. Immediate start **tP7d**
 2. Start once inside a ready band **rdy**
 3. Start once inside a ready band, acknowledging **rdyR** with a **SET** press
 4. Start immediately on control power up **PbUr** without waiting for Ready Band temp. or **St** press.
- Ready band width **rdy** above and below set point: degrees
- Signal time **St** (if applicable) duration: seconds

Operations Menu set-up includes: (see p. 12)

- Countdown Time **tP7r**: hours:minutes or minutes:seconds
- Idle Set Point Type **IdLE**, two choices:
 1. Track primary set point
 2. Set an idle set point

The next page presents this information in graphic format with additional detail.

Table 12 - Series 935B Timer Functions/Settings

	<p>Timer set-up available only when rtS=tPPr FPL oFF</p> <p>Choose time in hr:min or min:sec.</p>			
<p>Output 2 Timer Output Function; Choose one of four possible output actions for the end of the timer tPPr/St time periods.</p>	<p>Delay ON</p>	<p>Delay OFF</p>	<p>Signal ON</p>	<p>Signal OFF</p>
<p>Start Timer Function</p>	<p>1PPr Timer starts immediately on a key press at the normal display.</p> <p>rdY Timer only runs in the Ready Band. key starts timer sequence.</p> <p>rdYR Ready Acknowledge. key starts timer sequence. SET must be pressed once inside the Ready Band to start timer at the normal display.</p> <p>PuDr Timer starts immediately on control Power up. See p.57.</p>			
<p>Remote Start Timer</p>	<p>oFF No remote timer start or front panel lock feature.</p> <p>FPL Front panel lock with a customer-supplied switch on Terminals 3 and 4; a closed switch=locked front panel.</p> <p>tPPr Start timer via an external, customer-supplied switch on Terminals 3 and 4 closed switch=start.</p>			
<p>Timer Ready Band</p>	<p>RDY RDY</p> <ul style="list-style-type: none"> rdY = 0, Disables Ready feature The RDY front panel LED is lit inside Ready Band 			
<p>Signal Time</p>	<p>Sets the signal time from 00:01 to 99:59 min:sec to run after Timer.</p>			
<p>Operations Menu</p>				
	<p>0000 Timer Function OFF.</p> <p>9959</p> <ul style="list-style-type: none"> When 0t2 = tPPr or tPPrS, a 3 second SET press will display the rdLE set point. 			
<p>Idle Set Point</p>	<ul style="list-style-type: none"> Idle is set point used when not timing. If Trac selected Idle is the same as Set Point. The Set Point value controls the process during the Timer sequence. 			

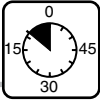

Setting the Countdown Timer

Configuration Menu

- ln**
Input Type

- C_F**
Celsius/Fahrenheit

- rl**
Input Range Low

- rh**
Input Range High

- 0t1**
Output 1 Function

- 0t2** ✓
Output 2 Function

- rt5** ✓
Remote Timer Start

- d1SP** ✓
Display Default

- ALty**
Alarm Type

- AhYS**
Alarm Hysteresis

-

- t1T7** ✓
Timer Function

- Strt** ✓
Start Timer

- rdy** ✓
Timer Ready Band

- St** ✓
Signal Time

- Operations Menu**

- Aut**
Auto-tune

- t1T7** ✓
Countdown Timer

- ldLE** ✓
Idle

To Set Up the 935B Timer...

1. Plan a timer strategy.
2. Wire the Output 2 control output, associated switching devices and annunciators. See p. 44-45.
3. Go to the 935B's Configuration Menu **[CF9]**.
4. Choose the Output 2 **0t2** function as time; hrs:min **t1T7**, or time; min:sec **t1T5**.
5. Choose Remote Timer Start **rt5** to function as; manual **oFF**, or remote timer start **t1T7r**.
6. Choose a display default **d1SP** (see page 18):
 - Actual Temperature only **Ac**
 - Actual; Set Point **AcSP**
 - Actual; Time **Actt**
 - Time; Actual **t1Ac**
 - Time; Set Point **t1SP**
7. Choose a Timer Output Function **t1T7**:
 - Delay ON **dLoN**
 - Delay off **dLoF**
 - Signal ON **S9oN**
 - Signal off **S9oF**
8. Choose a start timer **Strt** function; either immediate **1T7d**, ready band **rdy**, Ready Acknowledge **rdyA**, or Power **PLUr**.
9. If you chose **rdy** or **rdyA**, then select a ready band **rdy** value.
10. If you chose **S9oN** or **S9oF**, then select a signal time **St** value.
11. Go to the 935B's Operation Menu.
12. Set the countdown time **t1T7r**.
13. Choose the idle set point **ldLE** to track **t1Ac** the primary set point, or select a separate idle set point value between the range high **rh** and range low **rl** values.
14. Run the system, and test the timer start with a **[M]** press or **rt5** signal.
15. Document the timer settings and system.



Timer Example Application

Convection Oven Application

Scenario

A master chef bakes bread at 350°F for 30 minutes. He wants the oven at the proper temperature with an indication when it is ready to begin baking. He isn't concerned if the oven is 10° cool at first. After he loads the oven, the chef wants to start the countdown time by pressing a key. When the baking time is complete, he wants a 10 second audible indication that the bread is done.

Recommended Control

A Series 935B-1CCX-000X control.

- Switched dc Output 1 wired to a dc input solid state relay (SSR) switches the heaters.
- Switched dc Output 2 wired to a DC SSR-T0 SSR-240-10A-DC1 or A External Mechanical Relay audible indicator provides “done” indication.

Configuration Menu Set-up

C_F	=	°F	°F
dISP	=	Act i	After a SET press, actual temperature appears for 15 seconds.
Out 1	=	HEAT	Heating output
Out 2	=	TIME	Time; minutes:seconds
RTS	=	OFF	RTS must be set to OFF in this application
TEMP	=	59on	Output 2 turns ON briefly at the end of the timing cycle.
StRT	=	rdyR	Timer waits to countdown until temperature deviation from set point < rdy value and the SET key is pressed.
rdy	=	10	Ready band; 10°F
St	=	10	Output 2 turns ON for 10 sec. at the end of the timing cycle.

Operations Menu Set-up

TIME	=	3000	Bake time; 30 minutes
idle	=	75	The set point temperature before a timing cycle starts and after a timing cycle completes.

Set Point = **350**°F

Operator/Control Actions

- With the oven "idling" at 75°F, the chef starts the preheat cycle with a **PRE** press. The display immediately shows 30:00 with the colon ON steadily. The RDY LED is off. Series 935B begins to control to the 350°F bake set point.
- As the actual oven temperature increases to within the Ready Band at 350°F ±10°F, the RDY LED turns on. The chef loads the oven and presses **SET** to acknowledge the Ready Band and thereby start the bake cycle.
- Time starts counting down. Actual temperature displays for 15 seconds after the **SET** key is press. Then time displays with the colon flashing.
- If temperature deviates out of the Ready Band (less than 340°F or more than 360°F), timer countdown will pause, but will continue as soon as temperature re-enters the ready band.
- When time reaches 00:00, Output 2 turns on for 10 seconds sounding the audible indicator. The chef can stop the audible indicator by pressing **STOP**. The Series 935B then automatically shifts to the 75°F idle set point.



Auto-tuning

Operations Menu

AUT ✓

Auto-tune

AL0

Alarm Range Low

AL1

Alarm Range High

CT7r

Countdown Timer

IDLE

Idle

L-r

Local / Remote

PID

PID

CFG

Configuration

NOTE:

AUT is not visible at factory default.



CAUTION:

Successful Series 935B auto-tuning requires 3 oscillations thru the 90% set point in 85 min. or less. If the system cannot perform the oscillations in that time, the control will revert to the previous PID values.

NOTE:

Manual tuning is a slow procedure, taking from minutes to hours to obtain optimum value.

Auto-tuning the Series 935B

Auto-tune automatically sets PID parameters for your system.

1. Press **←** and **→** for three seconds.
2. You'll see **AUT**.
3. Press and hold **SET**, then select **YES** with **←** or **→**. **TUNE** will flash to indicate auto-tuning. Display reverts to normal after auto-tuning.
4. **AUT = NO** stops auto-tuning.

Figure 7 - Auto-tuning the Series 935B

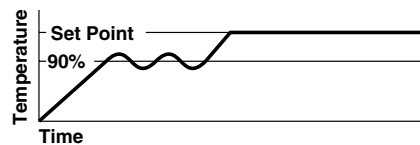

Auto-tuning occurs at 90% of set point in less than or equal to 85 minutes



Manual Tuning

For optimum performance, tune the Series 935B to your thermal system. The settings here are for a broad spectrum of applications; your system may have different requirements.

Tune heating outputs at a set point above ambient temperature.
Tune cooling outputs at a set point below ambient temp.

1. Apply power to the 935B and enter a set point.
In the Operations Menu, **AUT** must = **NO**.
Begin with these Configuration Menu settings:
Pb h = **1**, **It** = **000**, **dE** = **000**,
Ct h = **50**, **CRl** = **0**.
2. Proportional Band Adjustment: Gradually increase **Pb h** until the upper display temp. stabilizes at a constant value.
3. Integral Adjustment: Gradually decrease **It** from 30.00 until the display temperature begins to oscillate or "hunt." Then slowly increase **It** until the upper display stabilizes again near set point.
4. Cycle Time Adjustment: Set **Ct h** as required. Faster cycle times sometimes achieve the best system control. However, if a mechanical contactor or solenoid is switching power to the load, a longer cycle time will minimize wear on relays.
5. Derivative Adjustment: Increase **dE** to 0.10 minute. Then raise set point by 20° to 30°F, or 11° to 17°C. Observe approach to set point. If load temperature overshoots, increase **dE** by 0.50 minute. Raise set point by 20 to 30°F, or 11 to 17°C and watch approach again. Repeat until system rises to new set point appropriately.
6. Calibration Offset Adjustment: Enter the **CRl** offset value you want. Calibration offset adds or subtracts degrees from the value of the input signal.



Tweaking PID Settings

PID Menu

Set up Heat:

Pb h ✓
Proportional Band

HYSH ✓
Hysteresis

CT h ✓
Cycle Time

db ✓
Dead Band

Set up Cool:

Pb c ✓
Proportional Band

HYSc ✓
Hysteresis

CT c ✓
Cycle Time

Set up General:

IT ✓
Integral

dE ✓
Derivative

CAL ✓
Calibration Offset

1. Set **Pb h** and **CT h** in degrees.
2. If Proportional Band Heat **Pb h** = 0, Set Hysteresis Heat **HYSH**. The Series 935B will provide on/off control with the hysteresis value selected, and no proportioning action.
3. Proportional Bands should be decreased for tighter control but increased to eliminate oscillations.
4. Cycle Time Heat **CT h** is limited to a minimum of 5.0 seconds for the electromechanical relay to help reduce wear. The electromechanical relay (D, Output 2) is not recommended for PID control. It is warranted to 100,000 contact closures only. Alarm or on/off control are appropriate applications for the Series 935B's electromechanical relay output.
5. Set Dead Band **db** to adjust the effective cool set point above the primary set point by the dead band value in degrees. In cool/heat applications, dead band prevents continuous cool output action by creating a buffer between heating and cooling output action.
6. Set **Pb c** and **CT c** in degrees.
7. If Proportional Band Cool **Pb c** = 0, Set Hysteresis Heat **HYSc**. The Series 935B will provide on/off control with the hysteresis value selected, and no proportioning action.
8. Proportional Bands should be decreased for tighter control but increased to eliminate oscillations.
9. Cycle Time Heat **CT c** is limited to a minimum of 5.0 seconds for the electromechanical relay to help reduce wear. The electromechanical relay (D, Output 2) is not recommended for PID control. It is warranted to 100,000 contact closures only. Alarm or on/off control are appropriate applications for the Series 935B's electromechanical relay output.
10. Set Integral **IT** to eliminate droop in the system. Lower the value for more droop reduction. Adjustable from 0 to 99.9 minutes / repeat.
11. Set Derivative **dE** to prevent overshoot. Increasing the value slows the approach to set point. Adjustable from 0 to 9.99 minutes.
12. Calibration Offset **CAL** eliminates the difference between the displayed process temperature and the actual process temperature value.



Calibrating the 935B

Calibration Menu

tc50 ✓
tc50

tc00 ✓
tc00

tc ✓
tc

r15 ✓
r15

r380 ✓
r380

rst ✓
rst

Quick Calibration Restore:

Press all three keys simultaneously until **tc50** appears in the display, press **↵** once and **rst** will appear in the display. Press and hold **SET**, the display will show **no**, press **↵** to change display to **YES**. Press and hold **↵** and **↵** for 3 seconds to exit the **CAL** menu.

NOTE: Restore Factory Calibration
rst = YES
restores factory calibration values to all calibration prompts.

Calibration Key Information

Calibration requires a precision millivolt source with thermocouple compensation, an adjustable 0-10 volt source, and a decade resistance box.

- **tc50** and **tc00** calibrate the thermocouple span.
- **tc** calibrates the ambient compensation.
- **r380** and **r15** calibrate the RTD span.
- When calibrating, calibrate all points for consistency in results.
- Allow the unit to warm up for 15 minutes before calibrating.

Figure 8a - Thermocouple Calibration

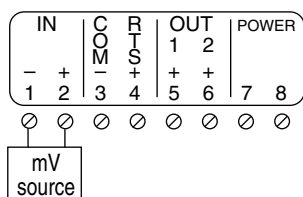

tc50
mV source = 50.000mV

- Store TC counts at 50.000mV

tc00
mV source = 0.000mV

- Store TC counts at 0.000mV

tc
mV source = Temp. Compensation

- Store ambient counts at 32° F. Type J.

Figure 8b - RTD Calibration

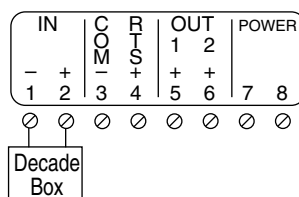

r15
Decade Box = 15.00 ohms

- Store low end RTD counts

r380
mV source = 380.00 ohms

- Store high end RTD counts

rst **no**
YES
• Restore factory calibration

Calibrating the 935B

Thermocouple Input Field Calibration Procedure

Equipment Required:

- Type “J” Reference Compensator with reference junction at 32°F/0°C, or Type “J” Thermocouple Calibrator set at 32°F/0°C.
- Precision millivolt source, 0-50mV min. range, 0.01mV resolution.

Set Up:

1. Connect 100-240V~ (ac) to Terminal 7 and Terminal 8.
2. Connect the millivolt source to Terminal 1 negative and Terminal 2 positive.
3. Apply power to the unit and allow it to warm up for 15 minutes.

Move to the Calibration Menu:

1. Press and simultaneously for 3 seconds.
2. Press or until **LnFg** is displayed.
Press and hold **SET** – press or to select **YES**, then release **SET**.
3. Press or until **LRg** is displayed.
Press and hold **SET**. Press or 8 times (display shall be blank).

Calibration: (Thermocouple)

1. Press and hold **SET**, , and simultaneously for 3 seconds until **LR50** is displayed.
2. Set the mV source to 50.00mV^{dc} (dc). Allow 10 seconds for sources to stabilize. Press and hold **SET**. Press or until **YES** appears. Release **SET**.
3. Press - **LR00** shall be displayed.
4. Set the mV source to 0.00 mV^{dc} (dc). Allow 10 seconds for sources to stabilize. Press and hold **SET**. Press or until **YES** appears. Release **SET**.
5. Press . **LR** shall be displayed.
6. Set the MV source to 0.00 mV (if using a temperature compensator). Set calibrator to 32°F/0°C.
Allow 10 seconds for sources to stabilize.
Press and hold **SET**. Press or until **YES** is displayed. Release **SET**.

Calibration: (RTD)

Equipment Required:

- Precision Resistance Box with 0.01Ω Resolution.
1. Remove thermocouple wires from Terminal 1 and Terminal 2.
 2. Connect S2 to terminal 1. Connect S1 to Terminal 2.
 3. Press . **r 15** shall be displayed.
 4. Set the Decade box to 15.00Ω (allow 10 seconds for sources to stabilize). Press and hold **SET**. Press or until **YES** appears. Release **SET**.
 5. Press - **r 380** shall be displayed.
 6. Set the decade box to 380.00Ω (allow 10 seconds for sources to stabilize). Press and hold **SET**. Press or until **YES** appears. Release **SET**.
 7. Press and hold and for 3 seconds to Exit calibration menu.

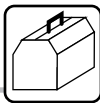

Errors and Troubleshooting

Configuration Menu

in	Input Type
C_F	Celsius/Fahrenheit
rL	Input Range Low
rH	Input Range High
0t1	Output 1 Function
0t2	Output 2 Function
dISP	Display Default
ALTY	Alarm Type
ALYS	Alarm Hysteresis
LAL	Alarm Latch
SIL	Alarm Silencing
FAIL	Failure Mode
t1P7	Timer Function
StRT	Start Timer
rdY	Timer Ready Band
St	Signal Time
SLOC	Set Point Lockout
tA9	Lockout Tag

Key Error Information

Set up an input failure operation mode at the **FAIL** prompt in the **CONF9** menu; choose bumpless transfer **bPLS** for smooth output action transition to percent power control, or select a percent power output value.

FAIL **bPLS**

Bumpless Transfer

when errors occur, the control output will continue at a percent output learned while stable. Default = **bPLS**.

-100 **100**

Percent Power







(-100% to +100% , depending on heat/cool output configuration). The control will assume a specific output power when input errors occur.

- All except one of the possible displayed error messages are input related.
- If you see **ERS**, cycle power to the controller. If the error persists, call the factory.
- Be aware of the difference between U.S and European thermocouple color/colour codes.
- Reversed polarity input leads is one of the most common errors.
- Incorrect software input choice at the Configuration Menu **CONF9** input **in** prompt is another common error.

When calling the factory for help, please have:

1. The model number of the control.
2. A photocopy of pages 51-58 with the settings from your control, if possible.
3. Specifications of devices directly interfaced with the control.

Table 13 - Possible Displayed Error Codes and Actions

Display	Probable Cause	Recommended Action	
	Reversed thermocouple connection + to -.	Change the sensor leads on Terminals 1 and 2.	A-D under flow
	Sensor type mismatch or open RTD.	Go to In prompt, check selection (see p. 22), or check RTD, replace as necessary.	Sensor under range
	Sensor type mismatch.	Go to In prompt, check selection (see p. 22).	Sensor over range
	Open Thermocouple, bad	Check the sensor, connection, or broken wire.	A-D replace as necessary.
	Electrical noise.	Cycle power to system. See if error clears. Check system for electrical interference.	
	Control is inoperable.	Check for line voltage at terminals 7 and 8.	

To Troubleshoot Sensor

- Remove sensor wires from Terminals 1 and 2.
- For a thermocouple sensor Series 935B, place a jumper wire on Terminals 1 and 2. Control should display the ambient temperature at the back of the control.
- For an RTD sensor Series 935B, place a 110 +/- 10Ω resistor on Terminals 1 and 2. The control should read 100Ω = 32°F, 110Ω = 77°F, 120Ω = 127°F.
- An RTD sensor Series 935B can be configured in software as if it were a thermocouple unit, and then tested as above.
- You can restore factory calibration , see p. 36-37.

Table 14 - Troubleshoot Control Outputs

When indications such as significant differences between set point and actual temperatures point to no output action, check output configurations as described on p. 23. Check wiring, p. 44.

Output	Measure Terminals	Load-on State	Load-off State
"C" Output 1	3 & 4	LED 1 on 3.0 to 7.0V _{DC} (dc)	LED 1 off 0.0V _{DC} (dc)
"C" Output 2	5 & 6	LED 2 on 3.0 to 7.0V _{DC} (dc)	LED 2 off 0.0V _{DC} (dc)

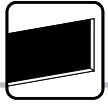

Mounting

Figure 9- Panel Cut-out Dimensions

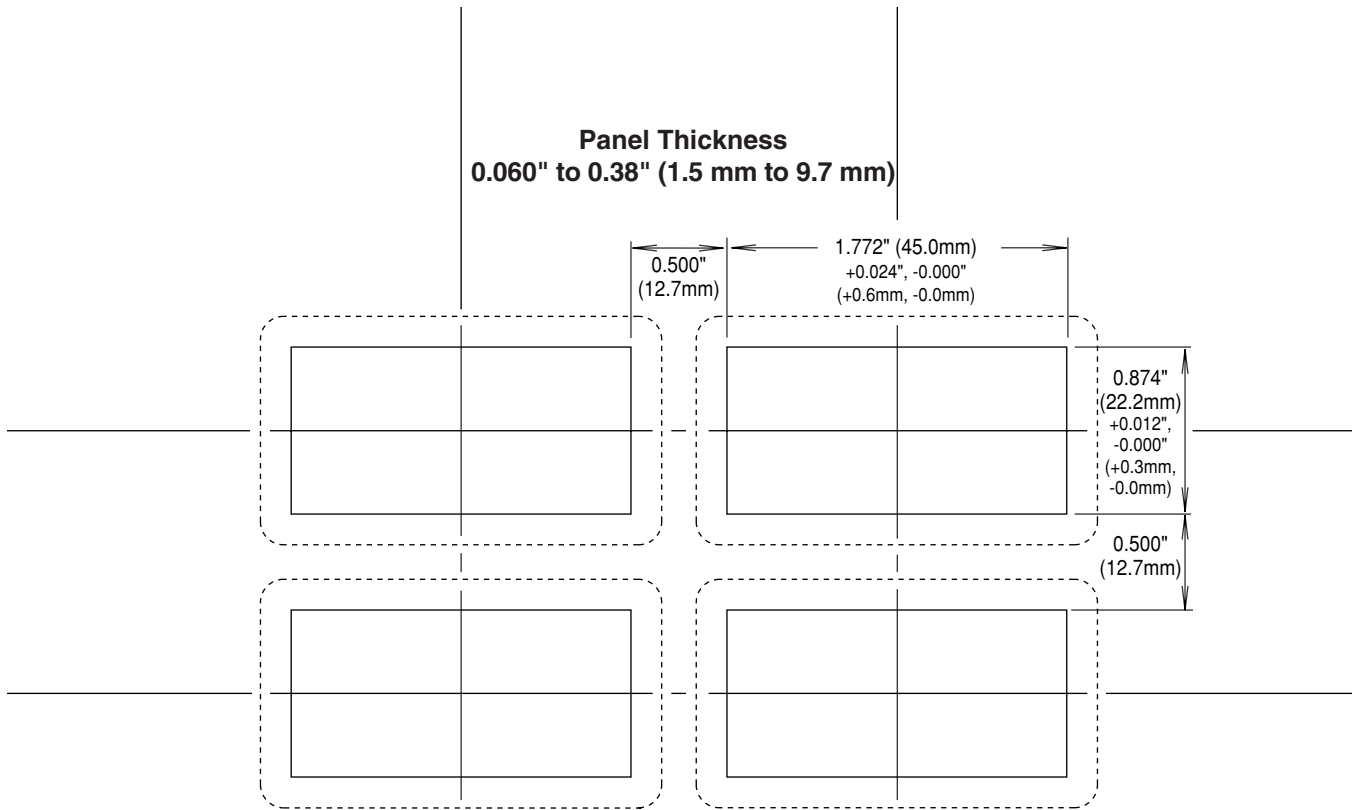
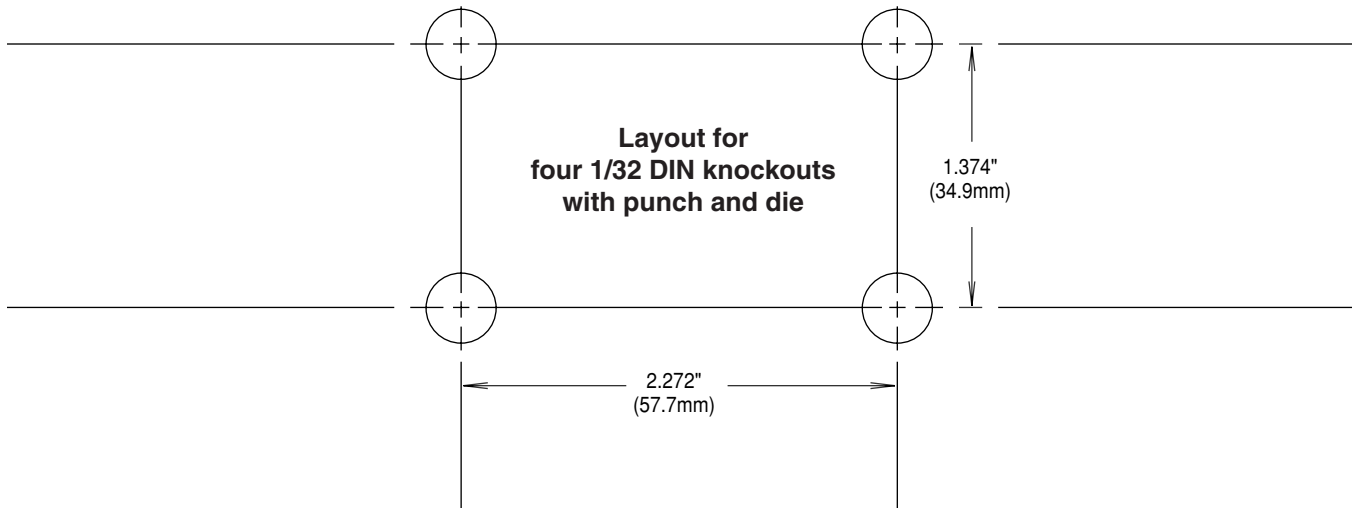

Figure 10- Mounting Layout for Knockouts



Greenlee Textron, Inc., Phone: 1-800-435-0786.
Catalog Number: 50740180; Available: 4-6 weeks, Greenlee distributor.



Dimensions

Figure 11- Series 935B Dimensions

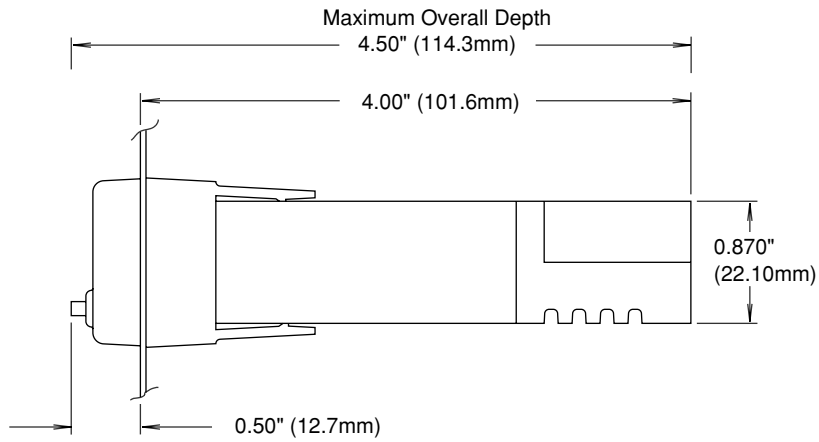
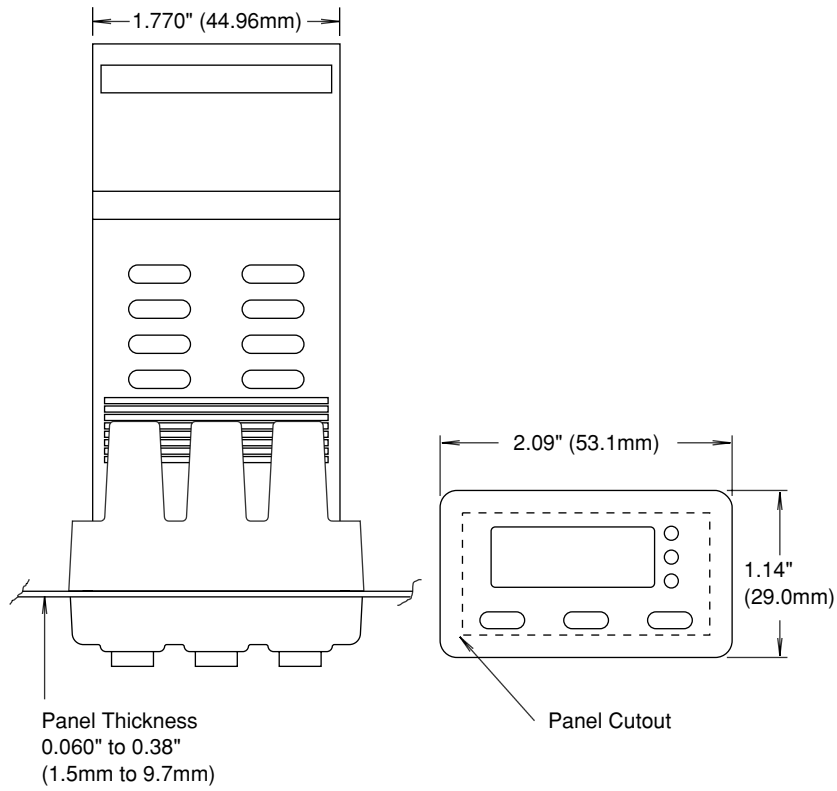

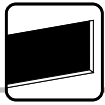

Installing the Series 935B

Installation Procedure

1. Make a panel cutout using the tear-out mounting template, or the dimensions in Figure 9, p. 40.
2. Insert the 935B into the cutout. Check to see that the gasket is not twisted. Make sure the rounded side of the D-shaped external case gasket faces the panel surface, and the gasket is fully seated in its bezel channel. See Figure 12.
3. While pressing the bezel firmly against the panel, slide the mounting collar over the back of the control. The tabs on the collar must line up with the mounting ridges on the case for secure installation. See Figure 12 again.
4. Slide the collar firmly against the back of the panel, getting it as tight as possible. Make sure you cannot move the case within the cutout, if you can, you do not have a NEMA 4X/IP65 seal!
5. Make sure you have a tight seal. Use your thumb to lock the tabs into place while pressing the case from side to side. Don't be afraid to apply enough pressure to install the control. The tabs on each side of the collar have teeth which latch into the ridges. See Figure 12. Each tooth is staggered at a different depth (from the front) so only one of the tabs on each side is ever locked into the ridges at any time.
6. Look at Figure 13; you see that the tabs on one side of the collar correspond with those on the opposite side. Be sure only the two corresponding tabs are locked in the ridges at the same time. If the matching tabs are not holding the case, no NEMA 4X/IP65 seal exists. Make a visual check, or use your finger nail to pull out on each tab. The space between the bezel and panel must be 0 to 0.019" (0.48 mm).

Figure 12- Mounting, Case Top View and Collar Cross Section.

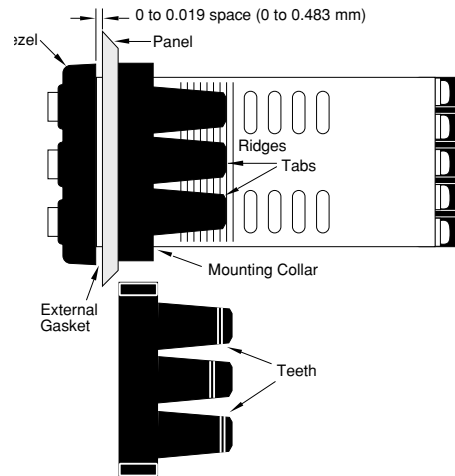
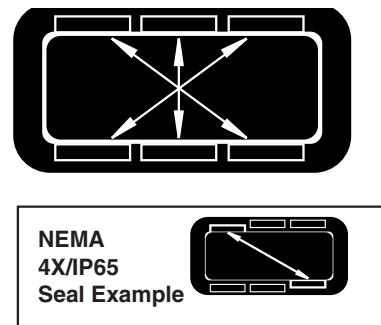

Figure 13- Case Rear View and NEMA 4X/IP65 Seal Example



Collar Removal

To remove the mounting collar:

Slide a thin, wide tool (putty knife) under all three mounting tabs, top then bottom, while pushing forward on the back of the case.

NOTE: To guarantee a proper NEMA 4X / IP65 seal, make sure the gasket between the panel and the rim of the case is not twisted and is seated properly. Press firmly.

NOTE: Make sure the rounded side of the D-shaped external case gasket faces the panel surface, and the gasket is fully seated in its bezel channel. See Figure 12.



Terminal Block Removal

Figure 14- Terminal Block Removal Procedure

1. Press in on sides of cover to release the terminal cover hooks.

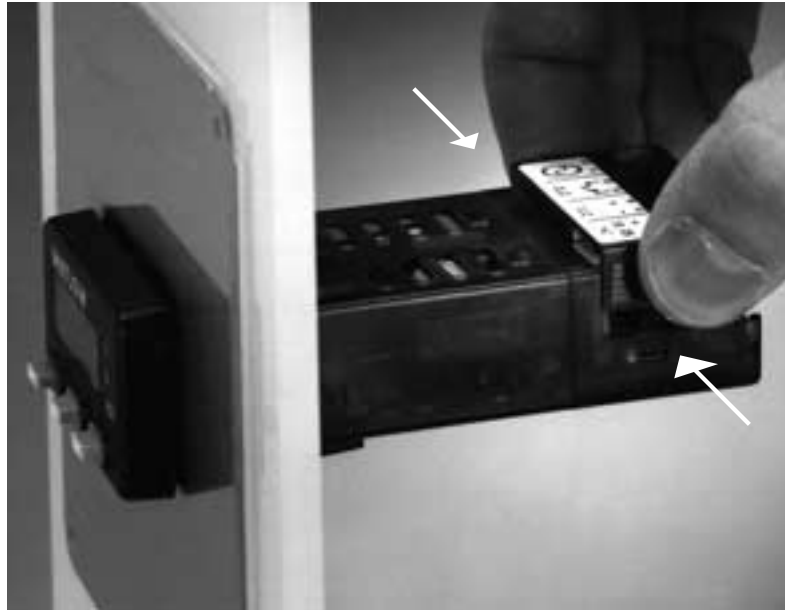

2. Move your grip rearward slightly, then lift the terminal cover straight up.

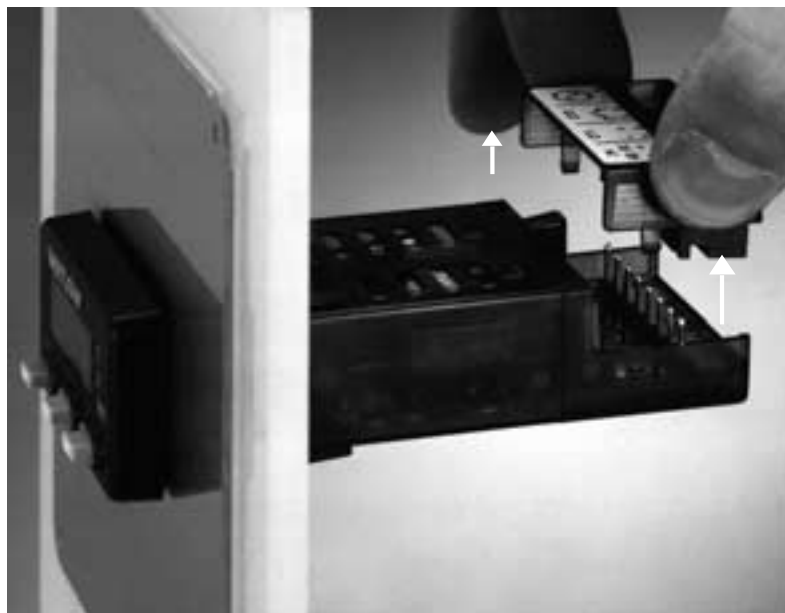



Wiring a 935B

Figure 15 - Wiring the Series 935B



WARNING: All wiring and fusing must conform to local and national electric codes. Contact local authorities for further information. Failure to comply with electric codes could result in injury or death, or damage to property.

Power Wiring

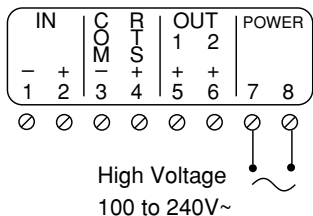

Remote Timer Start

(Closed switch = Starts Timer)

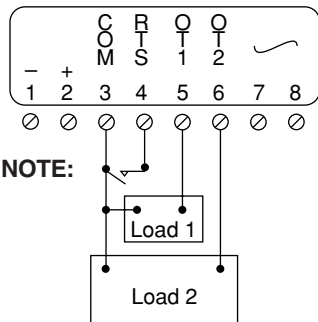

Front Panel Lock

(Closed switch = locked panel)

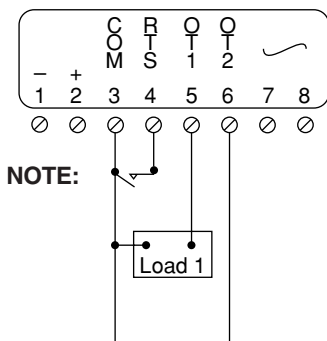

Input Wiring

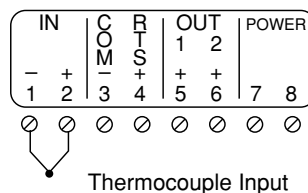
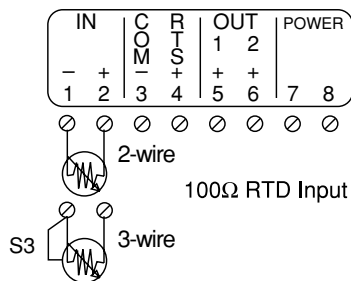

CAUTION: Using grounded thermocouples with non-isolated output switching devices could introduce ground loops into the control system, and possibly damage the controller and product.

Output 1 Wiring

Internal Circuitry

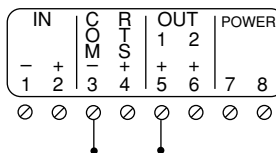
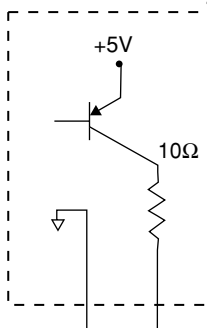

Output 1; Switched DC; "C"

Output 2 Wiring

Internal Circuitry

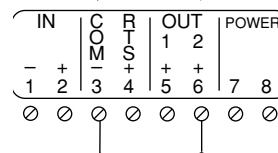
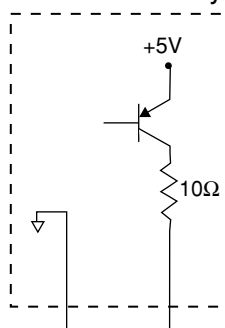

Output 2; Switched DC; "C"

NOTE: Both Output 1 and Output 2 are DIN-a-mite® compatible.



System Wiring Examples



WARNING: All electrical wiring and fusing must conform to local and national electric codes. Contact local authorities for further information. Failure to comply with electric codes could result in injury or death, or damage to property.

Figure 16 - Series 935B System Wiring Examples

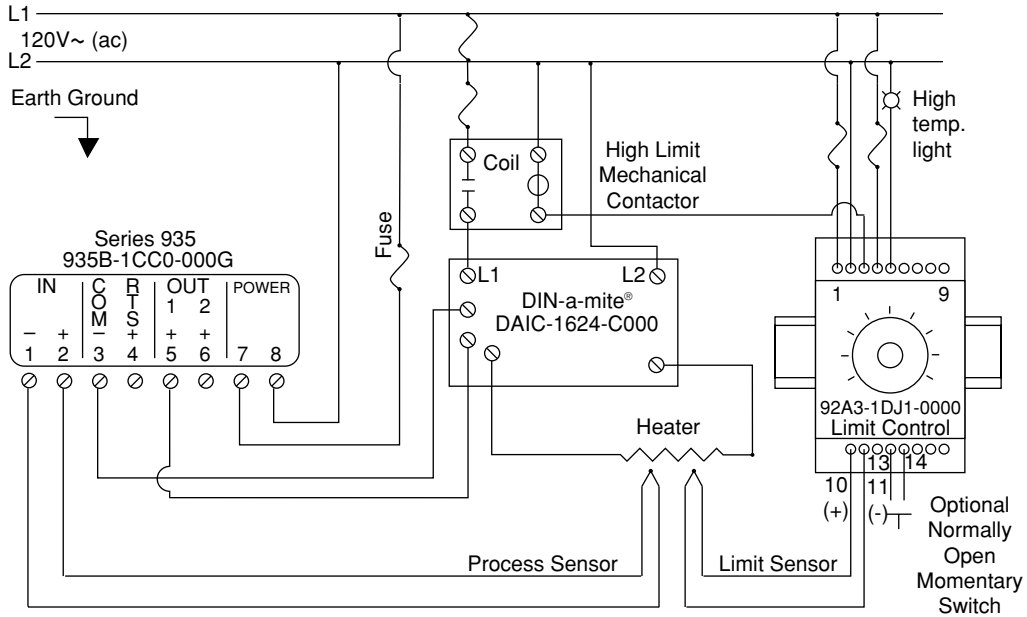

CAUTION: Using grounded thermocouples with non-isolated output switching devices could introduce ground loops into the control system, and possibly damage the grounder and product.

Figure 17 - Series 935B Ladder Diagram Wiring Example

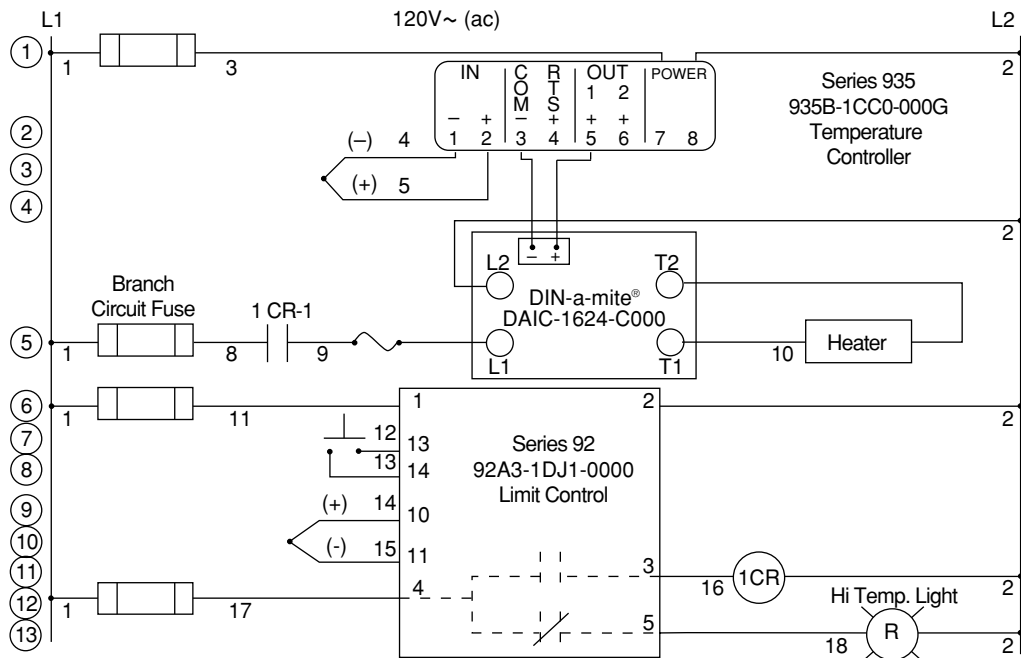



Glossary

- Alarm**
A condition, generated by the controller, indicating that the process has exceeded or fallen below the set or limit point.
- Alarm Hysteresis**
A change in the process variable required to re-energize the alarm output.
- Ambient Temperature**
Temperature surrounding the components of a thermal system.
- Auto-tune**
Automatically sets PID values to fit a particular thermal system.
- Bumpless Transfer**
When transferring from auto to manual operation, the control output(s) will maintain the same output level.
- Calibration**
Adjusting an instrument to a known value.
- Configuration Menu** -The second software sub menu of the Series 935B Operations Menu; provides a location to set inputs, ranges, output types, alarm type, timer function, failure mode, and lockout types.
- Control Mode**
The method of control, i.e. ON/OFF, time proportioning, PI, PID or manual.
- Cycle Time**
Time required for a control to complete one ON through OFF cycle.
- Dead Band**
Adjusts the effective cool set point above the primary set point by the dead band value in degrees. In cool/heat applications, dead band prevents continuous cool output action by creating a buffer between heating and cooling output action.
- Delay OFF**
A Series 935B timer output (Output 2) choice that turns the output OFF at the end of the countdown timer time.
- Delay ON**
A Series 935B timer output (Output 2) choice that turns the output ON at the end of the countdown timer time.
- Derivative**
Limits the rate of change of the process to eliminate overshoot in slow or lagging loads ($de=ra$).
- Deviation Alarm**
An offset value which tracks the set point. Process changes beyond this value register an alarm condition.
- DIN-a-mite®**
Watlow family of DIN rail-mounted SCR power controllers.
- Droop**
The difference between the set point and actual values once the system stabilizes.
- Hysteresis**
A change in the process variable required to re-energize the control or alarm output.
- Idle Set Point**
Desired control value before and after timing period.
- Integral**
Accumulates error to eliminate offset or droop ($It=1/re$).
- Local Set Point**
Primary set point, not remote.
- ON/OFF**
Control by turning the output full ON until set point is reached, and then turning OFF until the process error exceeds the hysteresis.
- Operations Menu**
Series 935B software menu; provides a location to start auto-tune, set alarm points, set countdown time, choose an idle or normal set point type, choose a local or remote set point input, and to go to the PID or Configuration Menus.
- Overshoot**
The amount a process variable exceeds set point before stabilizing.
- Percent Power Control**
Open loop control with output power set at a particular level.
- PID**
(Proportional, Integral, Derivative). A control mode: proportional action sets the system, integral reduces droop, derivative reduces overshoot and undershoot.
- PID Menu**
The first software sub menu of the Series 935B Operations Menu; provides a location to manually set values for proportional band, hysteresis, cycle time, integral, derivative, and calibration offset.
- Process Alarm**
A fixed value independent of set point. Process changes beyond this value register an alarm condition.
- Process Error**
The difference between the set point and the actual process.
- Proportional**
Output effort proportional to the error from set point. If the proportional band is 20° and the process is 10° below set point, the heat proportioned effort is 50%. The lower the Pb value, the higher the gain.
- Proportional Band**
A range in which a control's proportioning function is active (See PID).
- Range**
The area between two limits in which a quantity or value is measured. Usually expressed in terms of lower and upper limits.
- Ready Acknowledge**
A Series 935B countdown timer start choice that pre-initiates the timer with a down key press, and then starts it with a SET press when the actual temperature is within the Ready Band.
- Ready Band**
Thermal area above and below primary set point in which the timer will count down.
- Relay, Electromechanical**
A power switching device that completes or interrupts a circuit by physically moving electrical contacts. Not recommended for PID control.
- RTD**
Resistive Temperature Detector. A sensor whose resistance increases with increasing temperature.
- Remote Timer Start**
Activation of the timer functions using an external remotely mounted switch connected to the 935B RTS input.
- Set Point**
The desired process value programmed into a control.
- Signal**
Any electrical transmittance that conveys information.
- Signal OFF**
A Series 935B timer output (Output 2) choice that toggles the output OFF, then ON at the end of the countdown timer cycle for a period equal to the signal time.
- Signal ON**
A Series 935B timer output (Output 2) choice that toggles the output ON, then OFF at the end of the countdown timer cycle for a period equal to the signal time.
- Signal Time**
Time duration the timer output will turn ON or OFF after a complete timing period.
- SCR**
Silicon controlled rectifier. A solid state device, or thyristor, with no moving parts, that is used in pairs to control AC voltages within one cycle. SCRs control voltage from a power source to the load by burst firing (also called zero-cross firing) or phase angle firing.
- SSR**
Solid State Relay. A solid state switching device that switches current ON and OFF. It has no moving parts.
- Thermal System**
A regulated environment consisting of a heat source, heat transfer medium, sensing device, a control instrument, and a redundant control device (limit).
- Thermocouple**
A temperature sensing device made by joining two dissimilar metals. This junction produces an electrical voltage in proportion to the difference in temperature between the hot junction and lead wire connection to the sensing device (cold junction).
- Undershoot**
The amount a process variable falls below set point before stabilizing.



Index

A

Auto-tune **AUT** 12, 34
 Alarms
 Alarm High **AHI** 12, 26
 Alarm Low **ALO** 12, 26
 Alarm Type **ALTY** 26, 27
 Clearing 28, 29
 Deviation **dENC**, **dENO** 26, 27
 Hysteresis **AHYS** 26, 27
 Latch **LAL** 26, 29
 Learning 26
 Process **PRNC**, **PRNO** 26, 27
 Setting 28, 29
 Silencing **SIL** 26, 29

B

Bumpless Transfer **BPLS** 38

C

Calibration 36, 37
 Factory Restore **rSE** 36
 Calibration Offset **CAL** 15, 17
 Celsius / Fahrenheit **C_F** 22, 23
 Clearing Alarms 28, 29
 Configuration **CNF9** 11, 18
 Cycle Time 15
 Heat **Ct h** 15
 Cool **Ct c** 15

D

Dead Band **db** 15
 Derivative **dE** 15, 17
 Dimensions 40, 41
 DIN-a-mite® compatibility 44, 48
 Display Default **dISP** 18, 22

E

Errors 10, 39

F

Failure Mode **FAIL** 19, 38
 Front Panel Lock **FPL** 22, 25

G

Glossary 46

H

Hours/Minutes **hPp** 30-32
 Hysteresis
 Alarm **AHYS** 19, 26
 Heat **hYSh** 15
 Cool **hYSc** 15

I

Idle **IdLE** 12
 Idle Set Point Track **ISrAc** 12
 Input Range Low **rL** 22, 23
 Input Range High **rh** 22, 23
 Input Type **in** 23
 Integral **It** 15, 17

K

Keys 7

L

Latch **LAL** 19, 26, 29
 Lockout Functions 20
 Front Panel **FPL** 20, 25
 Security Tag **LAG** 20
 Set Point **SLOC** 20

M

Minutes/Seconds **MPs** 19, 30
 Mounting 40

O

Operations, Learning 12
 Ordering Information 49
 Output 1 Function **Out1** 5, 22, 23
 Output 2 Function **Out2** 5, 22, 23

P

PID Menu, Learning 14
 PID Settings, Tweaking 15, 35
 Proportional Band
 Heat **Pb h** 15
 Cool **Pb c** 15

R

Remote Timer Start **rTS** 22, 24

S

Set Point
 Change 9
 Lock **SLOC** 20
 Range High **rh** 22
 Range Low **rL** 22
 Silencing Alarms 29
 Software Maps
 Easy 11
 Advanced 51-58
 Specifications 48

T

Terminal Block Removal 43
 Timer
 Countdown **TPPr** 12, 30-33
 Delay off **dLoF** 19, 30, 31
 Delay on **dLoN** 19, 30, 31
 Function **TPPr** 19, 30, 31
 Hours/Minutes **hPp** 19, 30, 31
 Idle **IdLE** 19, 30, 31
 Minutes/Seconds **MPs** 19, 30, 31
 Ready Band **rDY** 19, 30, 31
 Signal off **SGoF** 19, 30, 31
 Signal on **SGoN** 19, 30, 31
 Signal Time **St** 19, 30, 31
 Start Timer **StTt** 19, 30, 31
 Immediate **IPrd** 19, 30, 31
 Ready Band **rDY** 19, 30, 31
 Ready Band-Acknowledge **rDYA** 19, 30, 31

Tuning
 Auto-tuning 12, 34
 Manual tuning 34, 35
 Troubleshooting 38, 39

W

Wiring 44
 Wiring Examples 45

- Height
- Length
- Width

Specifications

Specifications—(1951)

Control Mode

- Auto-tune PID.
- PID, PD, PI, on/off.
- Countdown timer; hours:minutes, minutes:seconds.
- Timer output modes; Delay-off, Delay-on, Signal-off, Signal-on.

Agency Approvals

- UL/C-UL 508, File #E102269.
- NEMA 4X₁ (IP65) rated front panel.
- 89/336/EEC Electromagnetic Compatibility Directive: EN 50081-2: 1994 Emissions; EN 50082-2: 1995 Immunity.
- 73/23/EEC Low-voltage Directive: EN 61010-1: 1993 Safety.

Operator Interface

- Single, seven-segment digital display, factory selectable red or green.
- Outputs/operation annunciators, three discrete LEDs.
- Three tactile feedback momentary switches.
- Front panel lock dry contact closure disables front panel operation.

Accuracy

- $\pm 0.25\%$ of span ± 1 LSD, or
- Types S and T thermocouple @ $< 200^\circ\text{C}$, $\pm 0.32\%$ of span ± 1 LSD, typical.

Ambient Rejection

- $< 0.15^\circ\text{C}/^\circ\text{C}$ rise in ambient, or
- Types S and T thermocouple, @ $< 0.47^\circ\text{C}/^\circ\text{C}$ rise in ambient typical.

Sensors/Inputs

- Sensor input sampling rate: 10 samples/second (10Hz).
- Type E, J, K, N, S and T thermocouple, grounded or ungrounded junction.
- RTD, two-wire 100Ω base (DIN) resistance.
- Dry contact closure on RTS input enables remote timer start function or front panel lock, depending on menu selection.

Input Range

Specified temperature ranges represent the controller's operational span.

Thermocouple

Type E	-328 to 1470°F
	(-200 to 799°C)
Type J	32 to 1382°F
	(0 to 750°C)
Type K	-328 to 2282°F
	(-200 to 1250°C)
Type N	32 to 2282°F
	(0 to 1250°C)
Type S	32 to 2642°F
	(0 to 1450°C)
Type T	-328 to 662°F
	(-200 to 350°C)

RTD Resolution (DIN)

1°	-328 to 1292°F
	(-200 to 700°C)
0.1°	-199.9 to 999.9°F
	(-128.8 to 537.7°C)

Control Output

- Output update rate: 1/second (1Hz).

1 Output

- Switched dc logic signal, $6\text{V}\hat{\text{I}}$ (dc) @ 60mA nominal, short circuit protected, non-isolated (Watlow *DIN-a-mite*® power controller compatible).

2 Output

- Switched dc logic signal, $6\text{V}\hat{\text{I}}$ (dc) @ 60mA nominal, short circuit protected, non-isolated (Watlow *DIN-a-mite*® power controller compatible).

Output Cycle Time

- Switched dc; 5.0 second default, 0.1 second minimum.

Line Voltage/Power

- 100-240V~ (ac) +10%, -15%; (85-264V~ [ac]) 50/60Hz, $\pm 5\%$.
- Fused internally (factory replaceable only) time-lag type, 2A, 250V.
- Power consumption 6VA maximum.
- Data retention upon power failure via non-volatile memory.

Operating Environment

- 32 to 149°F (0 to 65°C).
- 0 to 90% RH, non-condensing.

Storage Temperature

- -40 to 185°F (-40 to 85°C).

Terminals

- Touch-safe set screw type, accepts 22 to 12-gauge wire.

Controller Weight

- 4.0 oz (113.4 g).

Shipping Weight

- 7.3 oz (208 g).

These specifications are subject to change without prior notice.

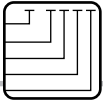

Ordering a 935B

Ordering Information—(1952)

Single thermocouple or RTD (DIN) input,
dual output, single display temperature
control with time function

9 3 5 B - 1 C C 0 - 0 0

Output 1/Remote Input

C = Switched dc, logic signal, non-isolated

Output 2

C = Switched dc, logic signal, non-isolated

Power Supply

0 = 100 to 240V~ (ac)

Custom Options

00 = None

AA-ZZ = Consult factory for options

Display

R=Red Displays

G=Green Displays

Table 15 - Input Range Information

J t/c:	32 to 1382°F	or	0 to 750°C
K t/c:	-328 to 2282°F	or	-200 to 1250°C
T t/c:	-328 to 662°F	or	-200 to 350°C
N t/c:	32 to 2282°F	or	0 to 1250°C
S t/c:	32 to 2642°F	or	0 to 1450°C
E t/c:	-328 to 1470°F	or	-200 to 799°C
1° RTD (DIN):	-328 to 1292°F	or	-200 to 700°C
0.1° RTD:	-99.9 to 999.9°F	or	-99.9 to 700.0°C

¹ To effect NEMA 4X (IP65) rating requires a minimum mounting panel thickness of 0.06 inch (1.5mm) and a surface finish not rougher than 0.000032 inch (0.000812 mm).



CE Compliant Product

Declaration of Conformity

Series 935



WATLOW CONTROLS

1241 Bundy Boulevard

Winona, Minnesota 55987 USA

Declares that the following product:

English

Designation: Series 935
 Model Number(s): 935A or B - 1C (C D or K) (0 or 1) - (Any four numbers or letters)
 Classification: Control, Installation Category II, Pollution Degree II
 Rated Voltage: 100 to 240V~ or 24 to 28V~
 Rated Frequency: 50/60 Hz
 Rated Power Consumption: 6VA maximum

Meets the essential requirements of the following European Union Directive(s) using the relevant section(s) of the normalized standards and related documents shown:

89/336/EEC Electromagnetic Compatibility Directive

EN 50082-2: 1995 EMC Generic immunity standard, Part 2: Industrial environment

EN 61000-4-2: 1995 Electrostatic discharge
 EN 61000-4-4: 1995 Electrical fast transients
 EN 61000-4-3: 1996 Radiated immunity
 EN 61000-4-6: 1996 Conducted immunity

ENV 50204: 1995 Cellular phone
EN 50081-2: 1994 EMC Generic emission standard, Part 2: Industrial environment

EN 55011: 1991 Limits and methods of measurement of radio disturbance characteristics of industrial, scientific and medical radio-frequency equipment (Group 1, Class A)

EN 61000-3-2: 1995 Limits for harmonic current emissions
EN 61000-3-3: 1995 Limitations of voltage fluctuations and flicker

73/23/EEC Low-Voltage Directive

EN 61010-1: 1993 Safety requirements for electrical equipment for measurement, control, and laboratory use, Part 1: General requirements

Déclare que les produits suivants :

Français

Désignation : Série 935
 Numéro de modèle : 935A or B - 1C (C D ou K) (0 ou 1) - (N'importe lesquels des quatre chiffres ou lettres)
 Classification : Réglage, installation de catégorie II, taux de pollution II
 Tension nominale : 100 à 240 V ~ ou 24 à 28 V ~
 Fréquence nominale : 50/60 Hz
 Consommation d'énergie nominale : 6 volt-ampères maximum

Sont conformes aux principales normes des directives de l'Union Européenne au regard de la (des) section(s) pertinente(s) des normes standards et documents apparentés présentés :

89/336/EEC Directive de compatibilité électromagnétique

EN 50082-2 : 1995 Norme générique immunité 2^e partie : Environnement industriel

EN 61000-4-2 : 1995 Décharge électrostatique
 EN 61000-4-4 : 1995 Transitoires rapides électriques
 EN 61000-4-3 : 1996 Immunité rayonnée
 EN 61000-4-6 : 1996 Immunité conduite
 ENV 50204 : 1995 Téléphone cellulaire

EN 50081-2 : 1994 Norme générique émission - 2^e partie
EN 55011 : 1991 Limites et méthodes de mesure des caractéristiques des perturbations radioélectriques des appareils industriels, scientifiques et médicaux (I.S.M.) à fréquence radioélectrique (Groupe 1, Catégorie A)

EN 61000-3-2 : 1995 Limites d'émission d'harmoniques
EN 61000-3-3 : 1995 Limitations d'écart de tension et de papillotement

73/23/EEC Directive de basse tension

EN 61010-1 : 1993 Normes de sécurité des équipements électriques de mesure, de contrôle et à usage laboratoire, section 1: normes générales

Erklärt, daß das folgende Produkt:

Deutsch

Beschreibung: Serien 935
 Modellnummern: 935A or B - 1C (C D oder K) (0 oder 1) - (4 beliegige Buchstaben)
 Klassifikation: Regelsystem, Installationskategorie II, Emissionsgrad II
 Nennspannung: 100 bis 240 V~ oder 24 bis 28 V~
 Nennfrequenz: 50/60 Hz
 Stromverbrauch: Max. 6 VA

Erfüllt die wichtigsten Normen der folgenden Anweisung der Europäischen Gemeinschaft unter Verwendung des wichtigen Abschnitts der normalisierten Spezifikationen und der untenstehenden einschlägigen Dokumente:

89/336/EEC Elektromagnetische Übereinstimmungsanweisung

EN 50082-2: 1995 EMC Rahmennorm für Störsicherheit, Teil 2: Industrielle Umwelt

EN 61000-4-2: 1995 Elektrostatische Entladung
 EN 61000-4-4: 1995 Elektrische schnelle Stöße
 EN 61000-4-3: 1996 Strahlungsimmunität
 EN 61000-4-6: 1996 Leitungsimmunität

ENV 50204: 1995 Mobiltelefon
EN 50081-2: 1994 EMC-Rahmennorm für Emissionen, Teil 2: Industrielle Umgebung

EN 55011: 1991 Beschränkungen und Methoden der Messung von Funkstörungsmerkmalen industrieller, wissenschaftlicher und medizinischer Hochfrequenzgeräte (Gruppe 1, Klasse A)

61000-3-2: 1995 Grenzen der Oberwellenstromemissionen
EN 61000-3-3: 1995 Grenzen der Spannungsschwankungen und Flimmern

73/23/EEC Niederspannungsrichtlinie zu entsprechen

EN 61010-1: 1993 Grenzwerte und Methoden zur Messung von Funkstörungseigenschaften von industriellen, wissenschaftlichen und medizinischen Hochfrequenzgeräten (Klasse A)

Declara que el producto siguiente:

Español

Designación: Serie 935
 Números de modelos: 935A or B - 1C (C D o K) (0 o 1) - (Cualquier combinación de cuatro números y letras)
 Clasificación: Control, Categoría de instalación II, Grado de Contaminación Ambiental II
 Tensión nominal: 100 a 240 V~ o 24 a 28 V ~
 Frecuencia nominal: 50/60 Hz
 Consumo nominal de energía: 6 VA máximo

Cumple con los requisitos esenciales de las siguientes Directivas de la Unión Europea, usando las secciones pertinentes de las reglas normalizadas y los documentos relacionados que se muestran:

89/336/EEC - Directiva de Compatibilidad Electromagnética

EN 50082-2: 1995 Norma de inmunidad genérica del EMC, Parte 2: Ambiente industrial

EN 61000-4-2: 1995 Descarga electrostática
 EN 61000-4-4: 1995 Perturbaciones transitorias eléctricas rápidas
 EN 61000-4-3: 1996 Inmunidad radiada
 EN 61000-4-6: 1996 Inmunidad conducida
 ENV 50204: 1995 Teléfono portátil

EN 50081-2: 1994 Norma de emisión genérica del EMC, parte 2: Ambiente industrial

EN 55011: 1991 Límites y métodos de medición de características de perturbaciones de radio correspondientes a equipos de radiofrecuencia industriales, científicos y médicos (Grupo 1, Clase A)

EN 61000-3-2: 1995 Límites para emisiones de corriente armónica
EN 61000-3-3: 1995 Limitaciones de fluctuaciones del voltaje

73/23/EEC Directiva de baja tensión

EN 61010-1: 1993 Requerimientos de seguridad para equipos eléctricos de medición, control y uso en laboratorios, Parte 1: Requerimientos generales

Erwin D. Lowell

Winona, Minnesota, USA

Name of Authorized Representative

Place of Issue

General Manager

May 14, 1996

Title of Authorized Representative

Date of Issue

Signature of Authorized Representative

(1226)

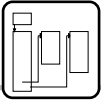

935B Software Map

Operations Menu

Prompt	Range	Default	Hidden if *	Your Settings
<input type="text" value="SP"/> Primary Set Point	<input type="text" value="rL"/> <input type="text" value="rH"/> Select a value, adjustable between Input Type Range Low and Input Type Range High.	75°F or 23°C	Appears always	
<input type="text" value="Aut"/> Auto-tune	<input type="text" value="no"/> <input type="text" value="YES"/> Choose YES to Auto-tune the 935A.	no	<input type="text" value="LR9"/> = <input type="text" value="A"/>	
<input type="text" value="AL0"/> Alarm Low	<input type="text" value="RH1"/> Select a value, adjustable between Range Low and Alarm High.	Type J Range Low	<input type="text" value="LR9"/> = <input type="text" value="0"/> ; or if <input type="text" value="DET1"/> and <input type="text" value="DET2"/> ≠ <input type="text" value="ALPT"/>	
<input type="text" value="RH1"/> Alarm High	<input type="text" value="rLO"/> Select a value, adjustable between Alarm Low and Range High.	Type J Range High	<input type="text" value="LR9"/> = <input type="text" value="0"/> ; or if <input type="text" value="DET1"/> and <input type="text" value="DET2"/> ≠ <input type="text" value="ALPT"/>	
<input type="text" value="ETPT"/> Countdown Timer	<input type="text" value="0000"/> Select a countdown time value, adjustable between 00:00 and 99:59 hrs:mins or min:sec.	0	<input type="text" value="LR9"/> = <input type="text" value="0"/> ; or if <input type="text" value="DET2"/> ≠ <input type="text" value="ETPT"/> or <input type="text" value="ETTS"/>	
<input type="text" value="idLE"/> Idle Set Point Type	<input type="text" value="LRAc"/> <input type="text" value="rL"/> <input type="text" value="rH"/> Choose an idle Set Point. Trac is an Idle Set Point equal to the Primary Set Point; or select a value between Input Type Range Low and Input Type Range High.	<input type="text" value="LRAc"/>	<input type="text" value="LR9"/> = <input type="text" value="0"/> ; or if <input type="text" value="DET2"/> ≠ <input type="text" value="ETPT"/> or <input type="text" value="ETTS"/>	

*NOTE:
 All prompts, except and , are hidden if = .

Prompt	Range	Default	Hidden if *	Your Settings
P i d PID Menu	<input type="text" value="no"/> <input type="text" value="YES"/> Choose YES to move to the PID Menu.	no	<input type="text" value="ERR"/> = <input type="text" value="P"/>	
C n F 9 Configuration Menu	<input type="text" value="no"/> <input type="text" value="YES"/> Choose YES to move to the Configuration Menu.	no	The front panel is locked out.	
P b h Proportional Band Heat	<input type="text" value="0"/> <input type="text" value="999"/> <input type="text" value="0"/> <input type="text" value="555"/> <input type="text" value="0.0"/> <input type="text" value="999.0"/> <input type="text" value="0.0"/> <input type="text" value="555.0"/> Select a value in whole degrees (0°F to 999°F or 0°C to 555°C) or in tenths of degrees (0.0°F to 999.0°F or 0.0°C to 555.0°C).	25°F or 17°C	<input type="text" value="ERR"/> = <input type="text" value="P"/> ; or if <input type="text" value="0E1"/> and/or <input type="text" value="0E2"/> ≠ <input type="text" value="HERE"/>	
h y s h Hysteresis Heat	<input type="text" value="1"/> <input type="text" value="999"/> <input type="text" value="1"/> <input type="text" value="555"/> <input type="text" value="0.1"/> <input type="text" value="999.0"/> <input type="text" value="0.1"/> <input type="text" value="555.0"/> Select a value in whole degrees (1°F to 999°F or 1°C to 555°C) or in tenths of degrees (0.1°F to 999.0°F or 0.1°C to 555.0°C).	3°F or 2°C	<input type="text" value="ERR"/> = <input type="text" value="P"/> ; or if <input type="text" value="P b h"/> ≠ 0	

Prompt	Range	Default	Hidden if *	Your Settings
ct h Cycle Time Heat	<input type="text" value="0.1"/> <input type="text" value="60.0"/> <input type="text" value="5.0"/> <input type="text" value="60.0"/> Select a value between 0.1 and 60.0 seconds (Solid-State Relay or Switched DC) or 5.0 and 60.0 seconds (Electromechanical Relay).	1.0 second	<input type="text" value="ERR"/> = <input type="text" value="P"/> or if <input type="text" value="Pb h"/> = 0	
<input type="text" value="db"/> Dead Band	<input type="text" value="0"/> <input type="text" value="999"/> <input type="text" value="0"/> <input type="text" value="555"/> <input type="text" value="0.0"/> <input type="text" value="999.0"/> <input type="text" value="0.0"/> <input type="text" value="555.0"/> Select a value in whole degrees (0°F to 999°F or 0°C to 555°C) or in tenths of degrees (0.0°F to 999.0°F or 0.0°C to 555.0°C).	0°F or 0°C	<input type="text" value="ERR"/> = <input type="text" value="P"/> or if <input type="text" value="DE1"/> = <input type="text" value="cool"/> and <input type="text" value="DE2"/> ≠ <input type="text" value="HERE"/> or if <input type="text" value="DE1"/> = <input type="text" value="HERE"/> and <input type="text" value="DE2"/> ≠ <input type="text" value="cool"/>	
<input type="text" value="Pb c"/> Proportional Band Cool	<input type="text" value="0"/> <input type="text" value="999"/> <input type="text" value="0"/> <input type="text" value="555"/> <input type="text" value="0.0"/> <input type="text" value="999.0"/> <input type="text" value="0.0"/> <input type="text" value="555.0"/> Select a value in whole degrees (0°F to 999°F or 0°C to 555°C) or in tenths of degrees (0.0°F to 999.0°F or 0.0°C to 555.0°C).	25°F or 17°C	<input type="text" value="ERR"/> = <input type="text" value="P"/> or if <input type="text" value="DE1"/> ≠ <input type="text" value="cool"/> and/or <input type="text" value="DE2"/> ≠ <input type="text" value="cool"/>	
<input type="text" value="hysc"/> Hysteresis Cool	<input type="text" value="1"/> <input type="text" value="999"/> <input type="text" value="1"/> <input type="text" value="555"/> <input type="text" value="0.1"/> <input type="text" value="999.0"/> <input type="text" value="0.1"/> <input type="text" value="555.0"/> Select a value in whole degrees (1°F to 999°F or 1°C to 555°C) or in tenths of degrees (0.1°F to 999.0°F or 0.1°C to 555.0°C).	3°F or 2°C	<input type="text" value="ERR"/> = <input type="text" value="P"/> or if <input type="text" value="Pb c"/> ≠ 0	

Prompt	Range	Default	Hidden if *	Your Settings
<p>CT c</p> <p>Cycle Time Cool</p>	<p>0.1 60.0</p> <p>5.0 60.0</p> <p>Select a value between 0.1 and 60.0 seconds (Solid-State Relay or Switched DC) or 5.0 and 60.0 seconds (Electromechanical Relay).</p>	5.0 seconds	<p>LAG = P;</p> <p>or if</p> <p>Pb c = 0</p> <p>or if</p> <p>Pb c is hidden</p>	
<p>IT</p> <p>Integral Function</p>	<p>0.0 99.99</p> <p>Select a value, adjustable between 0.0 and 99.99 minutes/repeat.</p>	5.00 minutes/repeat	<p>LAG = P;</p> <p>or if</p> <p>Pb h = 0;</p> <p>or if</p> <p>Pb h is hidden; and if Pb c = 0;</p> <p>or if</p> <p>Pb c is hidden</p>	
<p>dE</p> <p>Derivative Function</p>	<p>0.00 9.99</p> <p>Select a value, adjustable between 0.00 and 9.99 minutes.</p>	0 minutes	<p>LAG = P;</p> <p>or if</p> <p>Pb h = 0;</p> <p>or if</p> <p>Pb h is hidden; and if Pb c = 0;</p> <p>or if</p> <p>Pb c is hidden</p>	
<p>CAL</p> <p>Calibration Offset</p>	<p>-999 9999</p> <p>-99.9 999.9</p> <p>Select a value, adjustable between -999° and 9999°F or C or -99.9° and 999.9°F or C to eliminate a difference between the displayed temperature and the actual temperature.</p>	0°F or 0°C	<p>LAG = P</p>	

Prompt	Range	Default	Hidden if *	Your Settings
<input type="text" value="In"/> Input Type	<input type="text" value="J"/> J t/c <input type="text" value="H"/> K t/c <input type="text" value="E"/> T t/c <input type="text" value="N"/> N t/c <input type="text" value="E"/> E t/c <input type="text" value="S"/> S t/c <input type="text" value="rtd"/> 1.0°RTD <input type="text" value="rtd"/> 0.1°RTD	J	<input type="text" value="LR9"/> = <input type="text" value="C"/>	
<input type="text" value="C_F"/> Celsius/Fahrenheit	<input type="text" value="OF"/> <input type="text" value="OC"/> Choose to indicate temperature in °Fahrenheit or °Celsius.	F	<input type="text" value="LR9"/> = <input type="text" value="C"/>	
<input type="text" value="rL"/> Range Low	<input type="text" value="In"/> <input type="text" value="rh"/> Select a value between Input Type Range Low and Input Range High.	Type J range low value	<input type="text" value="LR9"/> = <input type="text" value="C"/>	
<input type="text" value="rh"/> Range High	<input type="text" value="rL"/> <input type="text" value="In"/> Select a value between Input Type Range High and Input Range Low.	Type J range high value	<input type="text" value="LR9"/> = <input type="text" value="C"/>	
<input type="text" value="OEt"/> Output 1 Function	<input type="text" value="HEAT"/> <input type="text" value="COOL"/> <input type="text" value="ALPN"/> <input type="text" value="rSP"/> <input type="text" value="FPL"/> <input type="text" value="nonE"/> Choose Heat, Cool, Alarm, Remote Set Point, Front Panel Lock or No output action.	heat	<input type="text" value="LR9"/> = <input type="text" value="C"/>	

Prompt	Range	Default	Hidden if *	Your Settings
DE2 Output 2 Function	HEAT COOL ALRM EHPM ETMS none Choose Heat, Cool, Alarm, Timer (Hrs:Min), Timer (Min:Sec) or No output action.	none	EA9 = C	
RES Remote Timer Start	OFF FPL ETMR Choose Off, Front Panel Lock, or Timer (Hrs:Min)	Off	EA9 = 0	
DISP Display Default	Ac ACSP ACEL EIRc EISP Choose the primary (last 2 characters) and secondary (first 2 characters) Default displays. Press SET to toggle to the secondary display for 15 seconds.	Ac	EA9 = C	
ALTY Alarm Type	Prnc Pcrno dEnc dEno Choose an alarm type: Process normally closed, Process normally open, Deviation normally closed or Deviation normally open.	Prnc	EA9 = C ; or if DE1 and/or DE2 ≠ ALRM	
ALYS Alarm Hysteresis	1 999 1 555 0.1 999.0 0.1 555.0 Select a value in whole degrees (1°F to 999°F or 1°C to 555°C) or in tenths of degrees (0.1°F to 999.0°F or 0.1°C to 555.0°C).	3°F or 2°C	EA9 = C ; or if DE1 and/or DE2 ≠ ALRM	

Prompt	Range	Default	Hidden if *	Your Settings
<input type="checkbox"/> LAL Alarm Latch	<input type="checkbox"/> no <input type="checkbox"/> YES Choose YES for a Latching Alarm.	no	<input type="checkbox"/> LAG = <input type="checkbox"/> C ; or if <input type="checkbox"/> OE1 and/or <input type="checkbox"/> OE2 ≠ ALPN	
<input type="checkbox"/> SIL Alarm Silencing	<input type="checkbox"/> no <input type="checkbox"/> YES Choose YES for a Silenced Alarm on start-up or silencing during operation.	no	<input type="checkbox"/> LAG = <input type="checkbox"/> C ; or if <input type="checkbox"/> OE1 and/or <input type="checkbox"/> OE2 ≠ ALPN	
<input type="checkbox"/> FAIL Input Failure Mode	<input type="checkbox"/> BPLS <input type="checkbox"/> -100 <input type="checkbox"/> 100 Choose Bumpless Transfer or Percent Power.	Bumpless	<input type="checkbox"/> LAG = <input type="checkbox"/> C ; or if <input type="checkbox"/> OE1 and <input type="checkbox"/> OE2 ≠ HERE or COOL	
<input type="checkbox"/> ETPN Timer Output Function	<input type="checkbox"/> dLoN <input type="checkbox"/> dLoF <input type="checkbox"/> S9oN <input type="checkbox"/> S9oF Choose Delay ON, Delay OFF, Signal ON, or Signal OFF.	Delay OFF	<input type="checkbox"/> LAG = <input type="checkbox"/> C ; or if <input type="checkbox"/> OE2 ≠ ETPN or ETNS	
<input type="checkbox"/> SErk Start Timer Function	<input type="checkbox"/> IPNd <input type="checkbox"/> rdY <input type="checkbox"/> rdYA <input type="checkbox"/> PLJr Choose Immediate, Ready Band, Ready Band Acknowledge, or Power.	Immediate	<input type="checkbox"/> LAG = <input type="checkbox"/> C ; or if <input type="checkbox"/> OE2 ≠ ETPN or ETNS	
<input type="checkbox"/> rdY Timer Ready Band	<input type="checkbox"/> 0 <input type="checkbox"/> 999 <input type="checkbox"/> 0 <input type="checkbox"/> 555 <input type="checkbox"/> 0.0 <input type="checkbox"/> 999.0 <input type="checkbox"/> 0.0 <input type="checkbox"/> 555.0 If <input type="checkbox"/> SErk = <input type="checkbox"/> rdYA or <input type="checkbox"/> rdY , then select a value in whole degrees (0°F to 999°F or 0°C to 555°C) or in tenths of degrees (0.0°F to 999.0°F or 0.0°C to 555.0°C).	0°F or 0°C	<input type="checkbox"/> LAG = <input type="checkbox"/> C ; or if <input type="checkbox"/> OE2 ≠ ETPN or ETNS	

Prompt	Range	Default	Hidden if *	Your Settings
<input type="text" value="SE"/> Signal Time	<input type="text" value="1"/> <input type="text" value="9959"/> If <input type="text" value="E1P7"/> = <input type="text" value="5900"/> or <input type="text" value="590F"/> , then select a value between 00:01 and 99:59 min:sec.	00:01	<input type="text" value="E89"/> = <input type="text" value="C"/> ; or if <input type="text" value="E1P7"/> ≠ <input type="text" value="5900"/> or <input type="text" value="590F"/>	
<input type="text" value="SLOC"/> Set Point Lockout	<input type="text" value="no"/> <input type="text" value="YES"/> Choose YES to Lock the Primary Set Point.	no	<input type="text" value="E89"/> = <input type="text" value="C"/>	
<input type="text" value="E89"/> Lockout Tag	<input type="text" value="PCOR"/> <input type="text" value="COR"/> <input type="text" value="PCO"/> <input type="text" value="CO"/> <input type="text" value="PCA"/> <input type="text" value="CA"/> <input type="text" value="PC"/> <input type="text" value="C"/> <input type="text" value="POR"/> <input type="text" value="OR"/> <input type="text" value="PO"/> <input type="text" value="O"/> <input type="text" value="PA"/> <input type="text" value="A"/> <input type="text" value="P"/> <input type="text" value=""/> Choose the menus/functions that will not be displayed, and therefore cannot be changed. P = PID Menu C = Configuration Menu (except tag) O = Operations Menu (except <input type="text" value="CONF9"/>) A = Auto-tune	P	Always appears	

About Watlow Winona

Watlow Winona is a U.S. division of Watlow Electric Manufacturing Company, St. Louis, Missouri, a manufacturer of industrial electric heating products since 1922. Watlow products include electric heaters, sensors, controllers and switching devices. The Winona operation has been designing solid-state electronic control devices since 1962, and has earned the reputation as an excellent supplier to original equipment manufacturers. These OEMs and end users depend upon Watlow Winona to provide compatibly engineered controls that they can incorporate into their products with confidence. Watlow Winona resides in a 100,000-square-foot marketing, engineering and manufacturing facility in Winona, Minnesota.

Warranty

The Watlow Series 935 is warranted to be free of defects in material and workmanship for 36 months after delivery to the first purchaser for use, providing that the units have not been misapplied. Since Watlow has no control over their use, and sometimes misuse, we cannot guarantee against failure. Watlow's obligations hereunder, at Watlow's option, are limited to replacement, repair or refund of purchase price, and parts which upon examination prove to be defective within the warranty period specified. This warranty does not apply to damage resulting from transportation, alteration, misuse, or abuse.

Returns

- Call or fax your distributor or the nearest Watlow sales office for best information about returns. (See outside back cover.)
- To return directly to Watlow Winona in the U.S., first call or fax Customer Service for a Return Material Authorization (RMA) number (telephone: +1 (507) 454-5300; fax: +1 (507) 452-4507).
- Put the RMA number on the shipping label, along with on a written description of the problem.
- A restocking charge of 20% of the net price is charged for all standard units returned to stock.

How to Reach Us



Quality and Mission Statement:

To position Watlow Winona as the world's best supplier of superior thermal solutions, by exceeding the expectations of our customers, shareholders, and employees.

Your Authorized Watlow Distributor:

Europe:

Watlow Electric GmbH
Lauchwasenstr. 1, Postfach 1165,
Kronau 76709 Germany
Telephone: +49 (0) 7253 9400
Fax: +49 (0) 7253 9400 99

Watlow France S.A.R.L.
Immeuble Somag, 16 Rue Ampère,
Cergy Pontoise Cedex 95307 France
Telephone: +33 (1) 3073 2425
Fax: +33 (1) 3073 2875

Watlow Italy S.r.l.
Via Meucci 14
20094 Corsico, Milano Italy
Telephone: +39 (02) 458 8841
Fax: +39 (02) 458 69954

Watlow Limited
Robey Close, Linby Industrial Estate,
Linby, Nottingham NG15 8AA England
Telephone: +44 (0) 115 9640777
Fax: +44 (0) 115 9640071

Asia/Pacific:

Watlow Australia Pty., Ltd.
3 Belmont Place, Gladstone Park,
Tullamarine, Victoria 3043 Australia
Telephone: +61 (3) 9335 6449
Fax: +61 (3) 9330 3566

Watlow China, Inc.
179, Zhong Shan
Hong Qiao Cointek Bldg, Fl. 4, Unit P
Shanghai 200051 China
Telephone: +86 21-6229-8917
Fax: +86 21-6228-4654

Watlow Japan Ltd. K.K.
Azabu Embassy Heights 106,
1-11-12 Akasaka,
Minato-ku, Tokyo 107-0052 Japan
Telephone: +61 (3) 9335 6449
Fax: +61 (3) 9330 3566

Watlow Korea
3rd Fl. DuJin Bldg.
158 Samsun-dong, Kangnam-ku
Seoul, 135-090 Korea
Telephone: +82 (02) 563 5777
Fax: +82 (02) 563 5779

Watlow Singapore Pte. Ltd.
Blk, 55, Ayer Rajah Crescent, #3-23,
Ayer Rajah Industrial Estate,
Singapore 139949
Telephone: +65 777 5488
Fax: +65 778 0323

Watlow Electric Taiwan
10F-1 No. 189,
Chi-Shen 2nd Road,
Kaohsiung, Taiwan
Telephone: +886 (0) 7 261 8397
Fax: +886 (0) 7 261 8420

Watlow-Penang
38-B Jalan Tun Dr. Awang
Bayan Lepas
Penang, Malaysia 11900
Telephone: +60 (4) 641-5977
Fax: +60 (4) 641-5979

Latin America:

Watlow de México
Av. Fundación #5,
Col. Parques Industriales,
Querétaro, Qro. México CP-76130
Telephone: +52 (42) 17 6235
Fax: +52 (42) 17 6403

For other information:

Watlow FAX REPLY: (908) 885-6344 (outside the U.S.); or (800) 367-0430 (inside the U.S.)