

## Pre Installation

- Check to make sure that heater received is the same as that ordered.
- Elements may come in contact with each other during shipment. Minor adjustments to elements may be required prior to installation to separate them. Extensive bending of elements should be avoided since dielectric strength between coil and sheath may be compromised.
- Watlow heaters are built to comply with UL and CSA dielectric requirements, it may be necessary due to atmospheric conditions / humidity, to perform a dielectric test prior to startup. (Refer to **megohm test** under **Installation** section)

## Safety

**Electric heaters are inherently dangerous!!** Care should be taken to read and completely understand the Installation and Maintenance manual before installing and wiring the heater. Any installation and maintenance performed on the heater shall be done by a qualified electrician, in accordance with the "National Electric Code" and other electrical codes as they apply. It is the users responsibility to ensure that the heater being used is properly selected and installed in the application.



The Caution Symbol (exclamation point) alerts you to a "**CAUTION**", a safety or functional hazard which could affect your equipment or its performance.



The warning symbol (lightning bolt) alerts you to a "**WARNING**", a safety hazard which could affect you and the equipment

## Installation

Proper heater selection and installation will result in efficient heat transfer, safe operation, and long heater life.

### 1. Megohm precheck

During shipping and/or storage, the possibility of moisture absorption by the insulation material within the element is possible. To ensure proper megohm values a minimum 500 VDC megohm meter (Megger) should be used to ensure that the megohm reading between the heater terminal and the heater sheath is more than 10 megohms when the unit is at room temperature.

If several units are interconnected, the megohm of the heater is obtained by taking the reading and dividing by the number of interconnected elements. This reading should be greater than 10 megohms.

If a low megohm value exists, two alternative methods can be used to remedy the situation. The best method is to remove all terminal hardware, and bake out the heater at no higher than 250°F (120°C) overnight or until an acceptable reading is reached. The second method is to energize the unit at low voltage in air until the megohm is at an acceptable reading. Care should be taken to prevent the heater sheath from exceeding 750°F (398°C) for Incoloy®.

### 2. Protection of heater elements from over temperature

The use of temperature controls to regulate heating process and prevent heater over temperature is highly recommended to ensure safe heater operation. It is the users responsibility to ensure safety of the installation. Individual heater modules are designed to accommodate optional high limit thermocouple kit.



**WARNING: Install high temperature control protection in systems where an over temperature fault condition could present a fire hazard or other hazard. Failure to install temperature control**

---

*protection where a potential hazard exists could result in damage to equipment and property, and injury to personnel.*

Failure of components in a temperature control loop, such as the sensor, heater control relay or main temperature control, can result in damage to a product in process, a melt down of a heater, and / or damaging fire.

To protect against this possibility, over temperature protection must be provided to interrupt or remove power from the heater circuit. **A bulb and capillary thermostat is not recommended for this function since it may not respond quickly enough to adequately protect the heater. In cases where the thermostat bulb gets too hot before the system is turned off, the thermostat bulb could rupture. This could result in the thermostat remaining in the "ON" condition since there is insufficient fluid to move contacts apart.** We recommend the temperature protection have appropriate third party approval, and be applied in the classification for which it was tested and approved.

### **3. Terminal Enclosures**

The product accompanying this manual does not come standard with a terminal enclosure. It is the customer's responsibility to provide a terminal enclosure that meets the safety and application requirements of the specific application. An optional general purpose enclosure is available from the factory if the user so desires.

Terminal enclosures should be designed to be compatible with the environment in which the heater will be located. It is the users responsibility to determine the need for correct rating of the electrical housing. This should be based on appropriate national and local electrical codes. Failure to use a compatible enclosure could result in heater damage and personnel danger.

The optional terminal enclosure is designed for general purpose use and is rated NEMA 1. These enclosures should be applied where there will be no danger of spilled liquids, dampness, dirt, and gaseous conditions.

Units should be located in an area that will minimize the chance of being hit by falling or moving objects. The terminals must be protected at all times from moisture or vapor.

In order to maintain termination integrity, the terminal enclosure should be kept below 400°F (204°C).

### **4. Orientation / Mounting**

An appropriate full scale cutout with dimensions for the heater module is attached. The duct heater may be mounted vertically, or horizontally, from the left to right, top or bottom. The inlet side of the unit must be at least 48" downstream from any transition in duct size or direction, or from any air handling equipment. Care should be taken to properly support heater module to duct. A support plate can be used to accomplish this. See Figure 1 for locations that should be avoided.

Heaters may be ganged in parallel for nearly any total wattage desired. The temperature control thermocouple if so equipped should be located near the work to sense exiting air temperature. Conduct process temperature sensing in the outlet stream away from the heater.

Minimum air velocity through the heater is 200 fpm for air temperatures approaching 800°F (412°C). Lower velocities will jeopardize element life.

Air flow over the entire face of the heater should be uniform at the design velocity.

# **WATLOW ELECTRIC MFG CO.**

**WATROD Duct Heater (module only) I& M Manual**

**I&M NUMBER: 316-42-16-1**

**Date: 11/25/2013**

**Page: 3**  
**Rev: 4.00**

---

The units screw or bolt in place through the 9/32" dia. holes in the mounting flange. A 1/4-20 Allen head

# WATLOW ELECTRIC MFG CO.

WATROD Duct Heater (module only) I & M Manual

I&M NUMBER: 316-42-16-1

Date: 11/25/2013

Page: 4

Rev: 4.00

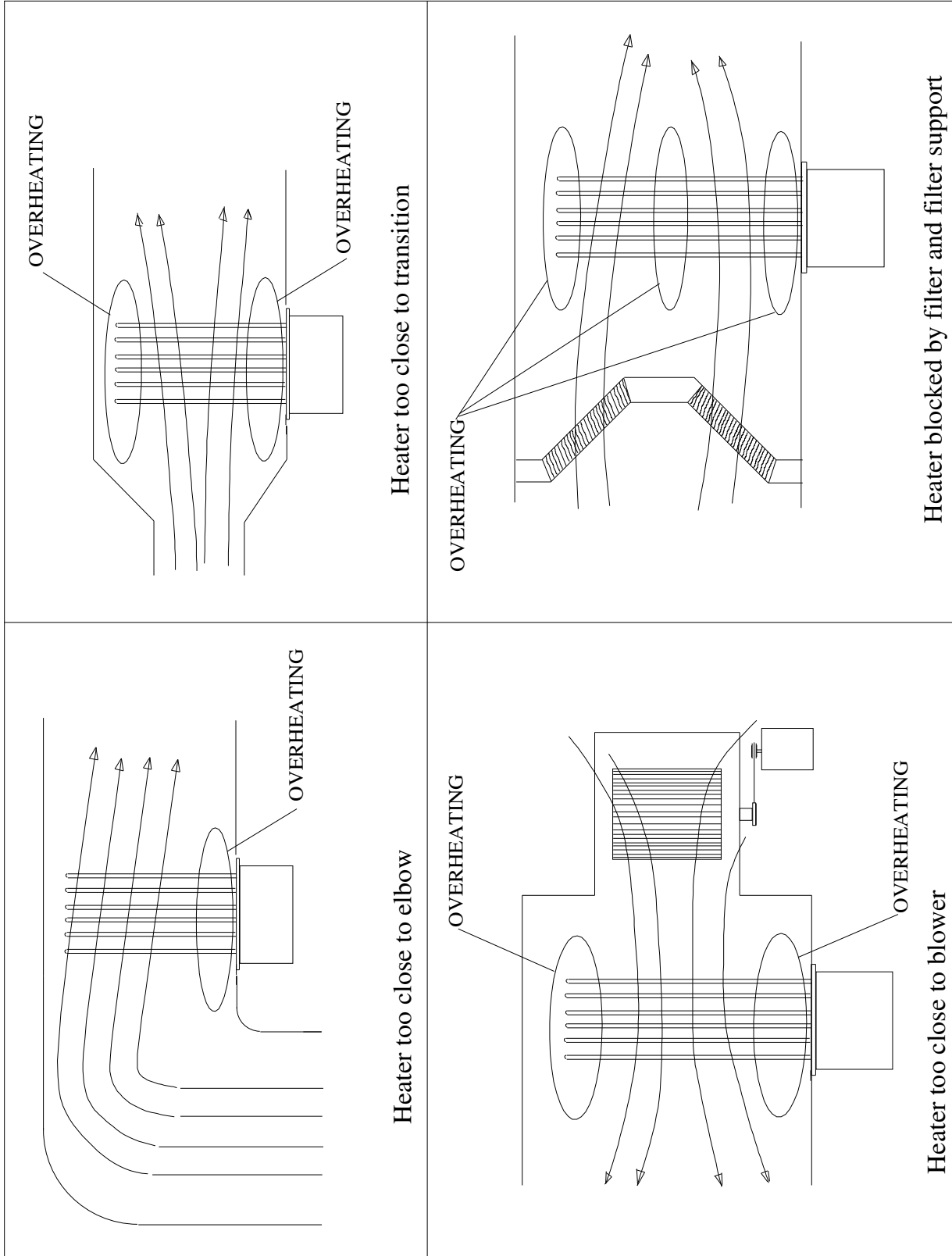

**Figure # 1**

screw in combination with a split lock washer is suggested for mounting the heater to the ductwork.

**DANGER: HAZARD OF FIRE.** Electric heaters are capable of developing high temperatures so extreme care should be taken to locate heaters in safe environments. Mounting heaters in atmospheres containing combustible gases and vapors should be avoided. According to article 501 of the NEC, the maximum surface temperature of the heater shall not exceed 80 % of the auto-ignition of the surrounding atmosphere when the heater is continuously energized. Care should also be taken to keep combustible materials far enough away to be free of the effects of high temperatures.

**5. Wiring**

**WARNING; HAZARD OF ELECTRIC SHOCK.** Any installation involving electric heaters must be grounded to earth to eliminate shock hazard.



Electrical wiring to the heaters must be installed in accordance with the National Electric Code and any state and local electrical code by qualified personnel.

Consult wiring diagram supplied with the unit for correct feeder wires connections. If one is not supplied, the factory should be consulted for the appropriate wiring diagram. Feeder wire should be properly selected based on amperage, electrical power rating, ambient temperature, and type of environment. Feeder wire should also be housed in either rigid or flexible conduit which carries the same classification as the heater enclosure. It is the users responsibility to properly size and install feeder wire.

Feeder wire line connections may be made directly to stud terminals or box type compression fittings. Box type compression fittings will accept a #4 AWG maximum wire while stud terminals will accept a #10 ring connector(T&B, Amp, etc.). It is essential that these connections be tight. Stud terminals should be tightened to a maximum torque of 20 in-lbs while the bottom nut is supported. Ground connection (color coded "green") is supplied inside the housing for ground wire. NOTE: Stud terminals that do not have a bussbar or factory installed ring connector should only be tightened to 9 in-lbs.

Line voltage must be equal to or less than rating stamped on the heater assembly.

The power circuit is required to include a branch circuit overcurrent protective device, a disconnect and a secondary thermal cut-out with manual reset. The control circuit should include the temperature controller, the primary thermal cut-out and an interlock with the fan motor. One method to do this is with a pressure air flow switch. It will open the control circuit and de-energize the heater when any circumstance prevents sufficient air flow through the heater.

The air handler should be set up to run on a time delay after the heater is de energized. The correct time delay will depend on the blower rating, amount of duct insulation, and the total power output of heaters(s). The time delay allows the elements to cool and prevents overheating the adjacent duct and terminal areas.

**Start Up**

Before energizing the heater the following items should have been checked with the heater power disconnected:

1. Electrical termination is tight and wiring is per wiring diagram supplied with heater
2. Proper disconnecting means and fusing have been installed
3. The voltage rating of the heater is the same as that being applied
4. Megohm is within acceptable limits
5. Proper temperature controls and safety limiting devices are in place
6. Heater is securely installed in duct

After applying power to the heater make sure that the system is being controlled properly before leaving it to run unattended. Failure to do this could result in overheating resulting in personnel danger and fire.

<b>Troubleshooting</b>	
<b>PROBLEM</b>	<b>Cause / Correction</b>
No power available to heater	Check disconnect switch to ensure it is in the "ON" position and that fuses are not blown. Replace fuses if they are blown
Fuses blowing	Check heater electrical rating. Applied voltage may be wrong Check fuse rating. Fuses should be at least 25% more than full load amperage. Disconnect heater power source. Check the heater resistance to ground. This should be no less than 1 Megohm. Refer to Megohm checking.
Not enough power	Check line voltage to ensure it is within specification Check full line current if voltage is correct. If line current is lower, the heater may be wired wrong or has open elements
Air not heating to desired temperature	Not enough Kw or incorrect voltage being applied Too much heat loss, higher wattage heater may be required
High limit tripping / alarm	Not enough fluid flow Too much Kw Line voltage higher than designed / allowable



### **Preventative Maintenance**

**CAUTION: HAZARD OF ELECTRIC SHOCK. TURN ALL POWER TO HEATER OFF, USE APPROPRIATE DISCONNECT LOCKOUTS AND ALLOW SYSTEM/HEATER TO COOL BEFORE PERFORMING ANY MAINTENANCE**

Check line connections to make sure they are tight, free of oxide build-up, and that no dust or dirt build-up is present. Re tighten to 20 in-lbs as necessary. NOTE: Stud terminals that do not have a bussbar or factory installed ring connector should only be tightened to 9 in-lbs.

### **Replacement Parts**

Reference the module heater part number on the flange when ordering replacement parts. Recommended spare parts would be : a heater module, and high limit thermocouple or high limit thermocouple kit.

#### **To replace heater module:**

- a) Disconnect power and then feeder wire
- b) Remove terminal hardware connecting module to be replaced and other adjacent modules.
- c) Remove the two Allen head screws and split washers holding module to ductwork.
- d) Pull module through duct as shown below.
- e) Reinstall new module through duct wall and retighten using Allen head screws and split washers.

- f) Reinstall jumpers and feed wire
- g) Check circuit resistance to ensure that modules have been properly wired

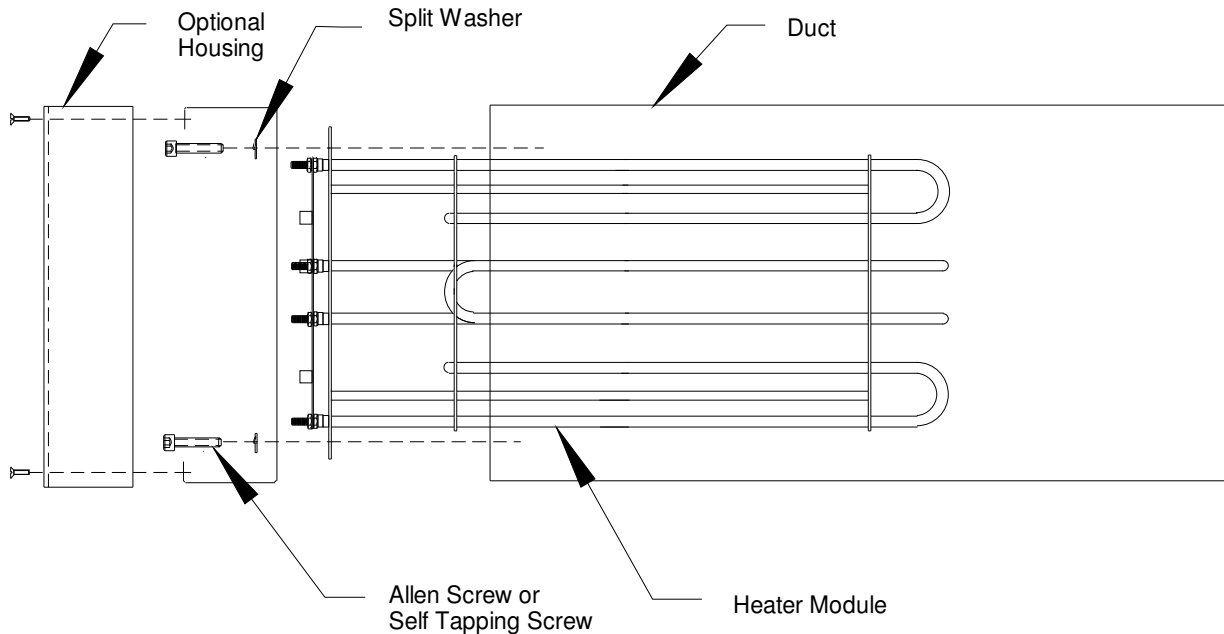

**To install high limit thermocouple kit:**

- a) Perform steps a - d above.
- b) Use a 11/32" drill to drill a pilot hole at the location depicted by the "+" mark shown on the flange below.

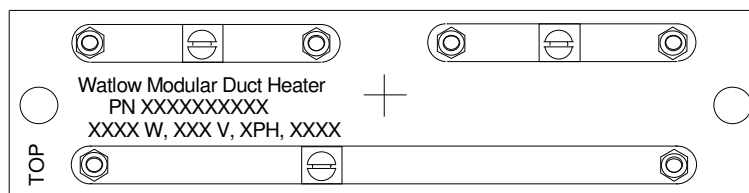

- c) Use a 1/8 NPT tap to thread the hole drilled in step b. **Make certain that the hole being tapped is perpendicular to the flange.** If it is not perpendicular, electrical shorting may occur between the compression fitting and the nearby electrical jumpers.
- d) Thread the lower portion of the compression fitting in the hole tapped above.
- e) Insert thermocouple through lower portion of compression fitting threaded into flange and through hole in upper support bracket until transition fitting of thermocouple is bottomed out.
- f) Tighten upper portion of compression fitting to firmly hold thermocouple in place.
- g) Wrap thermocouple as shown in the diagram below about two times on a 2" diameter.
- h) Attach tip of thermocouple to mid section of element using the hose clamp provided. The tip of the thermocouple should not be covered by the hose clamp, but should extend about 3/16" from the hose clamp.
- i) Pass heat shrink provided over thermocouple leads and compression fitting. Heat shrink sleeving so that it adheres to the shape of the compression fitting and thermocouple.

# WATLOW ELECTRIC MFG CO.

WATROD Duct Heater (module only) I& M Manual

I&M NUMBER: 316-42-16-1

Date: 11/25/2013

Page: 8  
Rev: 4.00

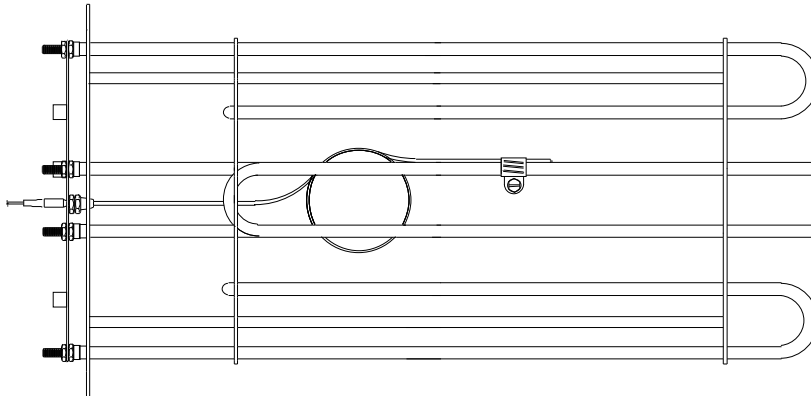

Contact your local Watlow distributor for ordering replacement parts. Check the Yellow Pages under "Electrical Heating Elements" in the largest industrial area nearest you.

## Warranty

Watlow warrants its products against defects in material and workmanship for 12 months from the date of delivery for custom products and 18 months for stock products providing such products are properly applied, used and maintained. Watlow does not warrant any product against damage from corrosion, contamination, misapplication, improper specification or operating conditions beyond our control. The terms of this warranty are the exclusive terms available to any person. No person has authority to bind the Company to representation or warranty other than this warranty. Watlow is not liable for incidental or consequential damages resulting from use of the product whether a claim for such damages is based upon warranty, contract, negligence or other fault. Should any product fail under these warranty conditions it will be repaired or replaced at no charge. Advanced authorization must be obtained within 30 days of failure.

## Return Policy

1. Call Watlow Industries at 573-221-2816, for a Return Material Authorization (RMA) number before returning any item for repair or replacement. The following information is needed to process a returned heater expeditiously:
  - Customer name
  - Contact Name
  - Part number
  - Quantity
  - Reason for return
  - Application information
  - MSDS sheet of material(s) that came in contact with heater, if used.
  - Customer account number
  - Phone Number
  - P.O. number
2. Prior approval and an RMA number is needed when returning any unused product for credit. Make sure the RMA number is on the outside of the carton, and on all paperwork. Return all material Freight Prepaid basis.
3. Stock heaters and accessories which have not been used or modified can be returned to the plant for a 20% restocking charge. Modified stock units can only be returned, if they are not permanently modified, for a minimum 30% restocking charge.
4. All stock and modified stock must have a date code no later than 2 years from the date of shipment.



# WATLOW ELECTRIC MFG CO.

WATROD Duct Heater (module only) I& M Manual

I&M NUMBER: 316-42-16-1

Date: 11/25/2013

Page: 9  
Rev: 4.00

---

## REVISIONS

LEVEL	DESCRIPTION	INITIALS	DATE
1.00	PART TYPE WAS MFG	SAM	06-12-96
1.98			
2.00	ADDED "Date:6/11/2008" TO HEADER PER ECO HAN2838	TBR	06-11-08
3.00	ADDED 9 in-lb note pgs 4 & 5 PER ECO EC300	NKH	7-11-11
4.00	Updated Watlow company name, was Watlow IND EC2928	JPH	11/25/13