

Large-Tank Heating Systems



RSTO

LTFX

Description

Chromalox offers four uniquely designed electric heating systems for large storage tanks. The systems can be installed in above or below-ground tanks made of steel, concrete, or fiberglass.

Complete with Chromalox® controls, these large-tank heating systems can be operated with little or no manual attention. Heat can be applied by using strategically located sensors to monitor tank temperatures and energize the heaters. The heating operation may be fully automated by using timers and controllers to program the start and stop of both off-peak and daytime heating functions.

In addition to operating convenience, Chromalox® large-tank electric heating systems require very little upkeep and are practically maintenance-free. The result is substantially reduced operating costs over alternative heating methods.



FXTH



OCE

Open Coil Element Pipe Insert Heaters

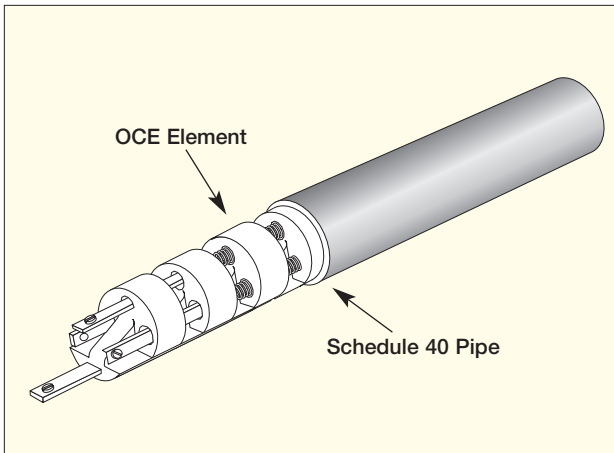

Applications

Chromalox® OCE open coil element large-tank electric heaters installed inside 2- or 3-inch Schedule 40 NPS pipe provide uniform heat over a large surface area. This method of indirect heating lowers the watt density or heat flux on the surface area of the pipe in contact with the heated media, reducing the tendency to coke or break down heat-sensitive materials.

Features

Easy installation	Requires only 3 feet for installation or removal in cramped areas
Highly flexible	Can be bent in a vertical plane at minimum 12-inch radius
Heavy-gauge bus bars	Provide spacing of heated section away from terminal area
Heavy-gauge resistance wire	Provides reliable service and long element life

Construction

Heavy-gauge resistance wire coils are mounted into high-density electrical ceramics. The ceramics are strung on a continuous support bar to provide sufficient rigidity to insert the assembly into 2- or 3-inch Schedule 40 NPS steel pipe for installation in tanks.

General Specifications

Available Diameters	1.875 and 2.750 in. OD
Lengths	60 to 320 in. (5 to 26 ft)
Operating Temperature	0° to 750°F
Single Element Rating	4 to 20 kW
Watt Density	3 to 12 W/in. ²
Voltage	240 and 480 Vac, 3 Phase

Large Tank Flange Heaters (LTFX)

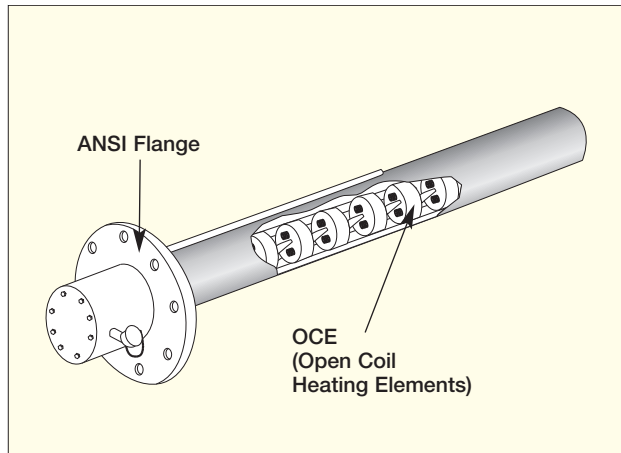

Applications

LTFX heaters provide low-watt-density heating over a large surface area while providing precise temperature control for such materials as fire water storage, asphalt, diesel lube oils, ethanol, bio-diesel fuel, glycerin, animal fats, vegetable oils, fuel oils, or similar types of liquids.

Features

No tank draining	Heating elements can be inspected or changed without the need to drain the tank, saving both time and money
Minimal space	OCE-style elements can be bent during insertion or removal to a vertical plane with as little as 12 inches of clearance
Matching control panel	Each unit can be matched with a corresponding control panel, mounted separately or installed directly on the LTFX heater, to ensure seamless operation
Quick & easy installation	Standard ANSI flange provides a straightforward mating connection with no special modifications
Overtemperature sensor	Each unit comes equipped with a type J thermocouple for temperature sensing on the pipe wall
Clean, pollution-free electric heat	No open flames, no additional plumbing connection, quiet operation, and better efficiencies with precise control and simple operation

General Specifications

Connection Size	4 to 14 in., 150# ANSI Flange
Immersion Length5 to 25 ft
Operating Temperatures	0° to 750°F
Element Rating	4 to 240 kW
Voltage	240 and 480 Vac, 3 Phase

Flexible Tank Heaters

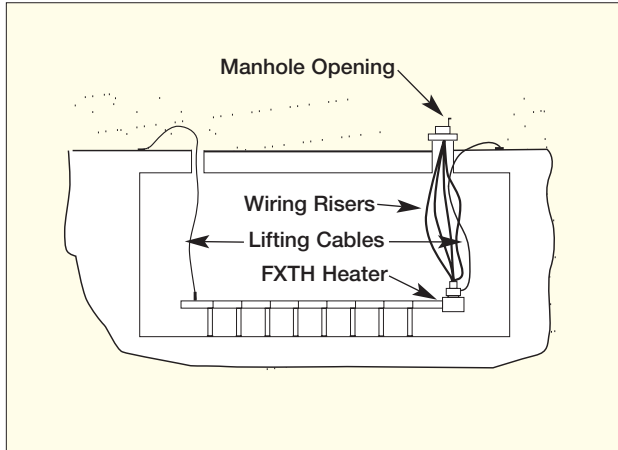

Applications

Chromalox® FXTH flexible tank heaters provide low-watt-density heating for viscous materials such as asphalt, fuel oil, pitch and tar, liquid sugar, molasses, lube oils, linseed oil, and other heat-sensitive materials.

These heaters are particularly useful for storage tanks that are underground or when the tank ends are inaccessible for installation of more conventional heaters. They can be installed through the normal manhole opening of many large tanks above or below ground without requiring modification to the tank itself. Chromalox® FXTH flexible tank heaters can be used in steel, concrete, and fiberglass tanks or in open-top process tanks.

Construction

The basic heater assembly consists of carbon steel flexible pipe, terminal enclosure, 14-foot risers, two lifting cables, and 4-inch-high sludge legs. Stainless steel is also available.

Optional Control Center

An optional Chromalox® NEMA 4 weatherproof or NEMA 12 oil- and dust-tight electrical control center is available completely wired with indicating electronic process control, fail-safe overtemperature controls, master circuit breaker, contactors, fuses, pilot lights, switches, and control transformer. Other control options include digital chart recorders, timers, and audible alarm.

One control center can control multiple heaters in the same tank. The control center is mounted remotely on mounting legs or with vertical wall-mounted brackets and has a padlock.

Features

<p>No tank modification required</p> <p>No hot spots or carbonization</p> <p>Low profile</p> <p>High wattage at low watt density</p> <p>Durable</p> <p>Weatherproof terminal enclosure</p>	<p>Installs through normal manhole opening with no cutting or welding</p> <p>Heat is evenly spread along the bottom of the tank</p> <p>Provides maximum use of the tank volume and maintains heat even at low levels</p> <p>Plenty of capacity without overheating the material</p> <p>Uses long-lasting Chromalox® open coil heaters</p> <p>Contains process and overtemperature thermocouples; overtemperature thermowell (one per tube) is attached to the heater sheath</p>
--------------------------------------------------------------------------------------------------------------------------------------------------------------------------------------------------------------------------------------	---------------------------------------------------------------------------------------------------------------------------------------------------------------------------------------------------------------------------------------------------------------------------------------------------------------------------------------------------------------------------------------------------------------------------------------------------------------------------------

General Specifications

Immersed Length	12 to 40 ft (1, 2, or 3 assemblies)
Minimum Manhole Diameter	14 in.
Operating Temperature	50° to 225°F
Element Rating	6 to 60 kW
Watt Density	4.1 to 6.5 W/in. ²
Voltage	240 and 480 Vac, 3 Phase



Chromalox® MCC Control Center

Unitary Immersion Heater Systems

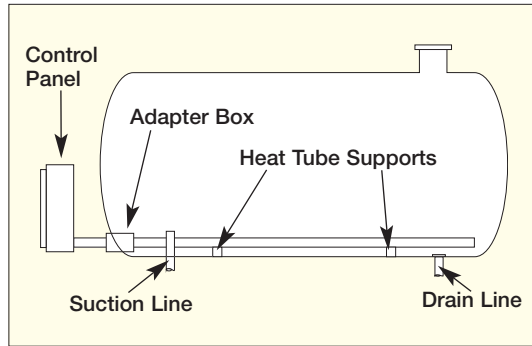

Applications

Chromalox® RSTO and RST unitary electric immersion systems provide low-watt-density heating for viscous materials such as asphalt, fuel oil, pitch and tar, liquid sugar, molasses, lube oils, linseed oil, and other heat-sensitive materials. They can be installed in above-ground tanks and in below-ground tanks with access to one tank end.

Model RSTO unitary electric immersion heater systems with open coil element (OCE) heaters are recommended for cramped locations because the open coil heating elements can be bent in a vertical plane on a 12-inch minimum radius and require only 3 feet for installation or removal. The RST model features metal-sheathed heating elements in place of the open coil elements. Both the RSTO and RST models are removable without draining the tank. A liquid-tight adapter box is provided for welding the heater assemblies to the tank header.

Construction

The heating elements are inserted into an assembly of 3-inch Schedule 40 NPS carbon steel or stainless steel pipes. The heaters are self-contained with built-in controls mounted in a weatherproof electrical enclosure.

There are two options for tank installation. The pipes can be welded into an adapter box for convenient field welding of the entire assembly to the header of a steel tank. Or the pipes can be welded into a Chromalox adapter flange or standard ANSI flange for mechanical integration with the tank. This allows for future removal and capping off the access port with a blind flange.

Features

Pre-engineered package	Unitary immersion heater systems are equipped with temperature and power controls, as well as safety cutouts
Economical	Ready for use once attached to the tank with no further operator attention required
Minimal maintenance	Heavy construction design; ideal for applications involving blast cleaning or routine tank cleanout
Weatherproof	Weatherproof control panel protects contactors fusing and heater terminations

General Specifications

Immersed Length	15 to 26 ft
Operating Temperature	50° to 400°F
Hold Temperature	175° to 350°F
Element Rating	15 to 72 kW
Watt Density	3 W/in. ²
Voltage	240 and 480 Vac, 3 Phase

Chromalox®

PRECISION HEAT AND CONTROL

Chromalox, Inc.
103 Gamma Drive
Pittsburgh, PA 15238
USA
Phone: (412) 967-3800
Fax: (412) 967-5148
email: sales@chromalox.com
www.chromalox.com

Chromalox-UK.
Eltron House
20-28 Whitehorse Road
Croydon, Surrey, CR9 2NA, UK
Tel: +44 (0)20 8665 8900
Fax: +44 (0)20 8689 0571
email: uksales@chromalox.com
www.chromalox.co.uk

Chromalox-France
Route de Château-Thierry
Noyant et Aconin
F-02203 SOISSONS Cedex, France
Tel: +33 (0)3 23 74 39 39
Fax: +33 (0)3 23 74 39 00
email: etirexchromalox@wanadoo.fr
www.chromalox.fr

Chromalox-China
Chromalox (Shanghai) Precision Heat and Control Co., Ltd.
Suite A2, 4th Floor, Fenggu Building
88 Taigu Road
Waigaoqia Free Trade Zone
Shanghai 200131
People's Republic of China
Tel: 011-86-21-5866-8802
Fax: 011-86-21-5866-8803
email: sales@chromalox.com
www.chromalox.cn