

1604

Temperature Controller



Issue date
May 2000

USER'S MANUAL

CONTENTS

MOUNTING REQUIREMENTS	1
OUTLINE AND CUT OUT DIMENSIONS	2
CONNECTION DIAGRAMS	3
PRELIMINARY HARDWARE SETTINGS	9
CONFIGURATION PROCEDURE	10
OPERATIVE MODE	18
Display function	18
Indicators	18
Pushbutton function during operating mode	19
Enable/disable the control output	20
SP/SP2 selection	20
OUT 1 failure detection function	20
Direct access to the set point	20
Manual function	21
Serial link	21
Lamp test	22
SMART function	22
OPERATIVE PARAMETERS	23
ERROR MESSAGES	26
GENERAL INFORMATIONS	28
MAINTENANCE	32
DEFAULT PARAMETERS	A.1

Model identification

Model

1604 1/16 DIN Temperature Controller

Code Output 1 - Heat or Cool

1 Relay, 3 Amps at 250 Vac (Resistive)

6 SSR Drive, 14 Vdc at 20 mA

Code Output 2 - Alarm

1 Relay, 2 Amp at 250 VAC (Resistive load)

Code

0 None

1 Out #3, 2 Amps at 250 V AC (Resistive load)

2 Heater Break Down input, Out #3

3 RS 485 Digital communications, Out #3

4 RS 485 Digital comm., Heater Break Down input, Out #3

Code Instrument Power

3 100 - 240 Vac

5 24 Vac/dc

Code

0 Add to complete model number

1601

6

1

0

3

0

Typical Model Number

MOUNTING REQUIREMENTS

Select a location, for instrument mounting, where minimum vibrations are present and the ambient temperature is within 0 and 50 °C (32 and 122°F). The instrument can be mounted on a panel up to 15 mm thick with a square cutout of 45 x 45 mm. For outline and cutout dimensions refer to Fig. 2. The surface texture of the panel must be better than 6,3 μm .

The instrument is shipped with rubber panel gasket (50 to 60 Sh).

To assure the IP65 and NEMA 4 protection, insert the panel gasket between the instrument and the panel as show in fig. 1.

While holding the instrument against the panel proceed as follows:

- 1) insert the gasket in the instrument case;
- 2) insert the instrument in the panel cutout;
- 3) pushing the instrument against the panel, insert the mounting bracket;
- 4) with a screwdriver, turn the screws with a torque between 0.3 and 0.4 Nm.

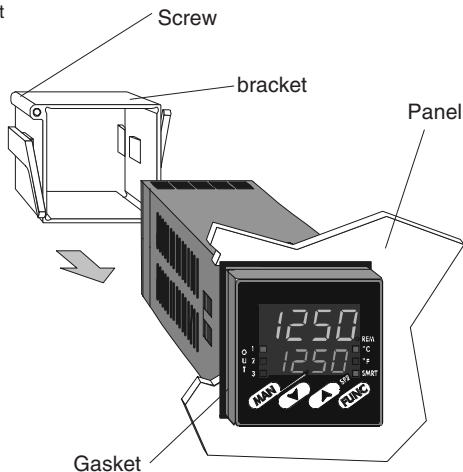

Fig. 1

OUTLINE AND CUT OUT DIMENSIONS

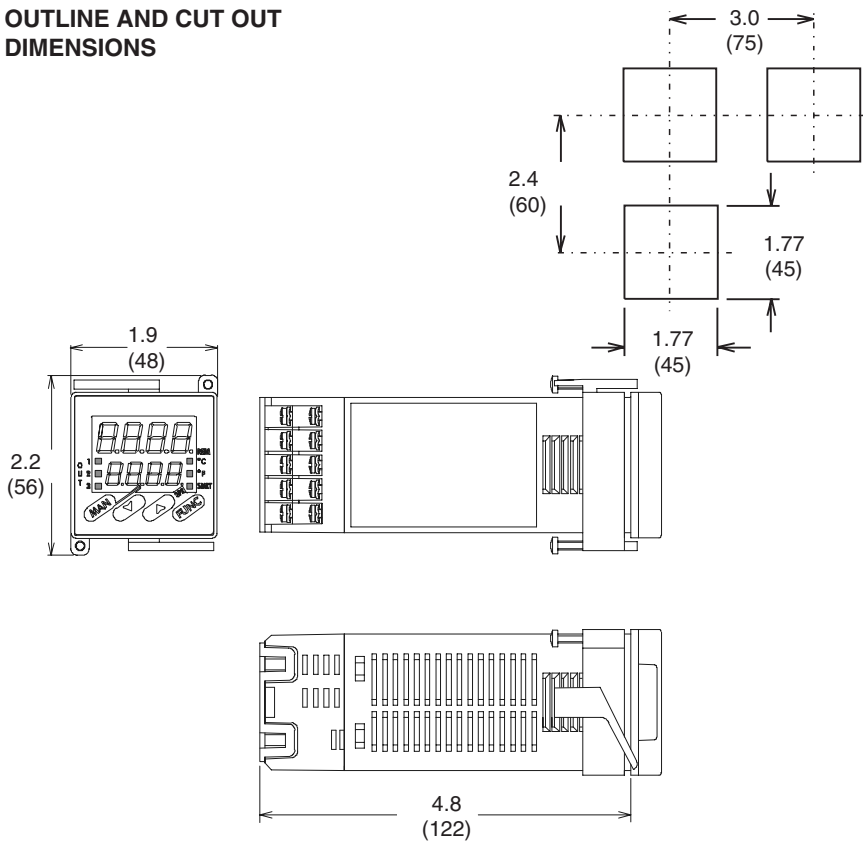

Fig. 2

OUTLINE AND CUT-OUT DIMENSIONS

CONNECTION DIAGRAMS

Connections are to be made with the instrument housing installed in its proper location.

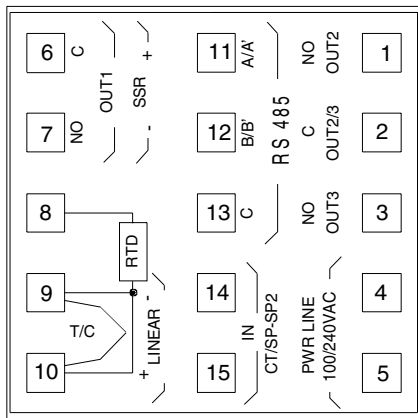

Fig. 3 REAR TERMINAL BLOCK

A) MEASURING INPUTS

NOTE: Any external component (like zener barriers etc.) connected between sensor and input terminals may cause errors in measurement due to excessive and/or not balanced line resistance or possible leakage currents.

TC INPUT

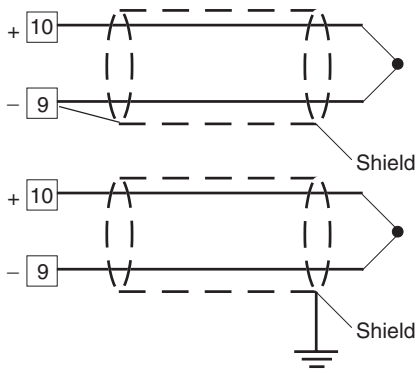

Fig. 4 THERMOCOUPLE INPUT WIRING

NOTE:

- 1) Don't run input wires together with power cables.
- 2) For TC wiring use proper compensating cable preferable shielded.
- 3) When a shielded cable is used, it should be connected at one point only.

RTD INPUT

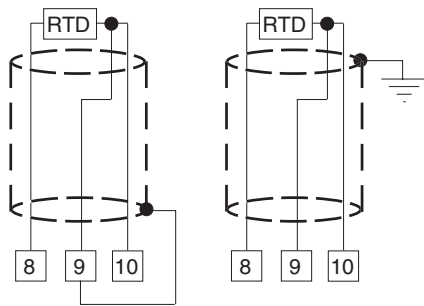

Fig. 5 RTD INPUT WIRING

NOTE:

- 1) Don't run input wires together with power cables.
- 2) Pay attention to the line resistance; a high line resistance may cause measurement errors.
- 3) When shielded cable is used, it should be grounded at one side only to avoid ground loop currents.
- 4) The resistance of the 3 wires must be the same.

LINEAR INPUT

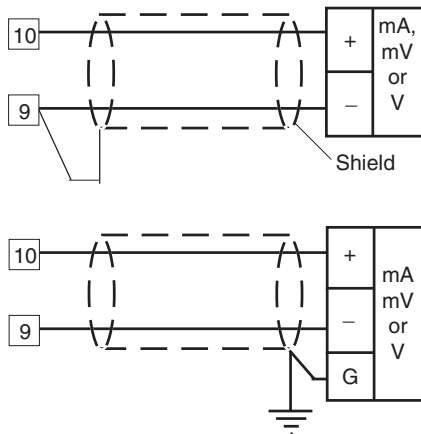

Fig. 6 mA, mV AND V INPUTS WIRING

NOTE:

- 1) Don't run input wires together with power cables.
- 2) Pay attention to the line resistance; a high line resistance may cause measurement errors.
- 3) When shielded cable is used, it should be grounded at one side only to avoid ground loop currents.
- 4) The input impedance is equal to:
 - < 5 Ω for 20 mA input
 - > 1 M Ω for 60 mV input
 - > 200 k Ω for 5 V input
 - > 400 k Ω for 10 V input

B.1) LOGIC INPUT

This instrument can use the input "IN CT/SP-SP2" (connections 14 and 15) as current transformer input or logic input.

Safety note:

- 1) Do not run logic input wiring together with power cables.
- 2) Use an external dry contact capable of switching 0.5 mA, 5 V DC.
- 3) The instrument needs 100 ms to recognize a contact status variation.
- 4) The logic inputs are **NOT** isolated by the measuring input.
- 5) This feature excludes the current transformer input.

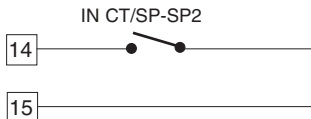

Fig. 7 - LOGIC INPUT WIRING

When the logic input is selected, it is used to switch, by an external contact, from main set point to second set point and viceversa.

logic input	op. set point
open	SP
close	SP2

B.2) CURRENT TRANSFORMER INPUT

This instrument can use the input "IN CT/SP-SP2" (connections 14 and 15) as current transformer input or logic input.

Safety note:

- 1) Do not run current transformer input wiring together with AC power cables.
- 2) The minimum active period to perform this measurement is equal to 400 ms.
- 3) This feature excludes the logic input function.
- 4) The input impedance is equal to 10 Ω .

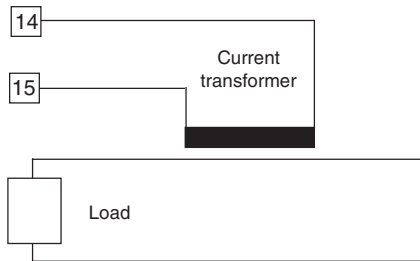

Fig. 8 - CURRENT TRANSFORMER INPUT WIRING

This input allows to measure and display the current running in the load driven by the OUTPUT1 during the ON and OFF period of the OUT 1 cycle time. By this feature it is also available the "OUT 1 failure detection" function (see page 20).

C) RELAY OUTPUTS

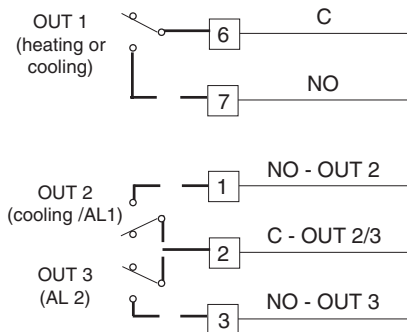

Fig. 9 RELAY OUTPUTS WIRING

The contact rating of the OUT 1 is 3A/250V AC on resistive load.

The contact rating of the OUT 2 and 3 is 2A/250V on AC resistive load.

The number of operations is 1×10^5 at specified rating.

- NOTES**
- 1) To avoid electrical shock, connect power line at the end of the wiring procedure.
 - 2) For power connections use No 16 AWG or larger wires rated for at last 75 °C.
 - 3) Use copper conductors only.
 - 4) Don't run input wires together with power cables.

All relay contacts are protected by varistor against inductive load with inductive component up to 0.5 A.

The following recommendations avoid serious problems which may occur, when using relay output for driving inductive loads.

INDUCTIVE LOADS

High voltage transients may occur switching inductive loads.

Through the internal contacts these transients may introduce disturbances which can affect the performance of the instrument.

For all the outputs, the internal protection (varistor) assures a correct protection up to 0.5 A of inductive component.

The same problem may occur when a switch is used in series with the internal contacts as shown in Fig. 10.

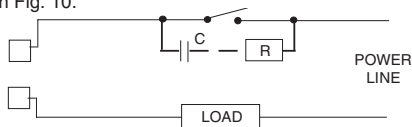

Fig. 10 EXTERNAL SWITCH IN SERIES WITH THE INTERNAL CONTACT

In this case it is recommended to install an additional RC network across the external contact as show in Fig. 10

The value of capacitor (C) and resistor (R) are shown in the following table.

LOAD (mA)	C (μF)	R (Ω)	P. (W)	OPERATING VOLTAGE
<40 mA	0.047	100	1/2	260 V AC
<150 mA	0.1	22	2	260 V AC
<0.5 A	0.33	47	2	260 V AC

The cable involved in relay output wiring must be as far away as possible from input or communication cables.

VOLTAGE OUTPUTS FOR SSR DRIVE

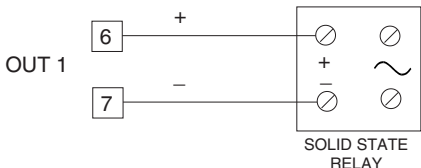

Fig. 11 SSR DRIVE OUTPUT WIRING

It is a time proportioning output.

Logic level 0: $V_{out} < 0.5$ V DC.

Logic level 1:

- 14 V \pm 20 % @ 20 mA

- 24 V \pm 20 % @ 1 mA.

Maximum current = 20 mA.

NOTE: This output is not isolated. A double or reinforced isolation between instrument output and power supply must be assured by the external solid state relay.

SERIAL INTERFACE

RS-485 interface allows to connect up to 30 devices with one remote master unit.

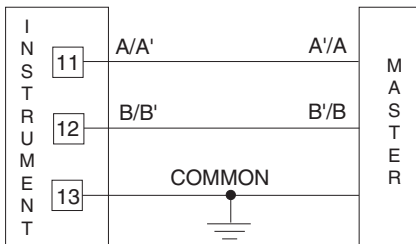

Fig. 12 - RS-485 WIRING

The cable length must not exceed 1.5 km at 9600 BAUD.

- NOTE:** 1) This is an RS485 isolated interface.
- 2) The following report describes the signal sense of the voltage appearing across the interconnection cable as defined by EIA for RS-485.
- The "A" terminal of the generator shall be negative with respect to the "B" terminal for a binary 1 (MARK or OFF) state.
 - The "A" terminal of the generator shall be positive with respect to the "B" terminal for a binary 0 (SPACE or ON)

D) POWER LINE WIRING

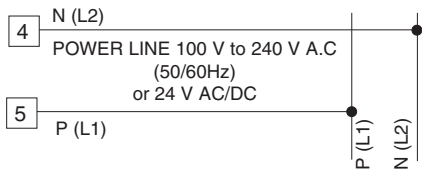

Fig. 13 POWER LINE WIRING

NOTES:

- 1) Before connecting the instrument to the power line, make sure that line voltage corresponds to the description on the identification label.
- 2) To avoid electrical shock, connect power line at the end of the wiring procedure.
- 3) For supply connections use No 16 AWG or larger wires rated for at last 75 °C.
- 4) Use copper conductors only.
- 5) Don't run input wires together with power cables.
- 6) For 24 V DC the polarity is a do not care condition.
- 7) The power supply input is **NOT** fuse protected.

Please, provide it externally.

Power supply	Type	Current	Voltage
24 V AC/DC	T	500 mA	250 V
100/240 V AC	T	125 mA	250 V

When fuse is damaged, it is advisable to verify the power supply circuit, so that it is necessary to send back the instrument to your supplier.

- 8) The safety requirements for Permanently Connected Equipment say:
 - a switch or circuit-breaker shall be included in the building installation;
 - It shall be in close proximity to the equipment

and within easy reach of the operator;
- it shall be marked as the disconnecting device for the equipment.

NOTE: a single switch or circuit-breaker can drive more than one instrument.

- 9) When a neutral line is present, connect it to terminal 4

PRELIMINARY HARDWARE SETTINGS

- 1) Remove the instrument from its case.
- 2) It is necessary to set J106 according to the desired input type as shown in the following figure.

INPUT TYPE	J106				
	1-2	3-4	5-6	7-8	9-10
TC-RTD	open	close	open	open	open
60 mV	open	close	open	open	open
5 V	close	open	close	open	open
10 V	open	open	close	open	open
20 mA	open	open	open	close	close

NOTE : the not used jumper can be positioned on pin 7-9

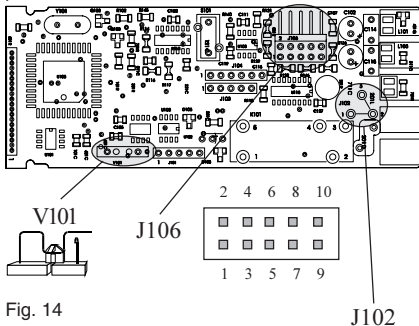

Fig. 14

- 3) Select the output 1 contact : NO (standard) or NC by setting J102 according to the following table:

Contact	NO (standard)	NC
J102	1 - 2	2 - 3

OPEN INPUT CIRCUIT

This instrument is able to identify the open circuit for TC and RTD inputs.

The open input circuit condition for RTD input is shown by an "overrange" indication. For TC input, it is possible to select overrange indication (standard) or underrange indication setting the CH101 and SH101 according to the following table:

Overrange (STD)	CH101 = close	SH101 = open
Underrange	CH101 = open	SH101 = close

Both pads are located on the soldering side of the CPU card

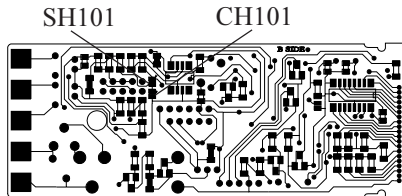

Fig. 15

SELECTION OF THE "IN CT/SP-SP2" FUNCTION

This instrument can use the input "IN CT/SP-SP2" (connections 14 and 15) as current transformer input or a logic input.

The current transformer input allows to measure and display the current running in the load driven by the OUTPUT1 during the ON and OFF period of the OUT 1 cycle time. By this feature it is also available the "OUT 1 failure detection" function (see page 20). The logic input is used to switch, by an external contact, from main set point to second set point and viceversa.

To select the desired input type, set J504 as detailed in the figure shown below:

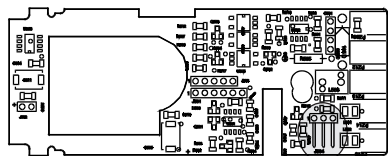

Current transformer input

J504



Logic input

Fig. 16

GENERAL NOTES for configuration.

- FUNC = This will memorize the new value of the selected parameter and go to the next parameter (increasing order).
- MAN = This will scroll back the parameters without memorization of the new value.
- ▲ = This will increase the value of the selected parameter
- ▼ = This will decrease the value of the selected parameter.

CONFIGURATION PROCEDURE

- 1) Remove the instrument from its case.
 - 2) Set the dip switch V101 to the open condition (see fig. 14).
 - 3) Re-insert the instrument.
 - 4) Switch on the instrument.
- The display will show CONF.

NOTE : If "CAL" indication is displayed, press immediately the ▲ pushbutton and return to the configuration procedure.

- 5) Push the FUNC pushbutton.

SER1 = Serial interface protocol

- OFF = No serial interface
Ero = Polling/selecting ERO
nbUS = Modbus
jbUS = Jbus

SER2 = Serial link device address

Not available when SER1 = OFF
From 1 to 95 for ERO protocol.
From 1 to 255 for all the other protocols.

NOTE: the electrical characteristic of the RS 485 serial interface will allow the connection of 31 devices maximum.

SEr3 = Baud rate for serial link

Not available when SEr1 = OFF

From 600 to 19200 baud.

NOTE: 19200 baud is shown on display as 19.20.

SEr4 = Byte format for serial link

Not available when SEr1 = OFF

7E = 7 bits + even parity (For ERO protocol only)

7O = 7 bits + odd parity (For ERO protocol only)

8E = 8 bits + even parity

8O = 8 bits + odd parity

8 = 8 bits no parity

P1 - Input type and standard range

0 = TC type L range 0 / +400.0°C

1 = TC type L range 0 / +900°C

2 = TC type J range -100.0 / +400.0°C

3 = TC type J range -100 / +1000°C

4 = TC type K range -100.0 / +400.0°C

5 = TC type K range -100 / +1370°C

6 = TC type N range -100 / +1400°C

7 = TC type R range 0 / +1760°C

8 = TC type S range 0 / +1760°C

9 = RTD type Pt 100 range -199.9 / +400.0°C

10 = RTD type Pt 100 range -200 / +800°C

11 = mV Linear range 0 / 60 mV

12 = mV Linear range 12 / 60 mV

13 = mA Linear range 0 / 20 mA

14 = mA Linear range 4 / 20 mA

15 = V Linear range 0 / 5 V

16 = V Linear range 1 / 5 V

17 = V Linear range 0 / 10 V

18 = V Linear range 2 / 10 V

19 = TC type L range 0 / +1650°F

20 = TC type J range -150 / +1830°F

21 = TC type K range -150 / +2500°F

22 = TC type N range -150 / +2550°F

23 = TC type R range 0 / +3200°F

24 = TC type S range 0 / +3200°F

25 = RTD type Pt 100 range -199.9 / +400.0°F

26 = RTD type Pt 100 range -330 / +1470°F

27 = TC type T range -199.9 / +400.0°C

28 = TC type T range -330 / +750°F

NOTE: selecting P1 = 0, 2, 4, 9, 25 or 27, the instrument set automatically P36 = FLtr. For all the remaining ranges it will set P36 = nOFL. If a different selection is desired, P36 may be modified.

P2 = Decimal point position

This parameter is available only when a linear input is selected (P1 = 11, 12, 13, 14, 15, 16, 17 or 18).

----. = No decimal figure.

---. = One decimal figure.

.. = Two decimal figures.

-. = Three decimal figures.

P3 = Initial scale value

For linear inputs it is programmable from -1999 to 4000.

For TC and RTD input it is programmable within the input range.

When this parameter is modified, rL parameter will be re-aligned to it.

P4 = Full scale value

For linear inputs it is programmable from -1999 to 4000.

For TC and RTD input it is programmable within the input range.

When this parameter is modified, rH parameter will be re-aligned to it.

The initial and full scale values determine the input span which is used by the PID algorithm, the SMART and the alarm functions.

NOTE: the minimum input span ($S = P4 - P3$), in absolute value, should be set as follows:

For linear inputs, $S \geq 100$ units.

For TC input with °C readout, $S \geq 300$ °C.

For TC input with °F readout, $S \geq 550$ °F.

For RTD input with °C readout, $S \geq 100$ °C.

For RTD input with °F readout, $S \geq 200$ °F.

P5 = Output 1 type

rEL = Relay [the cycle time (Cy1) will be forced to 15 s]

SSr = SSR [the cycle time (Cy1) will be forced to 4 s]

P6 = Output 1 action.

This parameter is skipped if P7 = 4

rEV = Reverse action (Heating action)

dir = Direct action (Cooling action)

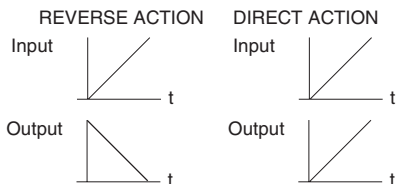

P7 = Output 2 function.

0 = output not used.

1 = it is used as alarm 1 output and the alarm 1 is programmed as process alarm.

2 = it is used as alarm 1 output and the alarm 1 is programmed as band alarm.

3 = it is used as alarm 1 output and the alarm 1 is programmed as deviation alarm.

4 = it is used as second control output (Cooling output).

NOTE: setting P7 = 4, the P6 parameter is forced to "rEV".

P8 = Cooling media.

Available only when P7 = 4

Alr = Air is used as cooling media.

OIL = Oil is used as cooling media.

H2O = Direct water is used as cooling media.

Changing P8 parameter, the instrument forces the cycle time and relative cooling gain parameter to the default value related with the chosen cooling media

When P8 = Alr - Cy2 = 10 s and rC = 1.00

P8 = OIL - Cy2 = 4 s and rC = 0.80

P8 = H2O - Cy2 = 2 and rC = 0.40

P9 = Alarm 1 operating mode

Available only when P7 is equal to 1, 2 or 3.

H.A. = High alarm (outside for band alarm) with automatic reset.

L.A. = Low alarm (inside for band alarm) with automatic reset.

H.L. = High alarm (outside band) with manual reset (latched).

L.L. = low alarm (inside band) with manual reset (latched).

P10 = Option feature (see also "Display function" and "OUT 1 failure detection")

OFF = No option

SP2 = Digital input for SP / SP2 selection.

n.O. = Set P10 to n.O. when the load is

energized during the ON status of the instrument output (relay energized or SSR output status 1).

n.C. = Set P10 to n.C. when the load is energized during the OFF status of the instrument output (relay de-energized or SSR output status 0).

P11 = Current transformer range

This parameter is present only if P10 is different from OFF or SP2 and it is programmable from 10 to 100 A.

P12 = Output 3 function

0 = Output not used for alarm 2.

1 = it is used as alarm 2 output and the alarm 2 is programmed as process alarm.

2 = it is used as alarm 2 output and the alarm 2 is programmed as band alarm.

3 = it is used as alarm 2 output and the alarm 2 is programmed as deviation alarm.

NOTE : The output 3 relay operates as a logic OR between the alarm 2 and the "OUT 1 failure detection" function.

P13 = Alarm 2 operating mode & OUT 1 failure detection reset

Available only when P12 is different from 0 or P10 is equal to n.O or n.C.

H.A. = High alarm (outside for band alarm) with automatic reset.

L.A. = Low alarm (inside for band alarm) with automatic reset.

H.L. = High alarm (outside band) with manual reset (latched).

L.L. = Low alarm (inside band) with manual reset (latched).

NOTE:The "Out 1 failure detection" function assumes only the selected reset type (manual or automatic).

P14 = Programmability of the alarm 2 threshold and hysteresis values

Available only when P12 is different from 0.

OPrt = Alarm 2 threshold and hysteresis are programmable in the operating mode.

COnF = Alarm 3 threshold and hysteresis are programmable in configuration mode.

P15 = Alarm 2 threshold value

Available only when P12 is different from 0 and P14 is equal to "COnF".

Range: For process alarm - within the range limits.
For band alarm - from 0 to 500 units.
For deviation alarm - from -500 to 500 units.

P16 = Alarm 2 hysteresis value

Available only when P12 is different from 0 and P14 is equal to "COnF".

Range: from 0.1% to 10.0 % of the range selected with P3 and P4 parameters or 1 LSD.

P17 = Threshold of the "Soft Start" function.

Threshold value in eng. units to initiate the "Soft start" function (output power limiting) at start up.

Range : within the readout span.

NOTE: This threshold value will not be taken into account when tOL = InF.

P18 = Safety lock

0 = No parameter protection. The device is always in unlock condition and all parameters can be modified.

1 = The device is always in lock condition and no parameter (exception made for the set points [SP/SP2] and alarm manual reset) can be modified (for SMART status see P27).

From 2 to 4999 = This combination number is a secret value to be used, in run time (see nnn parameter) to put device in lock/unlock condition.

For SP, SP2 and manual reset of the alarms, the lock/unlock condition has no effect (for SMART status see P27).

From 5000 to 9999 = This combination number is a secret value to be used, in run time (see nnn parameter) to put device in lock/unlock condition.

For SP, SP2, manual reset of the alarm, AL1, AL2, Hbd and SCA, the lock/unlock condition has no effect (for SMART status see P27).

NOTE: when safety lock is selected, the secret value can not be displayed again and the display will show 0, 1, Sft.A (when P18 is encompassed between 2 and 4999) or Sft.b (when P18 is encompassed between 5000 and 9999)

The configuration procedure is completed and the instrument shows " " on both displays. If no other setting is necessary, push the FUNC pushbutton, the display returns to show "CONF". Otherwise access to the advanced configuration parameter proceeding as follows:

- 1) using ▲ and ▼ pushbutton to set the 234 code on the display.
- 2) push the FUNC pushbutton.

P19 = Alarm 1 action

Available only when P7 is different from 0 or 4.

dir = direct action (relay energized in alarm condition)

rEV = reverse action (relay deenergized in alarm condition)

P20 = alarm 1 stand-by function

Available only when P7 is different from 0 or 4.

OFF = stand-by function disabled

On = stand-by function enabled

NOTE: If the alarm is programmed as band or deviation alarm, this function masks the alarm condition after a set point change or at the instrument start-up until the process variable reaches the alarm threshold plus or minus hysteresis. If the alarm is programmed as a process alarm, this function masks the alarm condition at instrument start-up until process variable reaches the alarm threshold plus or minus hysteresis.

P21 = Action of the alarm 2 and "OUT 1 failure detection" function

Available only when P12 is different from 0 or P10 is equal to "n.O" or "n.C".

dir = direct action (relay energized in alarm condition)

rEV = reverse action (relay de-energized in alarm condition)

P22 = Alarm 2 stand-by function

Available only when P12 is different from 0.

OFF = Stand-by function disabled

On = Stand-by function enabled

NOTE: for more details on stand-by function, see P20 parameter.

P23 = OFFSET adjustment added to the measured value

This parameter allows to set a constant OFFSET throughout the readout range.

It is skipped for linear inputs

- For readout ranges with decimal figure, P23 is programmable from -19.9 to 19.9.
- For readout ranges without decimal figure, P23 is programmable from -199 to 199.

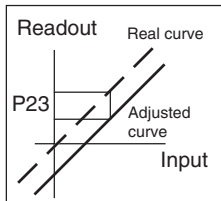

P24 = NOT AVAILABLE

P25 = Displayable protected parameters

This parameter is skipped when P18 = 0.

OFF = Protected parameters cannot be displayed.

On = Protected parameter can be displayed.

P26 = MANUAL function

OFF = manual function is disabled

On = manual function can be enabled/disabled by MAN pushbutton.

P27 = SMART function

0 = SMART function disabled.

1 = SMART function in NOT protected by safety lock.

2 = SMART function is under safety lock protection.

P28 = Relative cooling gain calculated by SMART function.

This parameter is present only if P7 = 4 and P27 is different from 0.

OFF = SMART algorithm does not calculate the rC parameter value

On = SMART algorithm calculates the rC parameter value.

P29 = Maximum value of the proportional band calculated by the SMART algorithm.

This parameter is present only if P27 is different from 0.

This parameter is programmable from P30 or P31 value to 100.0 %.

P30 = Minimum value of the proportional band calculated by the SMART algorithm when the instrument has two control outputs.

This parameter is available only when P7 = 4 and P27 is different from 0.

It is programmable from 1.5% to P29 value.

P31 = Minimum value of the proportional band calculated by the SMART algorithm when the instrument has one control output.

This parameter is available only when P7 is different from 4 and P27 is different from 0.

It is programmable from 1.0 % to P29 value.

P32 = Minimum value of the integral time calculated by the SMART algorithm.

This parameter is present only if P27 is different from 0.

It is programmable from 1 second (00.01) to 2 minutes (02.00).

P33 = Device status at instrument start up.

This parameter is skipped when P26 = OFF.
0 = the instrument starts in AUTO mode.

1 = It starts in the same way it was left prior to power shut down.

P34 = NOT AVAILABLE

P35 = Timeout selection

This parameter allows to set the time duration of the timeout for parameter setting used by the instrument during the operating mode.

tn. 10 = 10 seconds

tn 30 = 30 seconds

P36 = Digital filter on the measured value

It is possible to apply to the displayed value a digital filter of the first order with a time constant equal to :

- 4 s for TC and RTD inputs

- 2 s for linear inputs

noFL. = no filter

FLtr = filter enabled

P37 = Conditions for output safety value

0 = No safety value (see "Error Messages" Chapter)

1 = Safety value applied when overrange or underrange condition is detected.

2 = Safety value applied when overrange condition is detected.

3 = Safety value applied when underrange condition is detected.

P38 = Output safety value

This parameter is skipped when P37 = 0

This value can be set

- from 0 to 100 % when P7 is different from 4

- from -100 % to 100 % when P7 is equal to 4

P39 = Extension of the anti-reset wind up

Range: from -30 to +30 % of the proportional band.

NOTE: a positive value increases the high limit of the anti-reset-wind up (over set point) while a negative value decreases the low limit of the anti-reset-wind up (under set point).

P40 = Control action type

Pid - the instrument operates with a PID algorithm.

Pi - the instrument operates with a PI algorithm.

P41 = Set point indication

Fn.SP = during operative mode, when the instrument performs a ramp, it will show the final set point value.

OP.SP = during operative mode, when the instrument performs a ramp, it will show the operative set point.

P42 = Operative set point alignment at instrument start up

0 = At start up, the operative set point will be aligned to SP or SP2 according to the digital input status.

1 = At start up, the operative set point will be aligned to the measured value, the selected set point value will be reached by the programmed ramp (see Grd1 and Grd2 operative parameters).

NOTE: if the instrument detects an out of range or an error condition on the measured value it will ever operate as described for P42 = 0.

The configuration procedure is terminated and the display returns to show "CONF".

OPERATIVE MODE

- 1) Remove the instrument from its case.
- 2) Set the internal dip switch V101 in closed condition
- 3) Re-insert the instrument.
- 4) Switch on the instrument.

DISPLAY FUNCTION

The upper display shows the measured value while the lower display shows the programmed set point value (we define the above condition as "normal display mode").

Note: When the rate of change (Grd1, Grd2) is utilized, the displayed set point value may be different from the operating set point.

It is possible to change the information on the lower display as follows:

- By pushing the FUNC pushbutton within 3s to 10s. The lower display will show "A." followed by the current consumed by the load (driven by the OUT 1) when the load is in ON condition (see also "OUT 1 failure detection").
- Push FUNC pushbutton again, the lower display will show "b." followed by the leakage current running in the load (driven by the OUT 1) when the load is in OFF condition (see also "OUT 1 failure detection").
- Push FUNC pushbutton again, the lower display will show "H." followed by OUT 1 power value (from 0 to 100%).
- Push FUNC pushbutton again, the lower display will show "C." followed by OUT 2 power value (from 0 to 100%).
- Push FUNC pushbutton again. The display will return in "Normal Display Mode".

NOTE: The "A", "b" and "C" informations will be displayed only if the relative function has been previously configured.

When no pushbutton are pressed during the time out (see P35), the display will automatically return in "Normal Display Mode".

In order to keep the desired information continuously on the lower display, depress ▲ or ▼ push-button to remove the timeout.

When return in "Normal Display Mode" is desired, push FUNC push-button again.

INDICATORS

- °C Lit when the process variable is shown in Celsius degree.
- °F Lit when the process variable is shown in Fahrenheit degree.
- SMRT Flashing when the first part of the SMART algorithm is active.
Lit when the second part of the SMART algorithm is active.
- OUT1 Lit when OUT 1 is ON.
- OUT2 Lit when OUT 2 is ON or alarm 1 is in the alarm state.
- OUT3 Lit when the alarm 2 is in the alarm state.
Flashing with slow rate when the OUT 1 failure detection is in the alarm state.
Flashing with high rate when the OUT 1 failure detection and alarm 2 are in the alarm state.

Other functions are shown by decimal points:

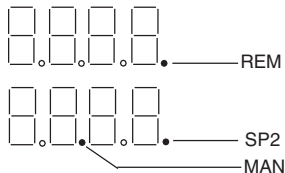

REM = Flashing, when the instrument is controlled via serial link.

SP2 = Flashing at slow rate when SP2 is used.
Flashing at fast rate when a set point from serial link is used.
MAN= Flashing at slow rate, when the instrument is in MANUAL mode.

Pushbutton functionality during operating mode.

- FUNC = when the instrument is in "normal display mode"
- 1) with a brief pressure (<3s) it starts the parameter modification procedure.
 - 2) with a pressure within 3s to 10s it changes the indication on the lower display (see "display function").
 - 3) with a pressure longer than 10s it enables the lamp test (see "Lamp Test" paragraph).
- During parameter modification, it allows to memorize the new value of the selected parameter and go to the next parameter (increasing order).
- MAN = when the instrument is in "normal display mode", pushing MAN pushbutton for more than 1 s, it is possible to enable or disable the manual function.
- During parameter modification, it allows to scroll back the parameters without memorizing the new setting.
- ▲ = During parameter modification, it allows to increase the value of the selected parameter
- During MANUAL mode, it allows to increase the output value.
- ▼ = During parameter modification, it allows to decrease the value of the selected parameter

During MANUAL mode, it allows to decrease the output value.

- ▲+FUNC = when device is in normal display mode, they allow to enable/disable the control output (see "Enable/disable the control output" paragraph).
- ▲+MAN = During parameter modification they allow to jump to the maximum programmable value.
- ▼+MAN = During parameter modification they allow to jump to the minimum programmable value.

NOTE: a 10 or 30 seconds time out (see P 35) can be selected for parameter modification during run time mode.

If, during parameter modification, no pushbutton is depressed for more than 10 (30) seconds, the instrument goes automatically to the "normal display mode" and the eventual modification of the last parameter will be lost.

ENABLE/DISABLE THE CONTROL OUTPUT

When the instrument is in "normal display mode", by keeping depressed for more than 5s ▲ and FUNC pushbuttons, it is possible to disable the control outputs. In this open loop mode the device will function as an indicator, the lower display will show the word OFF and all control outputs will also be in the OFF state.

When the control outputs are disabled the alarms are also in non alarm condition.

The alarm outputs conditions depend on the alarm action type (see P19-P21).

Depress for more than 5s ▲ and FUNC pushbuttons to restore the control status.

The alarm stand-by function, if configured, will be activated as if it was at power up.

If a power down occurs when the control output is disabled, at intrument power up the control output will be automatically disabled.

SP - SP2 SELECTION

It is possible to select the operating set point (SP or SP2) only by an external contact (terminals 14 and 15).

This function excludes the "OUT 1 failure detection" function and the current transformer.

By setting P41, it is possible to display the final or the operative set point during a ramp execution.

OUT 1 FAILURE DETECTION FUNCTION

The device is capable (for the load driven by the OUT 1) to measure and display:

- the current running in the load when the load is energized;
- the leakage current, flowing through the load, when the load is de-energized.

If the P10 parameter has been correctly set, the instrument generates an alarm when:

- the current running in the load is lower than the "Hbd" parameter value (It shows a partial or total break down of the load, the break down of the actuator or a power down due to a protection or a fuse intervention);
- the leakage current is higher than the "SCA" parameter value (It shows a short circuit of the actuator).

The "Display function" paragraph describes how to show the two current values.

A fault condition is shown by OUT 3 LED flashing and by OUT 3 relay status.

If the ON or OFF period is lower than 400 ms the relative measurement couldn't be performed and the instrument will show flashing the last measured value.

DIRECT ACCESS TO THE SET POINT

When the device is in AUTO mode and in "Normal Display Mode", it is possible to access directly to set point modification (SP or SP2).

Pushing ▲ or ▼ for more than 2 s, the set point will begin changing.

The new set point value becomes operative since no pushbutton has been depressed at the end of 2 s timeout.

MANUAL FUNCTION

The MANUAL mode function can be accessed (only if enabled by P26=On) by depressing the MAN pushbutton for more than 1 sec.

The command is accepted and executed only if the display is in "Normal Display Mode".

When in MANUAL mode the LED's MAN annunciator will light up while the lower display shows the power output values.

The value of OUT 1 is shown in the two most significant digit field while the value of OUT 2 (if present) is shown in the two less significant digit field.

The decimal point between the two values will be flashing to indicate instrument in manual mode.

Note: A graphic symbol "   " is used for

OUT1 = 100

A graphic symbol "   " is used for

OUT2 = 100

The power output can be modified by using ▲ and ▼ pushbuttons.

By depressing, for more than 1 second, MAN pushbutton the device returns in AUTO mode.

The transfer from AUTO to MANUAL and viceversa is bumpless (this function is not provided if integral action is excluded).

If transfer from AUTO to MANUAL is performed during the first part of SMART algorithm (TUNE) when returning in AUTO the device will be forced automatically in the second part of the SMART algorithm (ADAPTIVE).

At power up the device will be in the AUTO mode or as it was left prior to power shut down depending on P33 configuration selection.

Note: When start up occurs in Manual mode the power output (OUT1 - OUT2) is set to 0.

SERIAL LINK

The device can be connected to a host computer by a serial link.

The host can put the device in LOCAL (functions and parameters are controlled via keyboard) or in REMOTE (functions and parameters are controlled via serial link).

The REMOTE status is signalled by the decimal point (labelled REM) at the right hand of the LSD of the upper display.

This instrument allows to modify the operative and configuration parameters, via serial link.

The necessary conditions to implement this function are the following:

- 1) Serial parameters from SER1 to SER4 should be properly configured using the standard front keyboard procedure
- 2) Device must be in the OPERATING mode

During the downloading configuration the device goes in open loop with all output in OFF state. At the end of configuration procedure, the device performs an automatic reset and then returns to close loop control.

LAMP TEST

When it is desired to verify the display efficiency, push FUNC pushbutton for more than 10 s. The instrument will turn ON, with a 50 % duty cycle, all the LEDs of the display (we define this function "LAMP TEST").

No time out is applied to the LAMP TEST.

When it is desired to come back to the normal display mode, push FUNC pushbutton again.

During the LAMP TEST the instrument continues to control the process but no keyboard functions are available (exception made for the FUNC pushbutton).

SMART function

It is used to automatically optimize the control action.

To enable the SMART function, push the FUNC pushbutton until "SnrT" parameter is shown. Pushing ▲ or ▼ set the display "On" and push the FUNC pushbutton.

The SMRT LED will turn on or flashing according to the algorithm selected.

When the smart function is enabled, it is possible to display but not to modify the control parameters.

To disable the SMART function, push the FUNC pushbutton again until "SnrT" parameter is shown. Pushing ▲ or ▼ set the display "OFF" and push the FUNC pushbutton.

The SMRT LED will turn off.

The instrument maintains the actual set of control parameters and it enables parameter modification.

- NOTES :**
- 1) When ON/OFF control is programmed (Pb=0), the SMART function is disabled.
 - 2) The SMART enabling/disabling can be protected by safety key (see P27).

OPERATIVE PARAMETERS

Push the FUNC pushbutton, the lower display will show the code while the upper display will show the value or the status (ON or OFF) of the selected parameter.

By ▲ or ▼ pushbutton it is possible to set the desired value or the desired status.

Pushing the FUNC pushbutton, the instrument memorizes the new value (or the new status) and goes to the next parameter.

Some of the following parameter may be skipped according to the instrument configuration.

Param. DESCRIPTION

SP	Set point (in eng. units). Range: from rL to rH. SP is operative when the logic input is open.
Snrt	SMART status. The On or OFF indication shows the actual status of the SMART function (enabled or disabled respectively). Set On to enable the SMART function. Set OFF to disable the SMART function.
n.rSt	Manual reset of the alarms. This parameter is skipped if none of the alarms has the manual reset function. Set On and push FUNC to reset the alarms.
SP2	Set point 2 (in eng. units). Range: from rL to rH. SP2 is operative when the logic input is closed.
nnn	Software key for parameter protection. This parameter is skipped if P18 = 0 or 1 On = the instrument is in LOCK condition OFF = the instrument is in UNLOCK condition

When it is desired to switch from LOCK to UNLOCK condition, set a value equal to P18 parameter.

When it is desired to switch from UNLOCK to LOCK condition, set a value different from P18 parameter.

AL1

Alarm 1 threshold

This parameter is available only if P 7 is equal to 1,2 or 3.

Ranges:

- Span limits for process alarm.
- From 0 to 500 units for band alarm.
- From -500 to 500 units for deviation alarm.

HSA1

Alarm 1 hysteresis

This parameter is available only if P 7 is equal to 1,2 or 3.

Range: From 0.1% to 10.0% of the input span or 1 LSD.

Note: If the hysteresis of a band alarm is larger than the alarm band, the instrument will use an hysteresis value equal to the programmed band minus 1 digit.

AL2

Alarm 2 threshold

This parameter is available only if P 12 is equal to 1,2 or 3 and P14 is equal to OPrt. For other details see AL1parameter.

HSA2

Alarm 2 hysteresis

This parameter is available only if P 12 is equal to 1,2 or 3 and P14 is equal to OPrt. For other details see HSA1parameter.

Pb

Proportional band

Range:

- from 1.0% to 100.0% of the input span for one control output.
 - from 1.5% to 100.0% of the input span for two control outputs.
- When Pb parameter is set to 0.0, the control action becomes ON-OFF.

	Note: When device is working with SMART algorithm the Pb value will be limited by P29, P30 and P31 parameters.	rC	Relative Cooling gain. This parameter is available only when device is configured with two control outputs and Pb is different from zero. Range: from 0.20 to 1.00
HyS	Hysteresis for ON/OFF control action This parameter is available only when Pb=0. Range: from 0.1% to 10.0% of the input span.		Note: When the device is working with SMART algorithm and P28 is set to On then the RCG value is limited in accordance with the selected type of cooling media: - from 0.85 to 1.00 when P8 = Alr - from 0.80 to 0.90 when P8 = OIL - from 0.30 to 0.60 when P8 = H2O
ti	Integral time This parameter is skipped if Pb=0 (ON/OFF action). Range: from 00.01 to 20.00 [mm.ss]. Above this value the display blanks and integral action is excluded	OLAP	Dead band/Overlap between H/C outputs. This parameter is available only when device is configured with two control outputs and Pb is different from zero. Range: from -20 to 50 % of the proportional band. A negative OLAP value shows a dead band while a positive value shows an overlap.
td	Derivative time This parameter is skipped if Pb=0 (ON/OFF action) or P40 = Pi. Range:From 00.00 to 10.00 mm.ss. Notes: When device is working with SMART algorithm the td value will be equal to a quarter of Ti value.	rL	Set point low limit Range: from initial scale value (P3) to rH.
IP	Integral pre-load. This parameter is skipped if Pb=0 (ON/OFF action). For one control output, it is programmable from 0 to 100 % of the output span. For two control outputs it is programmable from -100% (100 % cooling) to 100 % (100 % heating).	rH	Set point high limit Range:from rL to full scale value (P4) Note: When P4 has been modified, rH will be realigned to it
Cy1	Output 1 cycle time Range:From 1 to 200 s.	Grd1	Ramp applied to an increasing set point change Range: from 1 to 100 digits per minute. Above this value the display shows "Inf" meaning that the transfer will be done as a step change.
Cy2	Output 2 cycle time This parameter is available only if P 7 is equal to 4. Range:From 1 to 200 s.	Grd2	Ramp applied to a decreasing set point changes For other details see Grd1 parameter.

OLH	<p>Output high limit Range: - From 0 to 100 % when device is configured with one control output. - From -100 to 100% when device is configured with two control outputs.</p>	rnP	<p>Control output maximum rate of rise This parameter is available only when Pb is different from zero It is programmable from 1% to 25% of the output per second. Above the 25%/s, the display will show "InF" meaning that no ramp is imposed.</p>
tOL	<p>Time duration of the output power limiter (soft start) Range: from 1 to 540 min. Above this value the display shows "InF" meaning that the limiting action is always on Note: The tOL can be modified but the new value will become operative only at the next instrument start up.</p>		
Hbd	<p>Threshold value for out 1 break down alarm This parameter is available only when P10 is equal to N.O. or N.C. Range: From 0 to P11 value (in ampere). Notes: The threshold resolution will be equal to 0.1 A for range up to 20 A and 1 A for range up to 100 A. The hysteresis of this alarm is fixed to 1% of fsv</p>		
SCA	<p>Threshold value for OUT 1 short circuit alarm. This parameter is available only when P10 is equal to N.O. or N.C. Range: From 0 to P11 value (in ampere). Notes: The threshold resolution will be equal to 0.1 A for range up to 20 A and 1 A for range up to 100 A. The hysteresis of this alarm is fixed to 1% of fsv</p>		

ERROR MESSAGES

OVERRANGE, UNDERRANGE AND SENSOR LEADS BREAK INDICATIONS

The device is capable to detect a fault on the process variable (OVERRANGE or UNDERRANGE or SENSOR LEADS BREAK).

When the process variable exceeds the span limits set by configuration parameter P 1 an OVERRANGE condition will be shown on display as show in the following figure:



An UNDERRANGE condition will be shown on display as show in the following figure:



When P37 is equal to 0, the following conditions may occur:

- The instrument is set for one output only and if an OVERRANGE is detected, the output turns OFF (if reverse action) or ON (if direct action).
- The instrument is set for heating/cooling action and an OVERRANGE is detected, "rEV" output turns OFF and "dir" output turns ON.
- The instrument is set for one output only and if an UNDERRANGE is detected, the output turns ON (if reverse action) or OFF (if direct action).
- The instrument is set for heating/cooling action and an UNDERRANGE is detected, "rEV" output turns ON and "dir" output turns OFF.

When P37 is different from zero and an out of range condition is detected, the instrument operates in accordance with P37 and P38 parameters.

The sensor leads break can be signalled as:

- for TC/mV input : OVERRANGE or UNDERRANGE selected by a solder jumper
- for RTD input : OVERRANGE
- for mA/V input : UNDERRANGE

Note: On the mA/V input the leads break can be detected only when the range selected has a zero elevation (4/20 mA or 1/5 V or 2/10 V)
On RTD input a special test is provided to signal OVERRANGE when input resistance is less than 15 ohm (Short circuit sensor detection).

ERROR MESSAGES

The instrument performs self-diagnostic algorithm. When an error is detected, the instrument shows on the lower display the "Err" indication while the upper display shows the code of the detected error.

ERROR LIST

SEr	Serial interface parameter error.
100	Write EEPROM error.
150	CPU error.
200	Tentative to write on protected memory.

201 - 2xx	Configuration parameter error. The two less significant digits shown the number of the wrong parameter (ex. 209 Err shows an Error on P9 parameter)
301	RTD input calibration error
305	TC/mV input calibration error
307	RJ input calibration error
310	CT input calibration error
311	Error on 20 mA input calibration
312	Error on 5 V input calibration
313	Error on 10 V input calibration
400	Control parameters error
500	Auto-zero error
502	RJ error
510	Error during calibration procedure

NOTES

- 1) When a configuration parameter error is detected, it is sufficient to repeat the configuration procedure of the specify parameter.
- 2) If error 400 is detected, push contemporarily the ▼ and ▲ pushbuttons for loading the default parameters then repeat control parameter setting.
- 3) For all the other errors, contact your supplier.

GENERAL INFORMATIONS

GENERAL SPECIFICATIONS

Case: Polycarbonate dark grey color (RAL 7043); self-extinguishing degree: V-0 according to UL 94.

Front protection - designed and tested for IP 65 (*) and NEMA 4X (*) for indoor locations (when panel gasket is installed).

(*) Test were performed in accordance with CEI 70-1 and NEMA 250-1991 STD.

Installation: panel mounting.

Rear terminal block: 15 screw terminals (screw M3, for cables from ϕ 0.25 to ϕ 2.5 mm² or from AWG 22 to AWG 14) with connections diagram and safety rear cover.

Dimensions: DIN 43700 48 x 48 mm, depth 122 mm.

Weight: 250 g.

Power supply:

- 100V to 240V AC 50/60Hz (-15% to + 10% of the nominal value).

- 24 V AC/DC (\pm 10 % of the nominal value).

Power consumption: 8 VA max.

Insulation resistance: > 100 M Ω according to IEC 1010-1.

Dielectric strength: 1500 V rms according to IEC 1010-1.

Display updating time: 500 ms.

Sampling time: 250 ms for linear inputs

500 ms for TC and RTD inputs.

Resolution: 30000 counts.

Accuracy: \pm 0,2% f.s.v.. \pm 1 digit @ 25 °C ambient temperature.

Common mode rejection: 120 dB @ 50/60 Hz.

Normal mode rejection: 60 dB @ 50/60 Hz.

Electromagnetic compatibility and safety requirements: This instrument is marked CE.

Therefore, it is conforming to council directives 89/336/EEC (reference harmonized standard

EN 50081-2 and EN 50082-2) and to council directives 73/23/EEC and 93/68/EEC (reference harmonized standard EN 61010-1).

Installation category: II

Temperature drift: (CJ excluded)

< 200 ppm/°C of span for mV and TC ranges 1, 3, 5, 6, 19, 20, 21, 22.

< 300 ppm/°C of span for mA/V

< 400 ppm/°C of span for RTD range 10, 26 and TC range 0, 2, 4, 27, 28.

< 500 ppm/°C of span for RTD range 9 and TC ranges 7,8, 23, 24.

< 800 ppm/°C of span for RTD range 25.

Operative temperature: from 0 to 50 °C (+32 to 122 °F).

Storage temperature: -20 to +70 °C (-4 to 158 °F)

Humidity: from 20 % to 85% RH, non condensing.

Protections:

- 1) WATCH DOG circuit for automatic restart.
- 2) DIP SWITCH for protection against tampering of configuration and calibration parameters.

INPUTS

A) THERMOCOUPLE

Type: L -J -K -N -R -S -T. °C/°F selectable.

External resistance: 100 Ω max, maximum error 0,1% of span.

Burn out: It is shown as an overrange condition (standard). It is possible to obtain an underrange indication by cut and short.

Cold junction: automatic compensation from 0 to 50 °C.

Cold junction accuracy : 0.1 °C/°C

Input impedance: > 1 M Ω

Calibration : according to IEC 584-1 and DIN 43710 - 1977.

STANDARD RANGES TABLE

T/C type	Ranges			
L	0	0 /+ 400.0°C		---
L	1	0/+ 900 °C	19	0 / + 1650 °F
J	2	-100.0/+ 400.0°C		---
J	3	-100 /+ 1000 °C	20	-150 / + 1830 °F
K	4	-100.0/+ 400.0°C		---
K	5	-100 /+ 1370 °C	21	-150 / + 2500 °F
N	6	-100 /+ 1400 °C	22	-150 / + 2550 °F
R	7	0 /+ 1760 °C	23	0 / + 3200 °F
S	8	0 /+ 1760 °C	24	0 / + 3200 °F
T	27	-199.9/+ 400.0°C	28	-330 / + 750 °F

B) RTD (Resistance Temperature Detector)

Input: for RTD Pt 100 Ω, 3-wire connection.

Input circuit: current injection.

°C/F selection: via front pushbuttons or serial link.

Line resistance: automatic compensation up to 20 Ω/wire with no measurable error.

Calibration: according to DIN 43760

Burnout: up scale. **NOTE:** a special test is provided to signal OVERRANGE when input resistance is less than 15 Ω.

STANDARD RANGES TABLE

Input type	Ranges	
RTD Pt 100 Ω DIN 43760	9	- 199,9 / + 400,0 °C
	10	- 200 / + 800 °C
	25	-199,9 / +400,0 °F
	26	-330 / + 1470 °F

C) LINEAR INPUTS

Read-out: keyboard programmable between -1999 and +4000.

Decimal point: programmable in any position

Burn out: the instrument shows the burn out condition as an underrange condition for 4-20 mA, 1-5 V and 2-10 V input types.

It shows the burn out condition as an underrange or an overrange condition (selectable by soldering jumper) for 0-60 mV and 12-60 mV input types. No indication are available for 0-20 mA, 0-5 V and 0-10 V input types.

Input type		impedance	Accuracy
11	0 - 60 mV	> 1 MΩ	0.2% + 1 digit @ 25°C
12	12 - 60 mV		
13	0 - 20 mA	< 5 Ω	
14	4 - 20 mA		
15	0 - 5 V	> 200 kΩ	
16	1 - 5 V		
17	0 - 10 V	> 400 kΩ	
18	2 - 10 V		

D) LOGIC INPUT

The instrument is equipped with one input from contact (voltage free) for setpoint selection.

Contact open = Main setpoint.

Contact closed = Auxiliary setpoint.

NOTES:

- 1) Use an external dry contact capable of switching 0.5 mA, 5 V DC.
- 2) The instrument needs 100 ms to recognize a contact status variation.
- 3) The logic input is **NOT** isolated by the measuring input.
- 4) This optional function is in alternative to amperometer sensing transformer input.

E) CURRENT TRANSFORMER INPUT FOR OUT1 FAILURE DETECTION

The instruments equipped with this feature are capable, by means of a CT, to detect and signal a possible failure of the line driven by out 1 (see "OUT 1 failure detection").

Input range: 50 mA AC.

Scaling: programmable from 10 A to 100 A (with 1 A step).

Resolution:

- for full scale up to 20 A: 0.1 A.

- for full scale from 21 A to 100 A: 1 A

Minimum duration of the period (ON or OFF)

to perform the measurement: 400 ms.

NOTE : this function excludes the logic input (external set point selection).

SET POINTS

This instrument allows to use 2 set points: SP and SP2.

The set point selection is possible only by logic input.

Set point transfer:

The transfer between one set point to another (or between two different set point values) may be realized by a step transfer or by a ramp with two different programmable rate of change (ramp up and ramp down).

Slope value: 1 - 100 eng. unit/min or step.

Set points limiter: RLO and RHI parameters, programmable.

CONTROL ACTIONS

Control action: PID + SMART

Type: One (heating or cooling) or two (heating and cooling) control outputs.

Proportional Band (Pb):

Range: - from 1.0 to 100.0 % of the input span for process with one control output.
- from 1.5 to 100.0 % of the input span for process with two control output.

When Pb=0, the control action becomes ON/OFF.

Hysteresis (for ON/OFF control action):

from 0.1% to 10.0% of the input span.

Integral time (Ti): from 1s to 20 min. or excluded.

Derivative time (Td): from 0 s to 10 min.

If zero value is selected, the derivative action is excluded.

Integral pre-load:

- from 0.0 to 100.0 % for one control output
- from -100.0 (cooling) to +100.0 % (heating) for two control output.

SMART: keyboard enabling/disabling

Auto/Manual: selectable by front pushbutton.

Auto/Manual transfer: bumpless method type

Indicator "MAN" : OFF in auto mode and lit in manual mode.

OUTPUTS

Control output updating time :

- 250 ms when a linear input is selected

- 500 ms when a TC or RTD input is selected.

Action: direct/reverse programmable by front keyboard.

Output level indication:

The instrument displays separately the output 1 level (heating) and the output 2 level (cooling).

Output status indication: Two indicators (OUT 1 and OUT 2) are lits when the respective output is in ON condition.

Output level limiter:

- For one control medium :
from 0 to 100 % .
- For two control mediums :
from -100 to +100 % .

This function may be operative at instrument start up for a programmable time (To avoid thermal shock and/or preheating the plant) otherwise it can be enabled by an external contact.

Cycle times:

- For out 1 it is programmable from 1 to 200 s.
- For out 2 it is programmable from 1 to 200 s.

Relative cooling gain: programmable from 0.20 to 1.00.

Overlap/dead band: programmable from - 20 % to + 50 % of the proportional band

OUTPUT 1

Type: relay SPDT contact (NO or NC selectable by jumper).

Contact rated: 3 A at 250 V AC on resistive load.

Output cycle time:programmable from 1 s to 200 s.

Function: programmable as heating or cooling output

OUTPUT 2

Type: relay SPST contact .

Contact rated: 2 A at 250 V AC on resistive load.

Function: programmable as:

- control output (cooling)
- Alarm 1 output

Output cycle time (when used as control output): programmable from 1 s to 200 s.

OUTPUT 3

Type: relay with SPST contact

Contact rated: 2 A at 250 V AC on resistive load.

Function: Alarm 2 output.

ALARMS

Actions: Direct or reverse acting.

Alarm functions: each alarm can be configured as process alarm, band alarm or deviation alarm.

Alarm reset: automatic or manual reset programmable on each alarm.

Stand by (mask) alarm: each alarm can be configured with or without stand by (mask) function.

This function allows to delete false indication at instrument start up and/or after a set point change.

Process alarm:

Operative mode : High or low programmable.

Threshold : programmable in engineering unit within the input span.

Hysteresis: programmable from 0.1 % to 10.0 % of the input span (P4 - P3).

Band alarm

Operative mode: Inside or outside programmable.

Threshold : programmable from 0 to 500 units.

Hysteresis : programmable from 0.1 % to 10.0 % of the input span.

Deviation alarm:

Operative mode : High or low programmable.

Threshold : programmable from - 500 to +500 units.

Hysteresis : programmable from 0.1 % to 10.0 % of the input span.

SERIAL COMMUNICATION INTERFACE

Type: RS-485 insulated.

Protocol type: MODBUS, JBUS, ERO polling/
selecting.

Baud rate: programmable from 600 to 19200
BAUD.

Byte format: 7 or 8 bit programmable.

Parity: even, odd or none programmable.

Stop bit : one.

Address :

- from 1 to 95 for ERO protocol
- from 1 to 255 for all the other protocols

Output voltage levels: according to EIA standard.

MAINTENANCE

- 1) REMOVE POWER FROM THE POWER SUPPLY TERMINALS AND FROM RELAY OUTPUT TERMINALS
- 2) Remove the instrument from case.
- 3) Using a vacuum cleaner or a compressed air jet (max. 3 kg/cm²) remove all deposit of dust and dirt which may be present on the louvers and on the internal circuits trying to be careful for not damage the electronic components.
- 4) To clean external plastic or rubber parts use only a cloth moistened with:
 - Ethyl Alcohol (pure or denatured) [C₂H₅OH] or
 - Isopropil Alcohol (pure or denatured) [(CH₃)₂CHOH] or
 - Water (H₂O)
- 5) Verify that there are no loose terminals.
- 6) Before re-inserting the instrument in its case, be sure that it is perfectly dry.
- 7) re-insert the instrument and turn it ON.

DEFAULT PARAMETERS

DEFAULT OPERATIVE PARAMETERS

The control parameters can be loaded with predetermined default values. These data are the typical values loaded in the instrument prior to shipment from factory. To load the default values proceed as follows:

- a) The internal switch (V101, see fig. 14) should be closed.
- b) The SMART function should be disabled.
- c) The instrument should be in Stand-by mode.
- d) Held down ▼ pushbutton and press ▲ pushbutton; the display will show:



A rectangular display showing the text "OFF" in large letters on the top line and "dFLt" in smaller letters on the bottom line.

- e) Press ▲ or ▼ pushbutton; the display will show:



A rectangular display showing the text "On" in large letters on the top line and "dFLt" in smaller letters on the bottom line.

- g) Press FUNC pushbutton; the display will show:



A rectangular display showing the text "LOAD" in large, bold letters.

It means that the loading procedure has been initiated.

After about 3 seconds the loading procedure is finished and the instrument reverts to NORMAL DISPLAY mode.

The following is a list of the default operative parameters loaded during the above procedure:

PARAMETER	DEFAULT VALUE
SP	= Minimum range-value
SnRT	= Disable
n.Rst	= OFF
SP2	= Minimum range value
nnn	= OFF
AL1, AL2	= Minimum range-value for process alarms 0 for deviation or band alarms
HSA1, HSA2	= 0.1 %
Pb	= 4.0 %
hyS	= 0.5 %
ti	= 4.00 (4 minutes)
td	= 1.00 (1 minute)
IP	= 30 %
Cy1	= 15 seconds for relay output 4 seconds for SSR output
Cy2	= 10 seconds for P8 = Alr 4 seconds for P8 = OIL 2 seconds for P8 = H2O
rC	= 1.00 for P8 = Alr 0.80 for P8 = OIL 0.40 for P8 = H2O
OLAP	= 0
rL	= Initial scale value
rH	= Full scale value
Grd 1	= Infinite (step transfer)
Grd 2	= Infinite (step transfer)
OLH	= 100 %
tOL	= Infinite
Hbd	= 50 % of the full scale value.
SCA	= 100 % of the full scale value.
rnP	= 25 % of the output per second.

DEFAULT CONFIGURATION PARAMETERS

The configuration parameters can be loaded with predetermined default values. These data are the typical values loaded in the instrument prior to shipment from factory. To load the default values proceed as follows:

- The internal switch should be open.
- The upper display will show:

CO nF

- Push the ▼ pushbutton; the display will show the firmware version.

CO nF
A. 0 0

- Maintaining the pressure on the ▼ pushbutton, push the ▲ pushbutton also. The instrument will show:

OFF
d F L t

- Press ▲ pushbutton to select between table 1 (European) or table 2 (American) default set parameters; the display will show:

t b 1
d F L t

- Press FUNC pushbutton; the display will show:

LOAD

It means that the loading procedure has been initiated.

After about 3 seconds the loading procedure is terminated and the instrument reverts to visualization as in point b.

PARA.	TABLE 1	TABLE 2
SEr 1	ErO	ErO
SEr 2	1	1
SEr 3	19.20	19.20
SEr 4	7E	7E
P1	3	20
P2	----	----
P3	0	0
P4	400	1000
P5	rEL	rEL
P6	rEV	rEV
P7	1	1
P8	Alr	Alr
P9	H.A.	H.A.
P10	OFF	OFF
P11	10	10
P12	0	0
P13	H.A	H.A.
P14	OPrt.	OPrt
P15	0	0
P16	0.1	0.1

P17	0	0
P18	0	0
P19	rEV	rEV
P20	OFF	OFF
P21	rEV	rEV
P22	OFF	OFF
P23	0	0
P24	Not available	Not available
P25	On	On
P26	On	On
P27	2	2
P28	OFF	OFF
P29	30	30
P30	1.5	1.5
P31	1.0	1.0
P32	00.50	00.50
P33	0	0
P34	Not available	Not available
P35	tn 10	tn 30
P36	nO.FL	nO.FL
P37	0	0
P38	0	0
P39	10	10
P40	Pld	Pld
P41	Fn.Sp	Fn.Sp
P42	0	0

PROHEAT

Excellence in distribution

<http://www.proheatinc.com>

117 East Adams Street

P.O. Box 48

LaGrange, KY 40031

Phone (502) 222-1402 Fax (502) 222-0714