

SPRUE TYPE (Small)

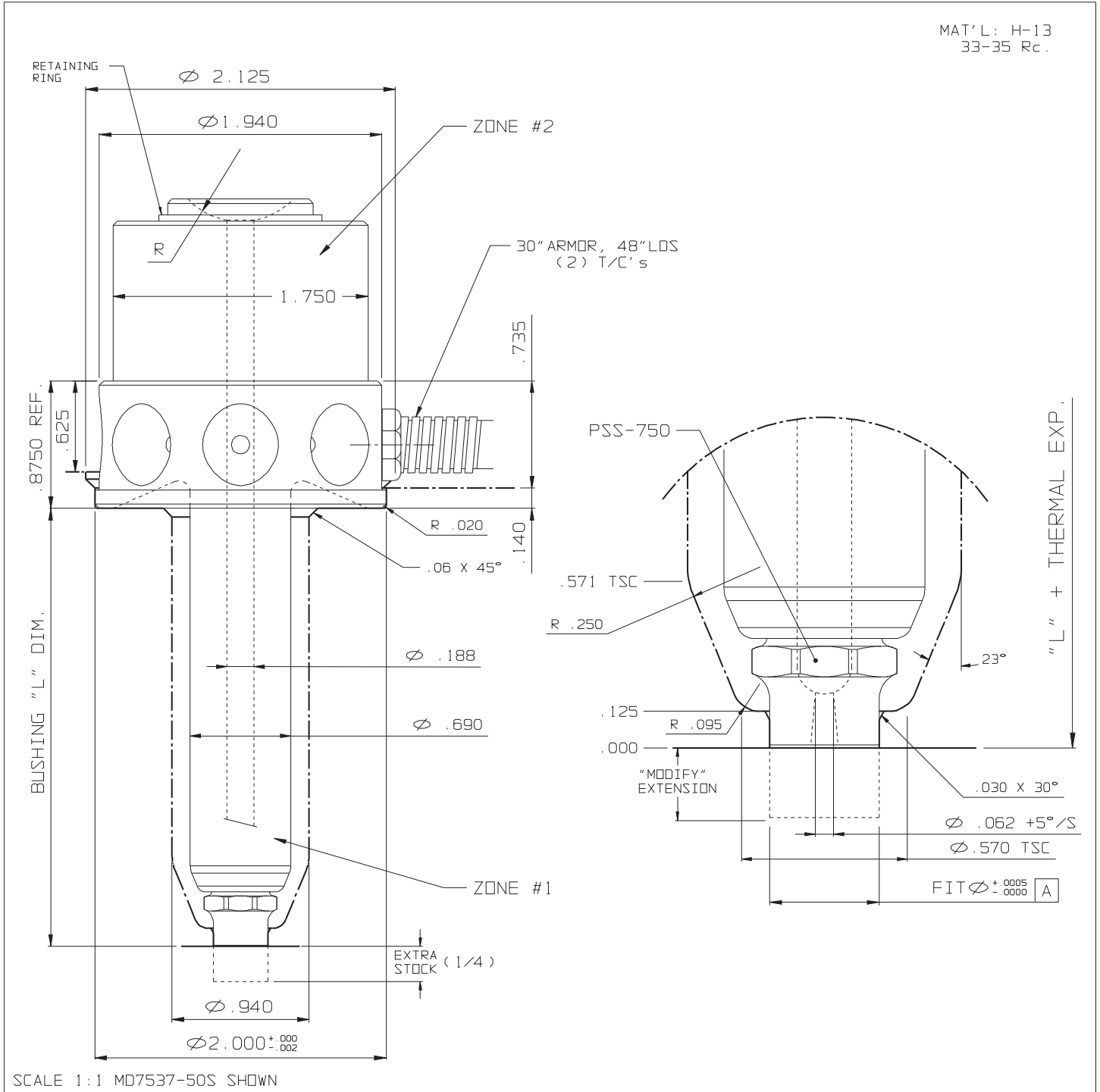

NOZZLE #		(220 V)		THERMAL EXPANSION ΔL @ (°F)				OPTIONS			
L	1/2" SPH. RAD.	3/4" SPH. RAD.	WATTS	T/C	370°F	460°F	550°F	640°F	END CAPS		
1.500	MD7523-50S	MD7523-75S	640	J2-06	0.003	0.005	0.006	0.007	STANDARD	EXTRA STOCK	FIT \varnothing
2.000	MD7527-50S	MD7527-75S	700	J2-10	0.004	0.006	0.007	0.009	PSS-750 MDS-750	PSS-750ES MDS-750ES	.375 .750
2.500	MD7533-50S	MD7533-75S	720	J2-10	0.005	0.007	0.009	0.011			
3.000	MD7537-50S	MD7537-75S	740	J2-10	0.006	0.009	0.011	0.013	GATE \varnothing		
3.500	MD7543-50S	MD7543-75S	770	J2-10	0.007	0.010	0.012	0.015	.062-.156	NONE	N/A
4.000	MD7547-50S	MD7547-75S	800	J2-10	0.008	0.011	0.014	0.016			