

SPRUE TYPE (Small)

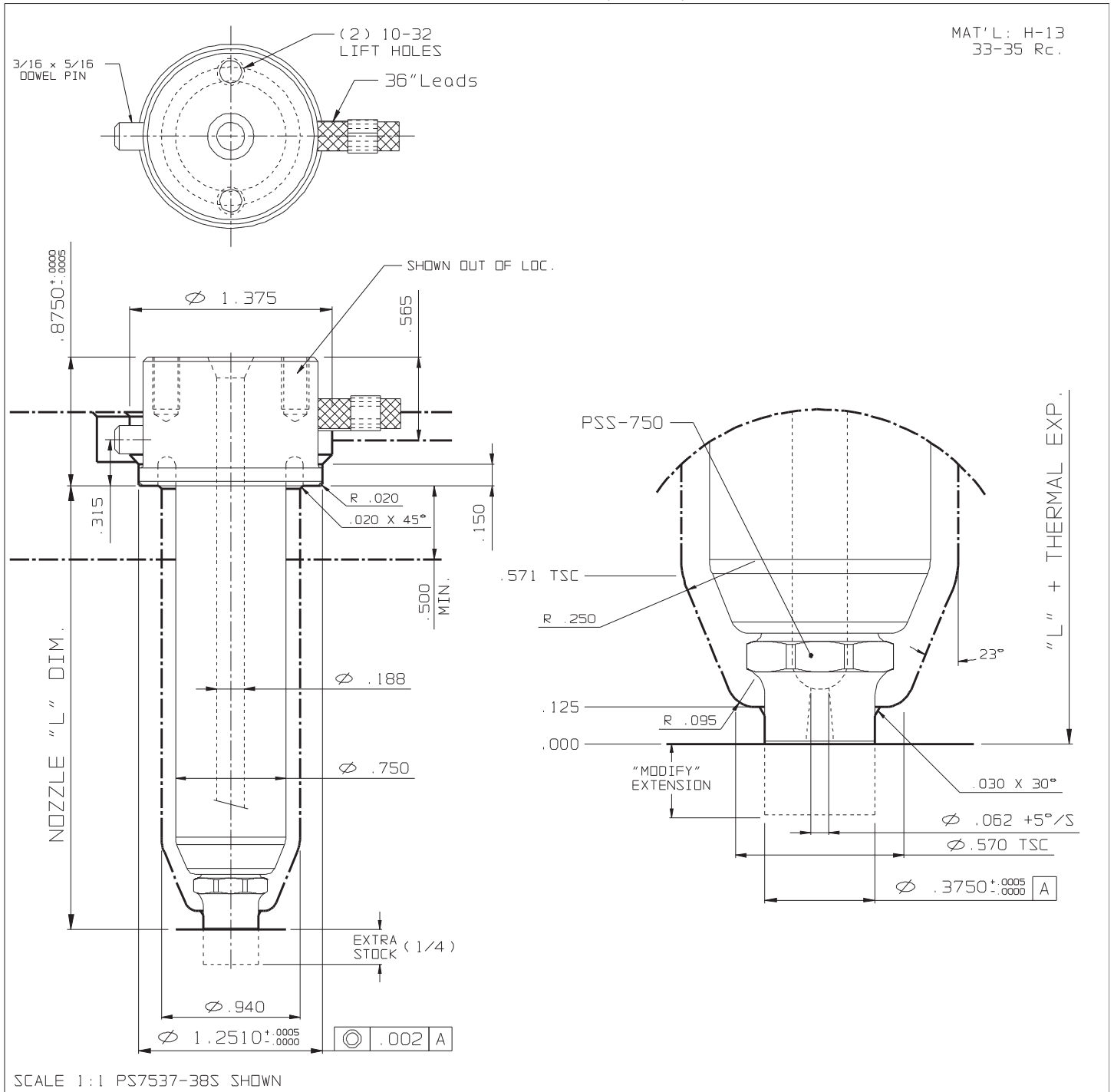

NOZZLE # (220V)					THERMAL EXPANSION ΔL @ (°F)				OPTIONS	
L	FLAT TYPE	O-RING TYPE	WATTS	T/C	370°F	460°F	550°F	640°F	END CAP	
1.000	PS7517-38S	PS7517-68S	220	J2-06	0.002	0.003	0.004	0.005	STANDARD	EXTRA STOCK
1.500	PS7523-38S	PS7523-68S	250	J2-06	0.003	0.005	0.006	0.007	PSS-750	PSS-750ES
2.000	PS7527-38S	PS7527-68S	310	J2-06	0.004	0.006	0.007	0.009		
2.500	PS7533-38S	PS7533-68S	330	J2-06	0.005	0.007	0.009	0.011	.062-.125	NONE
3.000	PS7537-38S	PS7537-68S	350	J2-10	0.006	0.009	0.011	0.013		
3.500	PS7543-38S	PS7543-68S	380	J2-10	0.007	0.010	0.012	0.015		
4.000	PS7547-38S	PS7547-68S	400	J2-10	0.008	0.011	0.014	0.016	GATE Ø	
4.500	PS7553-38S	PS7553-68S	500	J2-10	0.009	0.013	0.016	0.018		