

SPRUE TYPE (Large)

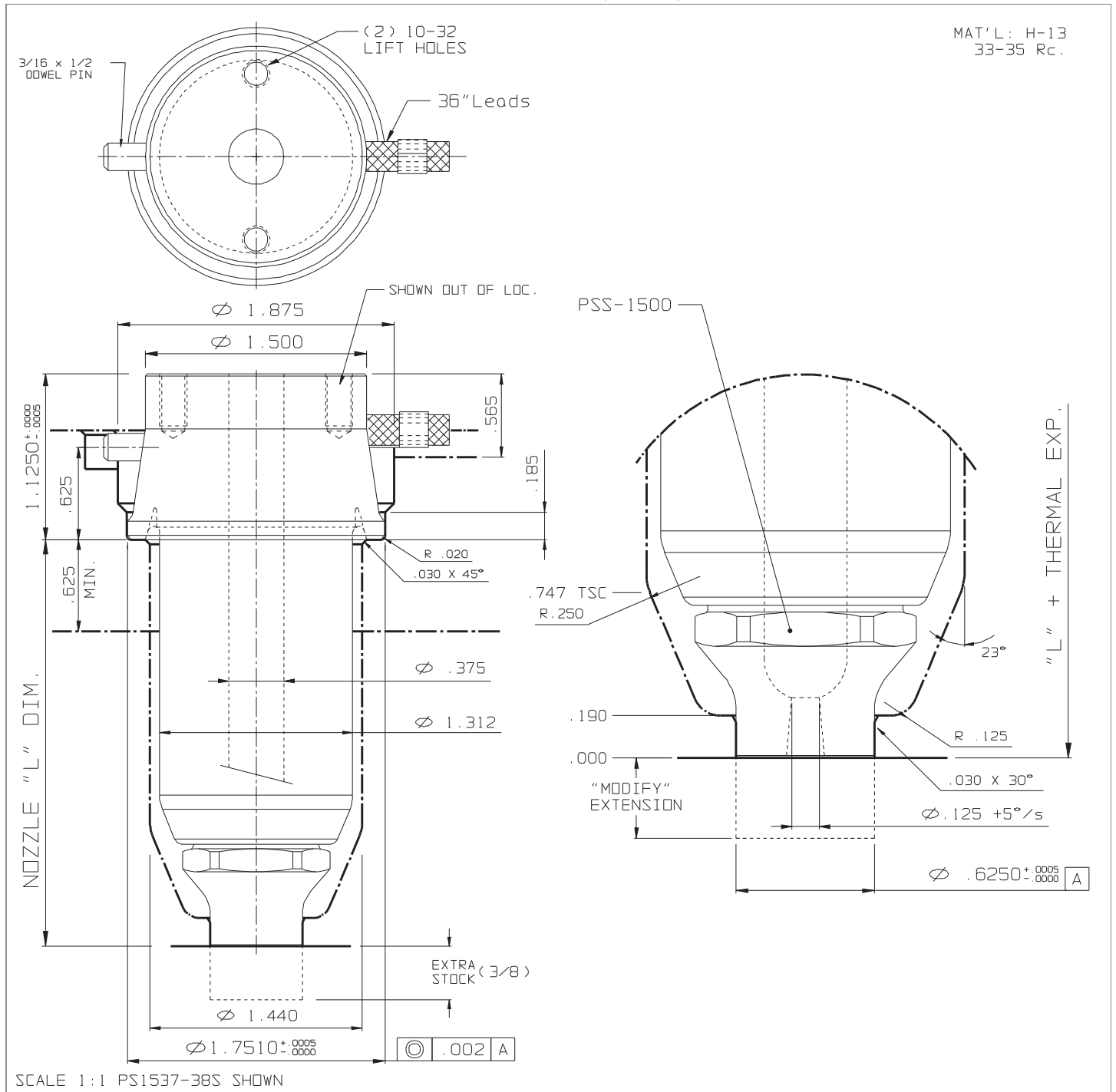

NOZZLE # (220V)					THERMAL EXPANSION ΔL @ (°F)				OPTIONS	
L	FLAT TYPE	O-RING TYPE	WATTS	T/C	370°F	460°F	550°F	640°F	END CAP	
1.750	PS1527-38S	PS1527-68S	410	J2-06	0.004	0.005	0.007	0.008	STANDARD	EXTRA STOCK
2.250	PS1533-38S	PS1533-68S	450	J2-06	0.005	0.007	0.008	0.010	PSS-1500	PSS-1500ES
2.750	PS1537-38S	PS1537-68S	480	J2-06	0.006	0.008	0.010	0.012		
3.250	PS1543-38S	PS1543-68S	530	J2-10	0.007	0.009	0.011	0.014	GATE Ø	
3.750	PS1547-38S	PS1547-68S	560	J2-10	0.008	0.011	0.013	0.016		
4.250	PS1553-38S	PS1553-68S	600	J2-10	0.009	0.012	0.015	0.017	STANDARD	EXTRA STOCK
4.750	PS1557-38S	PS1557-68S	630	J2-10	0.010	0.013	0.016	0.019	.125-.187	NONE
5.250	PS1563-38S	PS1563-68S	650	J2-10	0.011	0.015	0.018	0.021		