

TOPLESS (Extra Large)

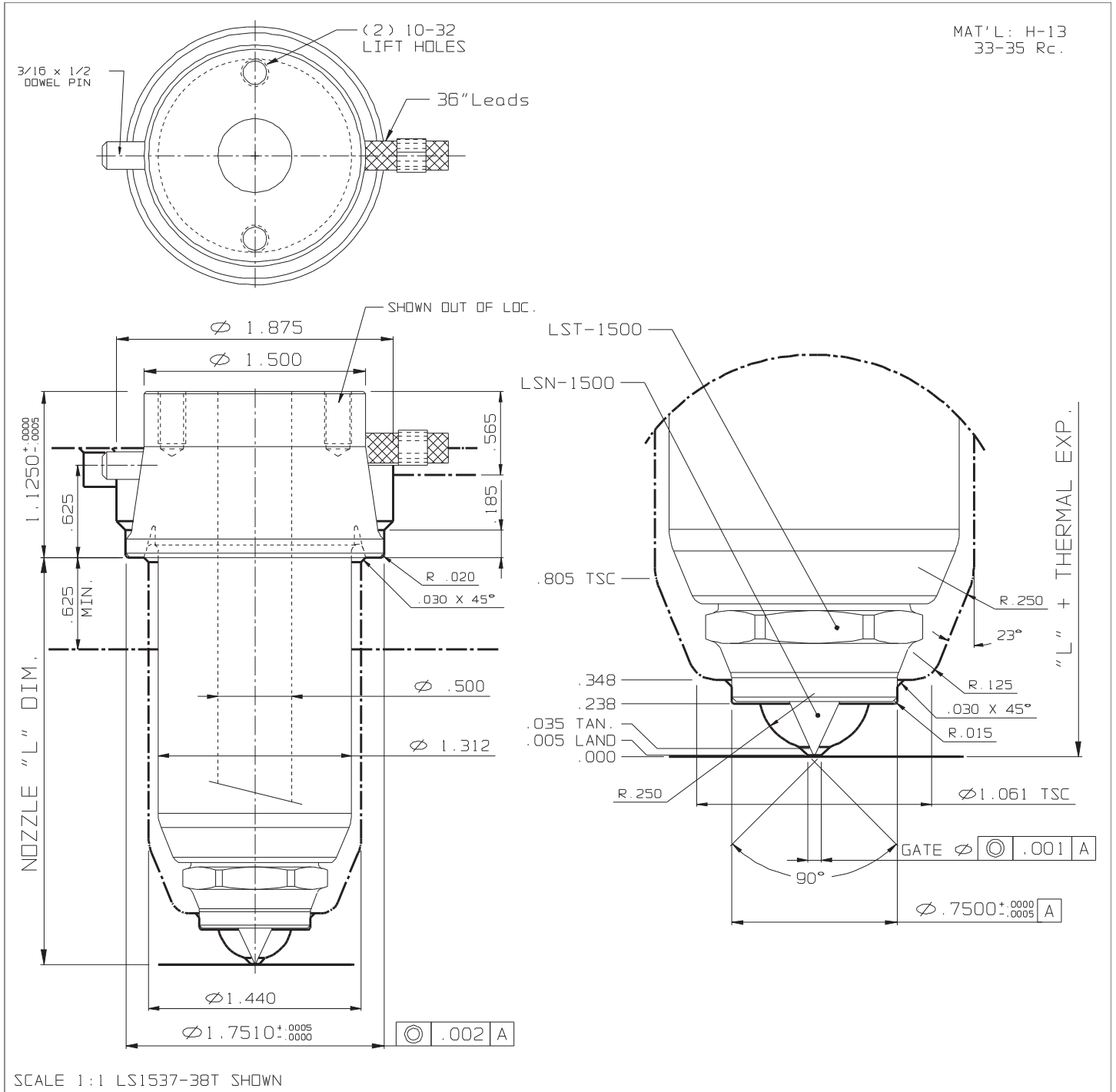

NOZZLE # (220V)					THERMAL EXPANSION ΔL @ (°F)				OPTIONS	
L	FLAT TYPE	O-RING TYPE	WATTS	T/C	370°F	460°F	550°F	640°F	END CAP	GATE Ø
1.750	LS1527-38T	LS1527-68T	410	J2-06	0.004	0.005	0.007	0.008	LST-1500	.060 - .094
2.250	LS1533-38T	LS1533-68T	450	J2-06	0.005	0.007	0.008	0.010		
2.750	LS1537-38T	LS1537-68T	480	J2-06	0.006	0.008	0.010	0.012		
3.250	LS1543-38T	LS1543-68T	530	J2-10	0.007	0.009	0.011	0.014	GATING NEEDLES	
3.750	LS1547-38T	LS1547-68T	560	J2-10	0.008	0.011	0.013	0.016		
4.250	LS1553-38T	LS1553-68T	600	J2-10	0.009	0.012	0.015	0.017	LSN-1500	LSN-1510
4.750	LS1557-38T	LS1557-68T	630	J2-10	0.010	0.013	0.016	0.019		
5.250	LS1563-38T	LS1563-68T	650	J2-10	0.011	0.015	0.018	0.021		