

Engineering Guide

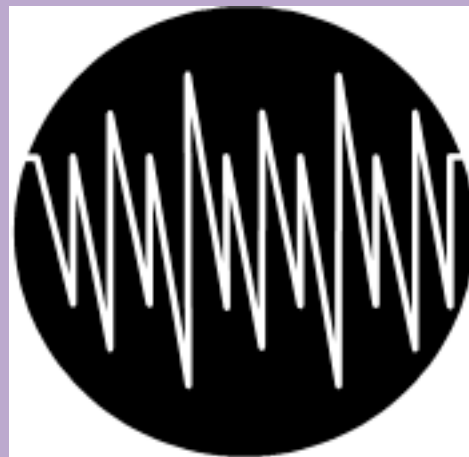
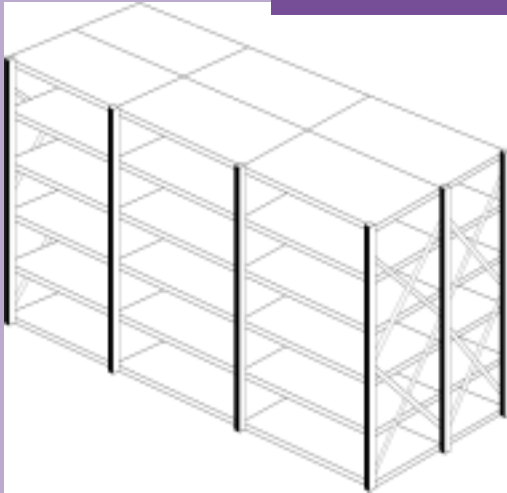
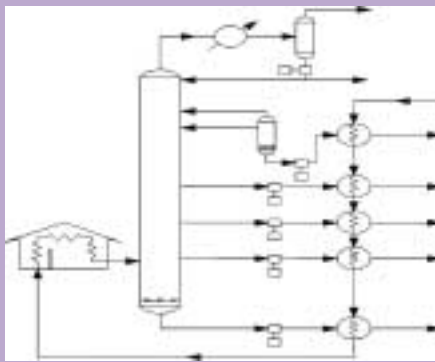
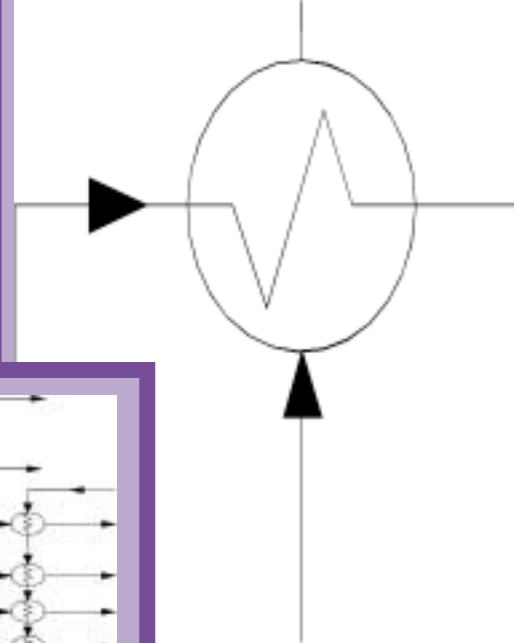
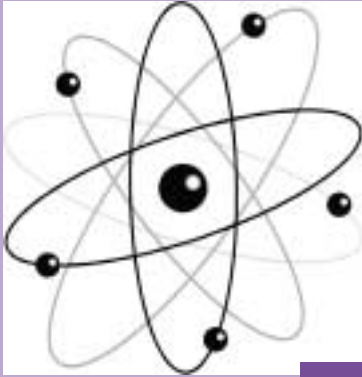

Proheat

sales@proheat.net
techhelp@proheat.net

117 East Adam St.
P.O. Box 48
La Grange, KY 40031

Free: 800.626.2142
Tel: 502.222.1402
Fax: 502.222.0714

Table of Contents

<u>DESCRIPTION</u>	<u>PAGE</u>
Introduction.....	3
Power Requirements Formulas.....	4
Energy Calculations - Short Method.....	5
Energy Calculations - Itemized Method.....	5-6
Heat Loss Curves.....	7
Watt Density Curves.....	8
Power Requirement Curves.....	8
Ohms Law.....	9
Wattage Requirement Chart.....	10
Properties of Materials.....	11-13
Material Emissivities.....	13
Heater Life Estimation.....	13
Guidelines for Watt Density & Operation Temperature.....	14
Corrosion Resistance of Materials.....	15-16
Equivalents and Conversions.....	17-20
Wire Current Carrying Capacity & Temperature Rating.....	21
Trigonometric Solutions.....	22
Wiring Configurations.....	23
Suggested Wiring Practices for Electric Heaters.....	24
Thermocouple Wire Selection.....	24
Temperature and Power Controls.....	25-28
Glossary.....	29-31



Introduction

This Engineering section covers the basic principles of thermal energy applications as related to electrical resistance type heaters. The foregoing information will assist an individual in selecting approximate requirements for various heating systems. It includes general calculations, engineering data, conversion charts, and suggested wiring practices for solving heating problems. As an aid to understanding basic electrical terminology, a glossary is included.

The purpose of this section is for basic electrical sizing of non-complex systems. For critical applications, Rama engineers are available to assist you in selecting components to meet your electrical heating requirements.

When selecting electrical heating systems, ambient air temperature, environment toxicity and safety should be considered. Also, a basic understanding of conduction, convection and radiation modes of heat transfer is helpful.

As always, Rama design and application engineers are eager to aid you in satisfying your electrical requirements. We are experts in the electrical heating field and try to use off-the-shelf solutions to supply you a high quality, low cost product.

This section is designed only as a guide. Rama has produced this guide in order to assist the customer in choosing the correct heater for their application. However, the customer hereby releases Rama from all liability not specifically assumed by Rama hereunder. See Rama's Terms and Conditions for additional information on liability.

POWER REQUIREMENT FORMULAS

Several conditions must be considered when determining process heating requirements. Energy required to bring a system up to operating temperature in a desired time (start-up) and the energy required to maintain the operating temperature must be determined. The total power required (KW) to satisfy the system needs will be the greater of the two values plus a safety factor.

It is helpful to define the heating system problem including sketches and statement of requirements. Some considerations would include:

- Operating heat losses from exposed surfaces.
- Insulation requirements.
- Operating temperatures (beginning and final).
- Time to reach temperature.
- Environmental factors (i.e. ambient temperature).
- Flow rates of process materials and cycle time.
- Mechanical and thermal properties of process materials.
- Size of container including weight, thermal properties, and other medium that will absorb heat energy.
- Type of temperature control used.

SHORT & ITEMIZED METHODS

The Short Method can be used as a quick estimate to approximate energy needs. The Itemized Method includes the properties of conduction, convection and radiation in determining heating properties. The following equations and steps permit calculations to determine wattage requirements for specific applications.

STEP 1: Calculate the power required to heat your material and the associated equipment in contact with the material heated.

STEP 2: Calculate the power required to heat the added material introduced when equipment is operated.

STEP 3: Calculate the power required to melt or vaporize the material during heat-up and operation time.

STEP 4: Calculate the power lost from surfaces.

STEP 5: Determine the greater energy required between start-up power and operating power plus a safety factor.

EQUATIONS: SHORT METHOD

EQUATION 1: For step 1 and Step 2 use the following equation:

$$KW = \frac{\text{Weight of mat'l (lb)} \cdot \text{Specific Heat (BTU/lb} \cdot \text{ }^\circ\text{F)} \cdot \text{Temperature Difference (}^\circ\text{F)}}{3412 \text{ (BTU/KWH)} \cdot \text{Time allowed for heat-up time (hr)}}$$

EQUATION 2: For step 3 use the following equation:

$$KW = \frac{\text{Wgt. of mat'l (lb)} \cdot \text{Heat of fusion and/or vaporization (BTU/lb)}}{3412 \text{ (BTU/KWH)} \cdot \text{Time allowed for heat-up time (hr)}}$$

EQUATION 3: For step 4 use the following equation:

$$KW = \frac{\text{Thermal conductivity of mat'l and/or insulation} \cdot \text{Surface area (ft}^2\text{)} \cdot \text{Temperature Difference (}^\circ\text{F)}}{3412 \text{ BTU/KWH} \cdot \text{Thickness of material and/or insulation (in.)}}$$

EQUATION 4: For step 5 use the following equation:

Power required for start-up operations:
Total KW = (Step 1 + Step 3, if applicable + 2/3 Step 4) • 1.15

Power required for sustained operations:
Total KW = (Step 2 + Step 3, if applicable, + Step 4) • 1.15

From these steps, determine the greater power required of the two calculations to size your heater, a safety contingency of 15% is included.

EQUATIONS: ITEMIZED METHOD

EQUATION 1: Heat required to raise temperature of material (watt-hours).

$$Q1 \text{ or } Q2 = \frac{W \cdot C_p \cdot CT}{3.412}$$

Q = Heat required to raise temperature of material during heat-up or when added material is introduced.

W = Weight of material (lb)

C_p = Specific heat of material (btu/lb • °F)

CT = Temperature difference (°F)

EQUATION 2: Heat required to vaporize or melt material (watt hours).

$$Q_m = \frac{W \cdot H_f}{3.412} \quad Q_v = \frac{W \cdot H_v}{3.412}$$

Q3 = Q_m or Q_v for start-up

Q4 = Q_m or Q_v for working cycle

Q_m = Heat required to melt material

Q_v = Heat required to vaporize material

W = Weight of material (lb)

H_f = Latent heat of fusion (BTU/lb)

H_v = Latent heat of vaporization (BTU/lb)

EQUATION 3A: Heat loss - Conduction (watt-hours).

$$QL1 = \frac{k \cdot A \cdot CT \cdot t_e}{3.412 \cdot L}$$

EQUATION 3B: Heat loss - Convection (watt-hours).

$$QL2 = A \cdot F_L \cdot C_{SF} \cdot t_e$$

EQUATION 3C: Heat loss - Radiation (watt-hours).

$$QL3 = A \cdot F_L \cdot e \cdot t_e$$

EQUATION 3D: Heat loss - Combined convection and radiation (watt-hours).

$$QL4 = A \cdot F_L \cdot t_e$$

Q = Heat loss (conduction, convection or radiation)

k = Thermal Conductivity (btu • in/ft² • °F • hour)

A = Surface area associated with heat loss (ft²)

L = Thickness of material (in)

CT = Temperature difference (°F)

t_e = Time of heat loss (hours)

F_L = Surface loss factor (W/ft²) (Use as required for convection, radiation, and combined convection/radiation)

C = Surface orientation factor: 1.29 (top), 0.63 (bottom), 1.00 (vertical)

EQUATION 3E: Heat loss - Total.

$$QL = QL1 + QL2 + QL3$$

or

$$QL = QL1 + QL4$$

if combined convection and radiation losses are used.

EQUATION 4: Start-up Power (watts).

$$P_s = \left[\frac{Q1 + Q3}{t_s} + \frac{2}{3} \left(\frac{QL}{t_e} \right) \right] \cdot (1 + SF)$$

EQUATION 5: Maintaining Power (watts).

$$P_m = \left[\frac{Q2 + Q4}{t_c} + \left(\frac{QL}{t_e} \right) \right] \cdot (1 + SF)$$

Q1 = Heat required to raise material temperature during start-up (WH)

Q2 = Heat required to raise material temperature when added material is introduced (WH)

Q3 = Latent heat of fusion/evaporation during start-up (WH)

Q4 = Latent heat of fusion/evaporation when added material is introduced (WH)

QL = Total losses - Conduction, Convection, Radiation (WH)

t_s = Start-up time (hr)

t_c = Cycle time (hr)

t_e = Exposure time (hr)

SF = Safety Factory (normally 15%)

When performing calculations using the Itemized Method, often some of the heat loss factors may be negligible and need not be taken into consideration. Conduction in many cases is the primary contribution to heat loss.

After the power requirements have been determined, the appropriate heaters should be selected. The heater temperature will always be higher than the material process temperature. The maximum heater temperature allowed is dependent on the heat transfer path (i.e. hole fit for cartridge heater) and amount of insulation. The heater allowable watt density (w/in²) as a function of heater surface temperature should be verified by means of the charts and graphs shown in this section.



Energy Calculations

Short Method

EXAMPLE #1

It is desired to heat a platen to 350° F in 1 hour. The two halves of the platen weigh 490 lbs. total and measure 12" • 18" • 4". The platen is made of mild steel and covered with 1" of insulation.

- w Weight of material = 490 lbs
- w Temp. Difference = temp. increase (350 - 70° F)
- w Specific heat = 0.12 BTU/lb • °F for mild steel
- w Heat up time = 1 hour
- w Thermal Conductivity =
approx. 0.67 BTU • in/ft² • °F • hr for insulation
- w Surface Area = 880 in² (6.11 ft²)
- w Insulation thickness = 1"

STEP 1: Power to heat material (equation #1)

$$KW = \frac{490 \text{ lb.} \cdot 0.12 \cdot (350-70)}{3412 \cdot 1 \text{ hr.}} = 4.825 \text{ KW}$$

STEP 2 and **STEP 3** are not required due the fact that no material is being added or is being melted or vaporized.

STEP 4: Power loss from surfaces (alternate - use Figure 1 Heat Loss Graph) Equation #3.

$$KW = \frac{0.67 \cdot 6.11 \text{ ft}^2 \cdot (350-70)}{3412 \cdot 1"} = 0.336 \text{ KW}$$

STEP 5: Determine energy required plus safety factor.

$$\text{Total KW} = (4.825 \text{ KW} + 2/3 \cdot 0.336 \text{ KW}) \cdot 1.15 = 5.806 \text{ KW}$$

The Start-up requirement is the governing power for this system. There is adequate space to install cartridge heaters in the platen. Six 1/2" diameter x 12" long cartridge heaters will be installed in each platen half. Each heater will be rated at 220V, 500 watts totaling 6000 watts. The watt density of each heater is approx. 27 watts/in² which is below the maximum allowable temperature (see Fig. 11 graph). Hole fit should be kept to a minimum, suggesting maximum total clearance of 0.005".

EXAMPLE #2

How much power is required to melt 100 lbs of aluminum in 1 hour?

Use Short Method Equation #2.

- Weight of Material = 100 lbs
- Heat of Fusion = 169 BTU/hr
- Time = 1 Hr

$$KW = \frac{100 \text{ lbs} \cdot 169 \text{ BTU/hr}}{3412 \text{ BTU/KWH} \cdot 1 \text{ hr}} = 4.953 \text{ KW}$$

EXAMPLE #3

Find power required to heat 10 gallons per minute of water from 68°F to 150°F.

Use Short Method equation #1.

- ♦ Flow Rate = 10 GPM
- ♦ Temperature Difference = 150 - 68°F
- ♦ Density of Water = 62.4 lbs/ft³ (8.34 lbs/gal)
- ♦ Specific Heat = 1.0 BTU/lb • °F

$$\text{Weight} = 10 \text{ GPM} \cdot 8.34 \text{ lbs/gal} \cdot 60 \text{ min/hr} = 5004 \text{ lbs/hr}$$

$$KW = \frac{5004 \cdot 1.0 \cdot (150-68)}{3412 \cdot 1.0} = 120.3 \text{ KW}$$

Energy Calculations

Itemized Method

EXAMPLE #4

Estimate radiation heat loss of polished 304 stainless steel at 700°F. Use Itemized Method Equation #3c.

- ♦ A = 1 in² (surface area)
- ♦ F = 6.96 W/in² Black Body Radiation Factor (see Fig. 2 graph for Oxidize Steel curve - use for Black Body)
- ♦ e = 0.17 (emissivity correction factor) see table 9
- ♦ t_e = 1 hour exposure time

$$QL_3 = A \cdot F \cdot e \cdot t_e$$

$$Q = 1 \cdot 6.96 \cdot 0.17 \cdot 1 = 1.18 \text{ W/in}^2$$

EXAMPLE #5

The open tank in figure 1 - 1, is filled with water to within 3" of the top. It is desired to heat the tank and water to 150°F in 1 hour. The tank size is 50" long x 15" wide x 30" high and holds 88 gallons of water. The tank weighs 100 lbs and the sides are covered with 2" thick insulation.

- Initial Temperature = 60°F
- Final Temperature = 150°F
- Heat up Time = 1 hour
- Tank Weight = 100 lbs
- Water Volume = 88 gallons
- Insulation Thickness = 2"

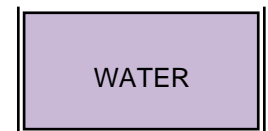

Figure 1-1

As in the Short Method, the 5 steps to calculate power requirements should be followed. Steps 2 and 3 will be omitted since no material is being added nor is there a material phase change.

STEP 1A: Heat Requirement Calculation: The power required to heat the stainless steel tank (Equation 1).

$$Q_T = \frac{W \cdot C_p \cdot \Delta T}{3.412} = \frac{100 \text{ lbs} \cdot .12 \text{ BTU/lb} \cdot \text{°F} \cdot 90\text{°F}}{3.412 \text{ (BTU/WH)}} = 316.53 \text{ (WH)}$$

Where:

- Q_T = Heat required to raise temperature of material, watt hours.
- W = Weight of material, lb = 100 lbs.
- C_p = Specific heat of material, (BTU/lb °F). See Table 7.
- ΔT = Temperature change = 150°F - 60°F = 90°F

STEP 1B: The Power required to heat water (Equation 1).

$$Q_W = \frac{732.5\text{lbs} \cdot 1.0 \text{ BTU/lb}^\circ\text{F} \cdot 90^\circ\text{F}}{3.412 \text{ (BTU/WH.)}} = 19,321.51 \text{ (WH)}$$

Where:

- W = Weight of Water = $4.1667 \cdot 1.25 \cdot 2.25 = 11.72\text{ft}^3 \cdot 62.5 = 732.5\text{lbs}$.
Density of Water = 62.5 (lb/ft³)
- C_p = Specific heat of Water = 1.0 (BTU/lb. °F) See table 5.
- XT = Temperature change = 150°F - 60°F = 90°F

STEP 1C: Total power to heat tank and water.

$$Q_1 = Q_T + Q_W$$

$$Q_1 = 317 \text{ (WH)} = 19,321 \text{ (WH)} = 19,638 \text{ (WH)}$$

STEP 2: Power required to heat the added material introduced when equipment is operated. NOT REQUIRED.

STEP 3: Power required to melt or vaporize the material during heat-up and operation. NOT REQUIRED.

STEP 4A: Heat Loss Equation. Heat loss from water surface: open tank top. (Equation 3d).

$$Q_{LWS} = A \cdot F_L \cdot t_e = 5.208\text{ft}^2 \cdot 216 \text{ (W/ft}^2) \cdot 1 \text{ (hr)} = 1125 \text{ (WH)}$$

Where:

- Q_{LWS} = Heat loss from a surface, (watt hours)
- A = Surface area associated with heat loss, (ft²)
 $.1667 \cdot 1.25 = 5.208 \text{ ft}^2$
- F_L = Heat loss factor, (watts/ft²)
 $1.5 \text{ (w/ft}^2) \cdot 1 \text{ ft}^2 = 144\text{in} = 216 \text{ (w/ft}^2)$ (See Fig. 3 graph)
- t_e = Time of heat loss (hours) = 1 hour

STEP 4B: Heat loss from tank (vertical surfaces): Metal Surfaces with 2" insulation (Equation 3d)

$$Q_{LTV} = A \text{ (ft}^2) \cdot F_L \cdot t_e$$

$$\text{Insulated } Q_{LTV} = 24.375 \text{ (ft}^2) \cdot 7.2 \text{ (W/ft}^2) \cdot 1 \text{ (hr)} = 175.5 \text{ (WH)}$$

Where:

- A = Vertical surfaces area of tank = $2 \cdot \{[4.1667 \cdot 2.25 \text{ (ft)}] + [1.25 \cdot 2.25 \text{ (ft)}]\} = 24.375 \text{ (ft}^2)$
- F_L = Heat loss factor for insulated metal surface from Fig. #1 Graph (Approx. .05w/ln²)
- t_e = Time of heat loss = 1hr

STEP 4C: Heat loss from tank - bottom surface (Equation 3d).

$$Q_{LTB} = 5.208 \text{ (ft}^2) \times 55 \text{ (W/ft}^2) \times 1 \text{ (hr)} = 286.44 \text{ (WH)}$$

Where:

- A = Area of bottom of tank = 4.1667x 1.25 (ft) = 5.208 (ft²)
- F_L = Heat loss factor from Fig. 2 graph = 100 (W/ft²)
- t_e = Time of heat loss = 1 hr

STEP 4D: Total Losses (Equation 3e)

$$QL = QLWS + QLTY + QLTB = 1125 + 176 + 286 = 1587 \text{ (WH)}$$

total losses.

STEP 5: Wattage required to Heat Tank system with 1.15 safety factor (Equation 4).

$$P_S = \left[\frac{Q_1 + Q_2 + \frac{2}{3} \left(\frac{Q_L}{t_e} \right) \right] \cdot (1 + SF)$$

$$P_S = \left[\frac{19,638\text{WH} + 0\text{WH}}{1\text{hr}} + \frac{2}{3} \left(\frac{1587\text{WH}}{1\text{hr}} \right) \right] \cdot (1 + .15)$$

$$P_S = 23,800 \text{ Watts} \quad t_s = \text{start-up time}$$

The maximum recommended heater watt density for water is 60 (W/in²) (see table 10). Therefore it is recommended, in this application, to use three screw-in immersion heaters with three heaters per assembly at 8,000 watts each or 24,000 watts total. Always round your wattage up to allow for manufacturing tolerances.

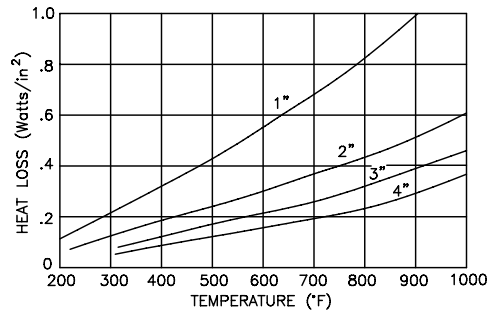

FIGURE 1: Heat loss through various thickness insulation (K = .67 @ 200°F and .81 @ 900°F)

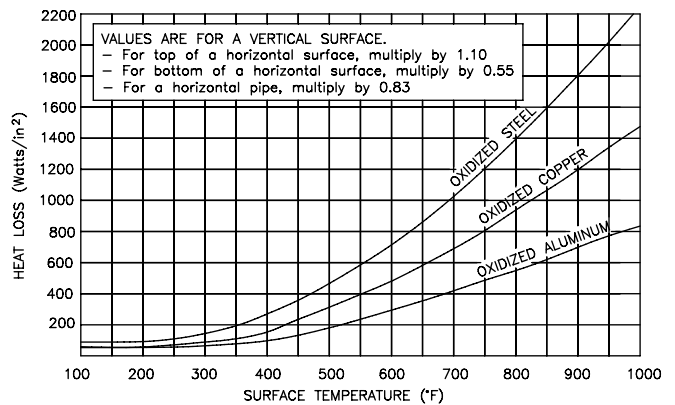

FIGURE 2: Combined convection and radiation heat loss from uninsulated metal surfaces.

Note: Use oxidized steel curve to approximate black body radiation.



Heat Loss Curves

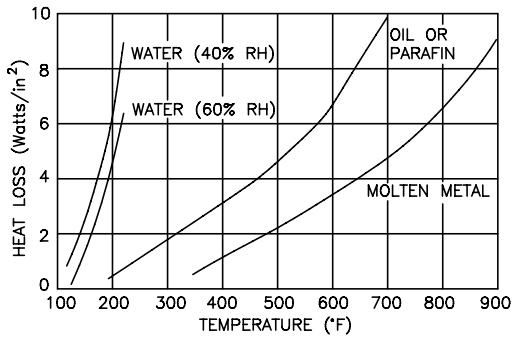

FIGURE 3: Heat loss from surface of fluids.

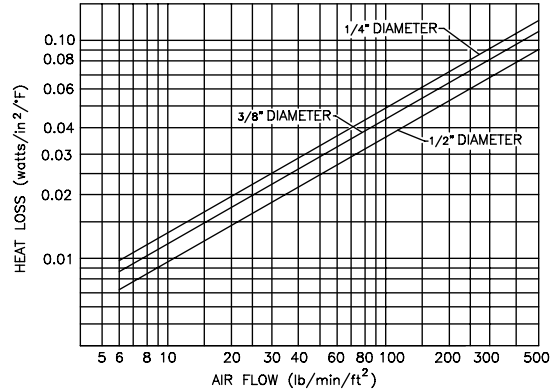

FIGURE 4: Heat transfer from tubular heaters to air by forced convection.

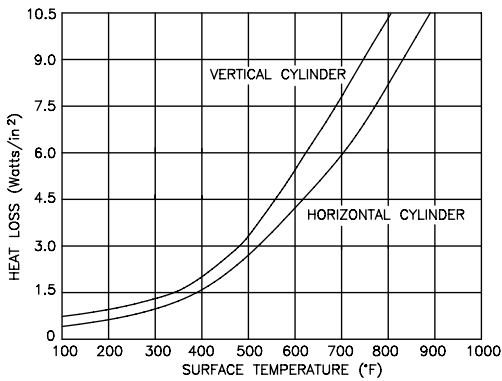

FIGURE 5: Heat loss from uninsulated steel cylinders.

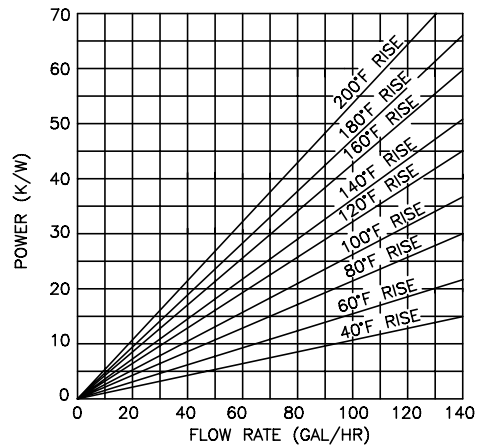

FIGURE 6: Heat required to raise water temperatures.

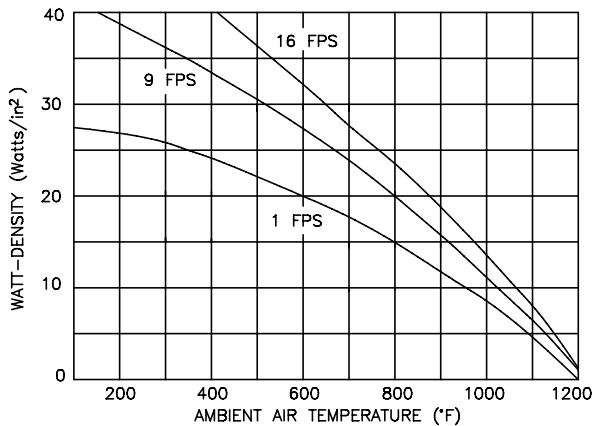

FIGURE 7: Allowable watt-density, metal sheath heaters in distributed air velocity at various temperatures.

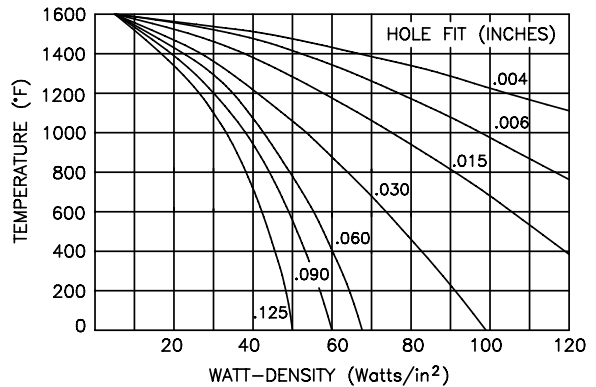

FIGURE 8: Temperature variation with change in watt-density and hole fit, metal sheath heaters in metal plates and molds.

Watt-Density & Power Requirement Curves

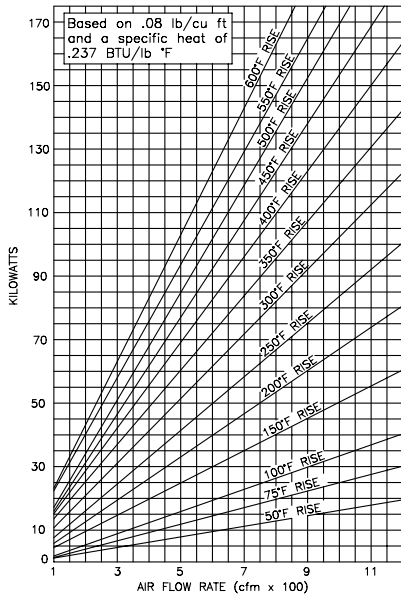

FIGURE 9: Heat-up requirements for air for varying rise of temperature.

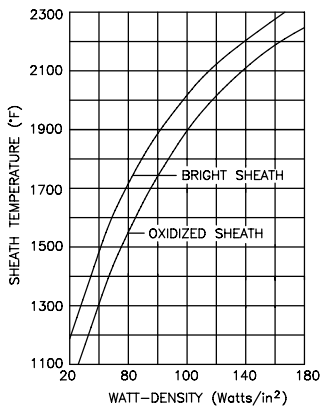

FIGURE 11: High watt-density vs. temperature for metal sheath heaters in still air (78°F).

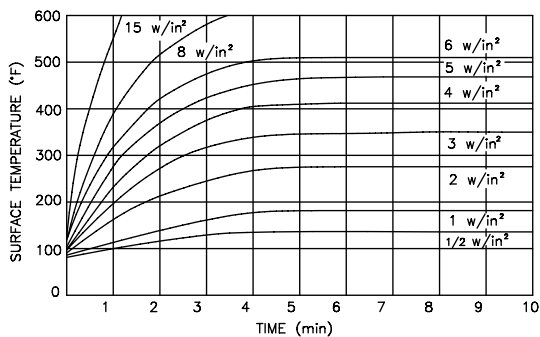

FIGURE 13: Heat-up time vs. surface temperature for flexible blanket heaters (with varying watt-densities) suspended in still air.

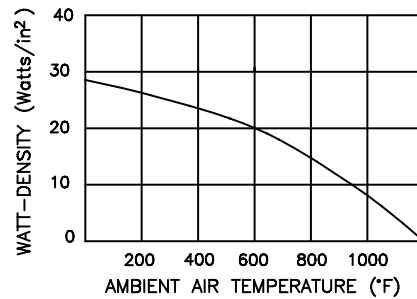

FIGURE 10: Recommended maximum watt-density vs. varying ambient air temperature for metal sheath heaters.

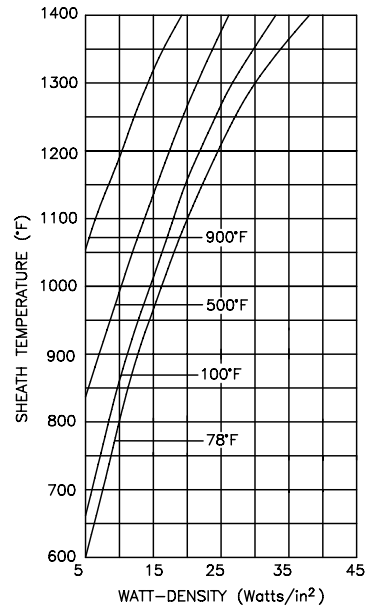

FIGURE 12: Metal sheath heater temperature at various watt-densities and air temperatures.

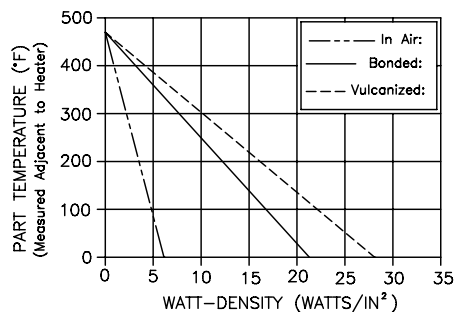

FIGURE 14: Maximum recommended watt-density for flexible rubber heaters vs. part (or ambient air) temperature for various mounting methods. For applications where watt-density may be higher consult factory.



RAMA CORPORATION Ohm's Law

VOLTS (E)

$$\text{Volts} = \sqrt{\text{Watts} \cdot \text{Ohms}}$$

$$\text{Volts} = \frac{\text{Watts}}{\text{Amperes}}$$

$$\text{Volts} = \text{Amperes} \cdot \text{Ohms}$$

AMPERES (I)

$$\text{Amperes} = \frac{\text{Volts}}{\text{Ohms}}$$

$$\text{Amperes} = \frac{\text{Watts}}{\text{Volts}}$$

$$\text{Amperes} = \sqrt{\frac{\text{Watts}}{\text{Ohms}}}$$

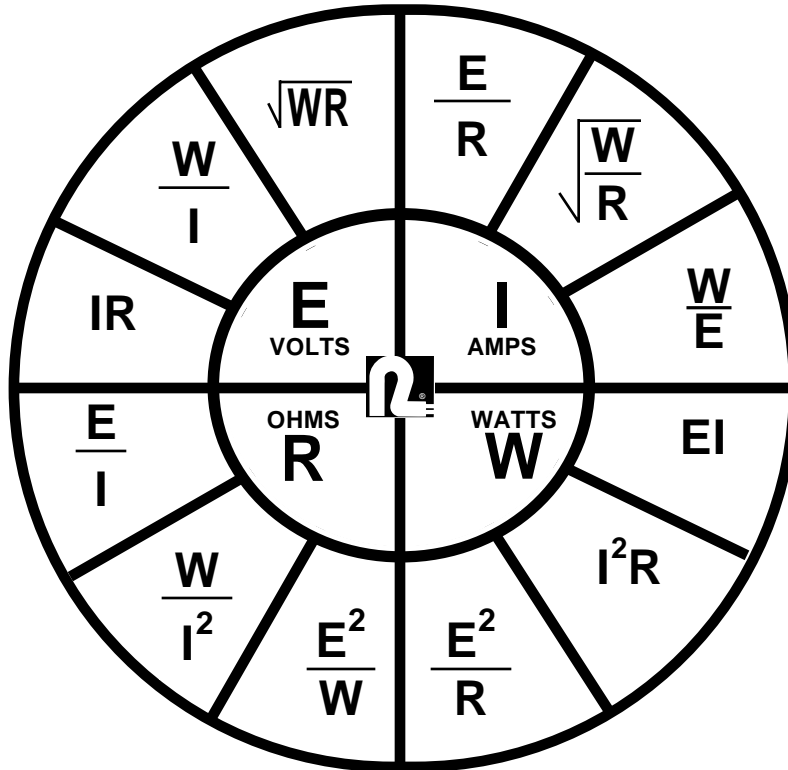

OHMS (R)

$$\text{Ohms} = \frac{\text{Volts}}{\text{Amperes}}$$

$$\text{Ohms} = \frac{\text{Volts}^2}{\text{Watts}}$$

$$\text{Ohms} = \frac{\text{Watts}}{\text{Amperes}^2}$$

WATTS (W)

$$\text{Watts} = \frac{\text{Volts}^2}{\text{Ohms}}$$

$$\text{Watts} = \text{Amperes}^2 \cdot \text{Ohms}$$

$$\text{Watts} = \text{Volts} \cdot \text{Amperes}$$

Wattage varies directly as ratio of voltages squared:

$$W_2 = W_1 \cdot \left(\frac{E_2}{E_1} \right)^2$$

$$3 \text{ Phase Amperes} = \frac{\text{Total Watts}}{\text{Volts} \cdot 1.732}$$

WATT DENSITY CALCULATIONS

BAND HEATERS:

$$\text{watts/in}^2 = \frac{\text{Wattage}}{\text{Dia.} \times 3.1416 \cdot \text{Width}}$$

CARTRIDGE & TUBULAR HEATERS:

$$\text{watts/in}^2 = \frac{\text{Wattage}}{\text{Dia.} \times 3.1416 \cdot \text{Heated Length}}$$

STRIP HEATERS:

$$\text{watts/in}^2 = \frac{\text{Wattage}}{\text{Heated Length} \cdot \text{Width}}$$

Wattage Requirement Charts

Table 1: To Heat Steel

WEIGHT IN LBS	TEMPERATURE RISE (°F)						
	50'	100'	200'	300'	400'	500'	600'
25	.06	.12	.25	.37	.50	.65	.75
50	.12	.25	.50	.75	1.00	1.25	1.50
100	.25	.50	1.00	1.50	2.00	2.50	3.00
150	.37	.75	1.50	2.25	3.00	3.75	4.50
200	.50	1.00	2.00	3.00	4.00	5.00	6.00
250	.65	1.25	2.50	3.75	5.00	6.25	7.50
300	.75	1.50	3.00	4.50	6.00	7.50	9.00
400	1.00	2.00	4.00	6.00	8.00	10.00	12.00
500	1.25	2.50	5.00	7.50	10.00	12.50	15.00
600	1.50	3.00	6.00	9.00	12.00	15.00	18.00
700	1.75	3.50	7.00	10.50	14.00	17.50	21.00
800	2.00	4.00	8.00	12.00	16.00	20.00	24.00
900	2.25	4.50	9.00	13.50	18.00	22.50	27.00
1000	2.50	5.00	10.50	15.00	20.00	25.00	30.00

KW TO HEAT IN 1 HOUR

Includes 20% safety factor to compensate for heat losses and/or low volume.

FOR STEEL

$$KW = \frac{\text{Kilograms} \cdot \text{Temp. Rise (°C)}}{5040 \cdot \text{Heat-up Time (hrs)}}$$

* Measured at normal temperature and pressure.

** Measured at greater system inlet temperature and pressure.

Table 3: To Heat Water

FT ³ /HR	GAL /HR	TEMPERATURE RISE (°F)						
		20'	40'	60'	80'	100'	120'	140'
.66	5	0.3	0.5	0.8	1.1	1.3	1.6	1.9
1.3	10	0.5	1.1	1.6	2.1	2.7	3.2	3.7
2	13	0.8	1.6	2.4	3.2	4	4.8	5.6
2.7	20	1.1	2.2	3.2	4.3	5.3	6.4	7.5
3.3	25	1.3	2.7	4	5.3	6.7	8	9.3
4	30	1.6	3.2	4.8	6.4	8	9.6	12
5.3	40	2.1	4	6.4	8.5	11	13	15
6.7	50	2.7	5.4	8	10.7	13	16	19
8	60	3.3	6.4	9.6	12.8	16	19	22
9.4	70	3.7	7.5	11.2	15	19	22	26
10.7	80	4.3	8.5	13	17	21	26	30
12	90	5	10	14.5	19	24	29	34
13.4	100	5.5	11	16	21	27	32	37
16.7	125	7	13	20	27	33	40	47
20	150	8	16	24	32	40	48	56
23.4	175	9	18	28	37	47	56	65
26.7	200	11	21	32	43	53	64	75
33.7	250	13	27	40	53	67	80	93
40	300	16	32	47	64	80	96	112
53.4	400	21	43	64	85	107	128	149
66.8	500	27	53	80	107	133	160	187

KW TO HEAT IN 1 HOUR

FOR WATER

Quick estimates for other volumes:

$$KW = \frac{\text{Gal/Hr} \cdot 8.34 \cdot \text{Temperature Rise (°F)}}{3412}$$

$$\text{GAL/HR} = \frac{KW \cdot 3412}{8.34 \cdot \text{Temperature Rise (°F)}}$$

Table 2: To Heat Air

Ft ³ /Min. CFM	TEMPERATURE RISE (°F)											
	50"	100"	150"	200"	250"	300"	350"	400"	450"	500"	600"	
100	1.7	3.3	5.0	6.7	8.3	10.0	11.7	13.3	15.0	16.7	20.0	
200	3.3	6.7	10.0	13.3	16.7	20.0	23.3	26.7	30.0	33.3	40.0	
300	5.0	10.0	15.0	20.0	25.0	30.0	35.0	40.0	45.0	50.0	60.0	
400	6.7	13.3	20.0	26.7	33.3	40.0	46.7	53.3	60.0	66.7	80.0	
500	8.3	16.7	25.0	33.3	41.7	50.0	58.3	66.7	75.0	83.3	100.0	
600	10.0	20.0	30.0	40.0	50.0	60.0	70.0	80.0	90.0	100.0	120.0	
700	11.7	23.3	35.0	46.7	58.3	70.0	81.7	93.3	105.0	116.7	140.0	
800	13.3	26.7	40.0	53.3	66.7	80.0	93.3	106.7	120.0	133.3	160.0	
900	15.0	30.0	45.0	60.0	75.0	90.0	105.0	120.0	135.0	150.0	180.0	
1000	16.7	33.3	50.0	66.7	83.3	100.0	116.7	133.3	150.0	166.7	200.0	
1100	18.3	36.7	55.0	73.3	91.7	110.0	128.3	146.7	165.0	183.3	220.0	
1200	20.0	40.0	60.0	80.0	100.0	120.0	140.0	160.0	180.0	200.0	240.0	

KW TO HEAT IN 1 HOUR

Use the maximum anticipated airflow. Table 2 and below equations assume insulated duct, negligible heat loss, 70° inlet air and 14 PSIA.

FOR AIR

$$KW = \frac{\text{CFM} \cdot \text{Temperature rise (°F)}}{3000}$$

FOR COMPRESSED AIR

$$KW = \frac{\text{CFM} \cdot \text{Density} \cdot \text{Temperature Rise (°F)}}{228}$$

Table 4: To Heat Oil

FT ³ /HR	GAL /HR	TEMPERATURE RISE (°F)						
		50'	100'	200'	300'	400'	500'	
.5	3.74	0.3	0.5	1	2	2	3	
1	7.48	0.5	1	2	3	4	6	
2	14.96	1	1	2	4	6	11	
3	22.25	2	3	6	9	12	16	
4	29.9	2	4	8	12	16	22	
5	37.4	3	4	9	15	20	25	
10	74.8	5	9	18	29	40	52	
15	112.5	7	14	28	44	60	77	
20	149.6	9	18	37	58	80	102	
25	187	11	22	46	72	100	127	
30	222.5	13	27	56	86	120	151	
35	252	16	31	65	100	139	176	
40	299	18	36	74	115	158	201	
45	336.5	20	40	84	129	178	226	
50	374	22	45	93	144	197	252	
55	412	25	49	102	158	217	276	
60	449	27	54	112	172	236	302	
65	486	29	58	121	186	255	326	
70	524	32	62	130	200	275	350	
75	562	34	67	140	215	294	375	

KW TO HEAT IN 1 HOUR

FOR OIL

Quick estimates for other volumes:

$$KW = \frac{\text{Gallons} \cdot \text{Temperature Rise (°F)}}{800 \cdot \text{Process Start-up Time (hrs)}}$$

Add 5% for uninsulated tanks.



LIQUIDS

Table 5

Properties of Materials

Substance	Specific heat Btu/lb-°F	Heat of vaporization Btu/lb	Boiling point °F	Density- weight in lbs/ft ³	Thermal conductivity Btu-in/hr-ft ² -°F	Substance	Specific heat Btu/lb-°F	Heat of vaporization Btu/lb	Boiling point °F	Density- weight in lbs/ft ³	Thermal conductivity Btu-in/ hr-ft ² -°F
Acetic Acid, 100%	.48	175	245	65.4	1.14	Perchloroethylene	.21	90	250	101.3	***
Acetone	.514	225	133	49	1.15	Petroleum Products:					
Allyl Alcohol	.665	293	207	55	***	Asphalt	.42	***	***	62.3	5.04
Ammonia, 100%	1.1	589	-27	47.9	3.48	Benzene	.42	170	175	56	1.04
Amyl Alcohol	.65	216	280	55	***	Fuel Oils:					
Aniline	.514	198	63	64.3	1.25	Fuel Oil #1 (Kerosene)	.47	86	••440±	50.5	1.01
Arochlor Oil	.28	***	650	89.7	***	Fuel Oil #2	.44	***	***	53.9	.96
Brine-Sodium Chloride, 25%	.786	730	220	74.1	2.88	Fuel Oil Medium #3,#4	.425	67	••580±	55.7	.918
Butyl Alcohol	.687	254	244	45.3	***	Fuel Oil Heavy #5,#6	.41	***	***	58.9	.852
Butyric Acid	.515	***	345	50.4	***	Gasoline	.53	116	••280±	41-43	.936
Carbon Tetrachloride	.21	***	170	98.5	***	Machine/Lube Oils:					
Corn Syrup, Dextrose	.65±	***	231	87.8	***	SAE 10-30	.43	***	***	55.4	***
Cottonseed Oil	.47	***	***	59.2	1.20	SAE 40-50	.43	***	***	55.4	***
Ether	.503	160	95	46	.95	Napthalene	.396	103	424±	54.1	***
Ethyl Acetate	.475	183.5	180	51.5	***	Paraffin Melted (150°F+)	.69	70	572	56	1.68
Ethyl Alcohol, 95%	.60	370	***	50.4	1.30	Propane (Compressed)	.576	***	-48.1	.13	1.81
Ethyl Bromide	.215	108	101	90.5	***	Toluene	.42	***	***	53.7	1.032
Ethyl Chloride	.367	166.5	54	57	***	Transformer Oils	.42	***	***	56.3	.9
Ethyl Iodide	.161	81.3	160	113	***	Phenol (Carbolic Acid)	.56	***	346	66.6	***
Ethylene Bromide	.172	83	270	120	***	Phosphoric Acid 10%	.93	***	***	65.4	***
Ethylene Chloride	.299	139	240	71.7	***	Phosphoric Acid 20%	.85	***	***	69.1	***
Ethylene Glycol	.55	***	387	70.0	***	Polyurethane Foam					
Fatty Acid, Aleic	.7±	***	547	55.4	1.10	Components:					
Fatty Acid, Palmitic	.653	***	520	53.1	.996	Part A Isocyanate	.6	***	***	77	1.14
Fatty Acid, Stearic	.550	***	721	52.8	.936	Part B Polyol Resin	.7	***	***	74.8	1.32
Formic Acid	.525	216	213	69.2	***	Potassium (1000°F)	.18	893	1400	44.6	260.4
Freon 11	.208	***	74.9	92.1	.60	Propionic Acid	.56	177.8	286	61.8	***
Freon 12	.232	62	-21.6	81.8	.492	Propyl Alcohol	.57	295.2	208	50.2	***
Freon 22	.300	***	-41.36	74.53	.624	Sea Water	.94	***	***	64.2	***
Fruit, Fresh (Avg)	.88	***	***	50-60	***	Sodium (1000°F)	.30	1810	1638	51.2	580
Glycerine	.58	***	556	78.7	1.97	Sodium Hydroxide					
Heptane	.49	137.1	210	38.2	***	(Caustic Soda)					
Hexane	.6	142.5	155	38.2	***	30% Sol	.84	***	***	82.9	***
Honey	.34	***	***	***	***	50% Sol	.78	***	***	95.4	***
Hydrochloric Acid 10%	.93	***	221	66.5	***	Soybean Oil	.24-.33	***	***	57.4	***
Lard	.64	***	***	57.4	***	Starch	***	***	***	95.4	***
Linseed Oil	.44	***	552	57.9	***	Sucrose, 40% Sugar Syrup	.66	***	214	73.5	***
Maple Syrup	.48	***	***	***	***	Sucrose, 60% Sugar Syrup	.74	***	218	80.4	***
Mercury	.033	117	675	845	59.6	Sulfur, Melted (500°F)	.24	120	832	112	***
Methyl Acetate	.47	176.5	133	54.8	***	Sulfuric Acid 20%	.84	***	218	71	***
Methyl Chloroform	.26	95	165	82.7	***	Sulfuric Acid 60%	.52	***	282	93.5	2.88
Methylene Chloride	.288	142	104	82.6	***	Sulfuric Acid 98%	.35	219	625	114.7	1.80
Milk 3.5%	.90	***	***	64.2	***	Trichloroethylene	.23	103	188	91.3	.84
Molasses	.60	***	220±	87.4	***	Trichloro-Trifluoroethane	.21	63	118	94.6	***
Nitric Acid, 7%	.92	918	220	64.7	***	Turpentine	.42	133	319	54	***
Nitric Acid, 95%	.5	207	187	93.5	***	Vegetable Oil	.43	***	***	57.5	***
Nitrobenzene	.35	142.2	412	***	***	Water	1.00	965	212	62.5	4.08
Olive Oil	.47	***	570	58	***	Xylene	.411	149.2	288	53.8	***

GASES & VAPORS

Table 6

- At or near room temperature.
- Average value shown boils at various temperatures with the distillation range for the material.

Substance	Thermal conductivity Btu-in/hr-ft ² - °F *	Specific heat at constant pressure Btu/lb-°F *	Density lbs/ft ³ *	Specific gravity relative to air	Substance	Thermal conductivity Btu-in/hr-ft ² - °F *	Specific heat at constant pressure Btu/lb-°F *	Density lbs/ft ³ *	Specific gravity rela- tive to air
Acetylene (ethyne)	.129	.35	.0682	.907	Hydrogen Sulphide	.091	.243	.0895	1.19
Air	.18	.24	.075	1.000	Methane	.21	.593	.0417	.554
Ammonia	.16	.523	.0448	.596	Methyl Chloride24	.1342	1.785
Argon	.12	.124	.1037	1.379	Natural Gas56	.0502	.667
Butane	.0876	.395	.1554	2.067	Nitric Oxide	.1656	.231	.078	1.037
Carbon Dioxide	.12	.199	.115	1.529	Nitrogen	.19	.247	.0727	.967
Carbon Monoxide	.18	.248	.0727	.967	Nitrous Oxide	.1056	.221	.1151	1.53
Chlorine	.06	.115	.1869	2.486	Oxygen	.18	.217	.0831	1.105
Ethane386	.0789	1.049	Propane393	.1175	1.562
Ethylene	.1212	.40	.0733	.975	Propane (propylene)358	.1091	1.451
Helium	1.10	1.25	.0104	.1381	Sulphur Dioxide	.07	.154	.1703	2.264
Hydrogen Chloride191	.0954	1.268	Water vapor at 212°F	.16	.482	.037	.489
Hydrogen	.13	3.42	.0052	.0695					

* At 70° & atmospheric pressure (14.7 PSIA) Natural gas values are representative. Specific contents of sampling are required for exact characteristics.

METAL & NON-METALLIC SOLIDS

Table 7

Substance	Specific Heat	Heat of fusion Btu/lb	Melting point °F	*Density-weight in lbs/ft ³	*Thermal conductivity Btu/in hr ft ² °F	Thermal expansion in/in/°F x 10 ⁻⁶	Substance	Specific Heat	Heat of fusion Btu/lb	Melting point °F	*Density-weight in lbs/ft ³	*Thermal conductivity Btu/in hr ft ² °F	Thermal expansion in/in/°F x 10 ⁻⁶
Aluminum 2024-T3	.24	167	935	173	1344	12.6	Paper	.45	***	***	58.8	.82	***
Aluminum 1100-0	.24	169	1190	169	1536	13.1	Paraffin	.69	63	133	55.3	1.6	***
Antimony	.049	69	1166	423	131	***	Pitch (Hard)	***	300±	83	***	***	***
Asbestos Cement Board	.25±	***	***	121	5.2	***	Plastics:						
Asphalt	.40	40	250	65	1.2	***	ABS	.35	***	***	69-76	1.32	***
Bakelite Resin, Pure	.3-4	***	***	74-81	***	***	Acrylic	.34	***	***	69-74	1.0	***
Barium	.068	***	1562	225	***	***	Cellulose Acetate	.3-5	***	***	76-83	1.2-2.3	***
Beeswax	***	75	144	60.5	1.67	***	Cellulose Acetate Butyrate	.3-4	***	***	74	1.2-2.3	***
Beryllium	.052	***	2345	113.5	***	***	Epoxy	.25-.3	***	***	66-88	1.2-2.4	***
Bismuth	.031	23	520	612	59	***	Fluoroplastics	.28	***	***	131-150	1.68	***
Boron	.309	***	4172	144	***	***	Nylon	.3-5	***	***	67-72	1.68	***
Brass, Yellow	.096	***	1710	529	828	11.2	Phenolic	.35	***	***	85-124	1.02	***
Brickwork & Masonry	.220	***	***	131	3-7	3-6	Polycarbonate	.3	***	***	74-78	1.38	***
Bronze (75% Cu; 25% Sn)	.082	75	1832	541	180	***	Polyester	.2-.35	***	***	66-92	4-5	***
Cadmium	.055	23.8	610	540	660	***	Polyethylene	.54	***	***	57-60	2.3	94.0
Calcium	.149	140	1564	96.7	912	***	Polyimides	.27-.31	***	***	90	2.5-6.8	***
Calcium Chloride	.17	72	1422	157	***	***	Polypropylene	.46	***	***	55-57	1.72	***
Carbon	.280	***	6700	138	173	***	Polystyrene	.32	***	***	66	.7-1.0	33-34
Cement, Portland							Polyvinyl Chloride Acetate	.2-.3	***	***	72-99	.84-1.2	***
Loose	.19	***	***	94	2.04	***	Platinum	.035	49	3225	1339	492	4.9
Cerafelt Insulation @ 1000°F	25	***	3	***	1.22	***	Porcelain	.26	***	***	145-155	6-10	***
Ceramic Fiber	.27	***	***	4-10	***	***	Potassium	.058	26.2	146	750	720	***
Chalk	.215	***	***	112-175	5.76	***	Potassium Chloride	.17	***	1454	124	***	***
Chromium	.11	***	2822	450	484	***	Potassium Nitrate	.26	***	633	132	***	***
Clay	.224	***	3160	90	9	***	Quartz	.26	***	***	138	***	***
Coal	.32	***	***	80	11	***	Rhodium	.059	***	3570	776	636	***
Coal Tar	.35-.45	***	***	78	***	***	Rubber	.44	***	***	76.0	1.1	340
Cobalt	.099	115.2	2696	554	499	***	Rubber, Synthetic	.40	***	***	58	1.0	***
Coke	.265	***	***	62-88	***	***	Silicone Rubber	.45	***	***	78	***	***
Concrete, Cinder	.16	***	***	100	5.3	***	Silicon	.162	***	2570	14.5	***	***
Concrete, Stone	.156	***	***	144	9.5	***	Silver	.057	38	1760	665	2904	10.8
Copper	.095	91.1	1981	556	2688	9.8	Sodium	.295	49.3	207	60	972	***
Cork	.50	***	***	13.5	.36	***	Solder (50%Pb-50%Sn.)	.051	17	420	558	336	13.1
Cotton (Flax, Hemp)	.31	***	***	92.4	.41	***	Steatite	.20	***	***	162	17.5-23	4.5-5.5
Delrin	.350	***	***	88.1	1.6	45.0	Steel Mild	.122	***	2760	491	456	6.7
Firebrick, Fireclay	.243	***	2900	137-150	6.6	***	Steel S. 304	.12	***	2550	494	105.6	9.6
Firebrick, Silica	.258	***	3000	144-162	7.2	***	Steel S. 430	.11	***	2650	475	150	6.0
Glass	.20	***	2200	164	5.4	5.0	Sulfur	.175	17	246	130	1.9	36.0
Gold	.032	29.0	1945	1206	2028	7.9	Sugar	.30	***	320	105	***	***
Granite	.192	***	***	160-175	13-28	***	Tallow	***	90±	60.0	***	***	***
Graphite	.20	***	***	130	1.25	***	Tantalum	.035	***	5425	1036	372	3.6
Ice	.53	144	32	56.0	11	28.3	Teflon	.25	***	***	135	1.7	55.0
Incoloy 800	.13	***	2500	501	97	7.9	Tin, Solid	.065	26.1	450	454	432	13.0
Inconel 600	.126	***	2500	525	109	5.8	Titanium 99.0%	.13	***	3035	283	111.6	4.7
Invar (36%Ni)	.126	***	2600	506	73	***	Tungsten	.0321	79	6170	1200	1130	2.5
Iron, Cast	.12	***	2150	449	396	6.0	Type Metal (85%Pb-13%Sb.)	.040	14±	500	669	180	***
Iron, Wrought	.12	***	2800	480	432	***	Uranium	.028	***	3075	1170	193.2	***
Isoprene, Rubber	.48	***	***	58	1.0	***	Vinyl	.3-5	***	***	79.5	.8-20	28-100
Lead, Solid	.032	11.3	620	708	240	16.4	Wood, Pine	.45±	***	***	34	.9	***
Limestone	.217	***	***	130-175	3.6-9	***	Wood, Oak	.57	***	***	50	1.1	***
Lithium	.79	59	367	367	516	***	Zirconium	.066	108	3350	400	145	3.2
Manganese	.115	116	2268	463	80.6	***	Zinc	.096	43.3	264	445	7.40	22.1
Magnesium	.27	160	1202	109	1092	14.0							
Magnesia, 85%	.222	***	5070	19	***	***							
MgO (Compacted)	.209	***	***	194	20	7.7							
Mercury	.033	5	-38	844	60.8	***							
Mica	.21	***	***	176	3.0	18.0							
Molybdenum	.061	126	4750	638	***	***							
Monel 400	.11	***	2370	551	151	6.4							
Nickel 200	.12	133	2615	555	468	5.8							
Nichrome (80% Ni - 20% Cr)	.11	***	2550	522	104.4	7.3							

* At or near room temperature.

- ◆ To convert to Kg/m³ multiply by 16.02.
- ◆ To convert to Kj/Kg multiply by 2.326.
- ◆ To convert to Kj/Kg - °C multiply Btu/lb - °F by 4.187.
- ◆ To convert to W/m - °C multiply Btu - in/hr - ft² by 0.1442.



METALS IN LIQUID STATE

Table 8

Substance	Specific Heat Btu/lb-°F	Heat of fusion Btu/lb	Melting point °F	Temperature°F	Density - weight lbs/ft ³	Thermal conduc- tivity Btu- in hr ft ² -°F
Aluminum	.26	173	1220.4	1220	148.6	***
	.26	***	***	1292	147.7	717
	.26	***	***	1454	***	842
Bismuth	.034					
	@ 520°F	21.6	520	572	626.2	119
	.0354	***	***	752	618.7	107.4
Cadmium	.0376	***	***	1112	603.1	107.4
	.0632	23.8	609	626	500	***
	.0632	***	***	662	498.8	307.7
Gold	.0632	***	***	680	***	305
	.0632	***	***	752	495	***
	.0355	26.9	1945	2012	1076	***
Lead	.038	10.6	621	700	655.5	111.6
	.037	***	***	932	648.7	107.4
Lithium	1.0	284.4	354	392	31.7	262
	1.0	***	***	752	31	***
Magnesium	.317	148	1204	1204	98	***
	***	***	***	1328	94.3	***
	***	***	***	1341	***	***
	.321	***	***	***	***	***
Mercury	.0334	5	-38	32	***	57
	.03279	***	***	212	833.6	***
	***	***	***	320	***	81
	.3245	***	***	392	818.8	***
Potassium	.1901	26.3	147	300	50.6	312
	.1826	***	***	752	46.6	277.5
Silver	.0692	44.8	1761	1761	580.6	***
	.0692	***	***	1832	578.1	***
	.0692	***	***	2000	574.4	***
Sodium	.331	48.7	208	212	57.9	596.5
	.320	***	***	400	56.2	556.8
	.301	***	***	752	53.3	493.8
Solder .5 Sn. .5Pb	.0556	17	421	***	***	***
	.0584	28	375	***	***	***
Tin	.058	26.1	449	482	***	***
	***	***	***	768	426.6	***
	***	***	***	783	***	229.3
Zinc	.12	43.9	787	787	432	***
	***	***	***	932	***	400.6
	.177	***	***	1112	425	394.8

MATERIAL EMISSIVITIES/Non-METALS

Substance	Specific heat Btu/lb-°F	Emissivity
Asbestos	0.25	Most non-metals: 0.90
Asphalt	0.40	
Brickwork	0.22	
Carbon	0.20	
Glass	0.20	
Paper	0.45	
Plastic	0.2-0.5	
Rubber	0.40	
Silicon Carbide	0.20-0.23	
Textiles	***	
Wood, Oak	0.57	

Material Emissivities

Heat Loss Factors

Table 9

MATERIAL EMISSIVITIES/METALS

Substance	Specific heat Btu/lb-°F	Emissivity		
		Polished surface	Medium oxide	Heavy oxide
Aluminum	0.24	0.09	0.11	0.22
Blackbody	***	***	0.75	1.00
Brass	0.10	0.04	0.35	0.60
Copper	0.10	0.04	0.03	0.65
Incoloy 800	0.12	0.20	0.60	0.92
Inconel 600	0.11	0.20	0.60	0.92
Iron, Cast	0.12	***	0.80	0.85
Lead, solid	0.03	***	0.28	***
Magnesium	0.23	***	***	***
Nickel 200	0.11	***	***	***
Nichrome, 80-20	0.11	***	***	***
Solder, 50-50	0.04	***	***	***
Steel:				
mild	0.12	0.10	0.75	0.85
stainless 304	0.11	0.17	0.57	0.85
stainless 430	0.11	0.17	0.57	0.85
Tin	0.056	***	***	***
Zinc	0.10	***	0.25	***

HEATER LIFE ESTIMATION

The table below shows the estimated life of a heater internal element (i.e. Tophet A, 80 Ni 20 Cr wire) at various temperatures. The life of a heater is a function of maximum temperature and temperature cycling. Higher temperatures means shorter heater life. Life of cartridge heaters with MGO insulation are limited to the wire oxidation rate. Silicone rubber and mica insulated heaters have life limits associated with the temperature limits of the insulating materials. (Note: Allowances must be made for heater sheath temperature vs. heater element temperature.)

ELEMENT TEMP. (°F)	ESTIMATED LIFE
1500°F	3-1/2 years
1600°F	1 year
1700°F	4 months
1800°F	1-1/2 months
1900°F	14 days
2000°F	7 days



Guidelines for Watt Density & Operation Temperature

Table 10

Material to be heated	Max. operating temperature °F	Max. watt density (W/in ²)	Sheath material	Material to be heated	Max. operating temperature °F	Max. watt density (W/in ²)	Sheath material
Acid Solution (Mild)				Fuel Oils cont.			
Acetic	180	40	C-20, Quartz	Grade 4 & 5			
Boric	257	40	Quartz	(residual)	200	13	Steel
Carbonic	180	40	***	Grades 6 & bunker c			
Chromic	180	40	C-20, Quartz	(residual)	160	8	Steel
Citric	180	23	316 S.S.	Gasoline	300	23	Steel
Fatty Acids	150	20	316 S.S.	Gelatin, Liquid	150	23	Stainless Steel
Lactic	122	10	316 S.S.	Solid	150	5	Stainless Steel
Malic	122	10	316 S.S.	Glycerine	500	10	Incoloy
Nitric	167	20	Quartz	Glycerol	212	23	Incoloy
Phenol - 2-4				Grease, Liquid	***	23	Steel
Disulfonic	180	40	316 S.S.	Solid	***	5	Steel
Phosphoric	180	23	Quartz	Heat Transfer Oils	500	23	Steel
Phosphoric (Aerated)	180	23	Stainless Steel	600	15	Steel	
Proponic	180	40	Copper	Hydrazine	212	16	Stainless Steel
Tannic	167/180	23/40	Quartz	Hydrogen	C/F	***	Incoloy
Tartaric	180	40	316 S.S.	Hydrogen Sulfide	C/F	***	316 S.S.
Acetaldehyde	180	10	Copper	Linseed Oil	150	50	Steel
Acetone	130	10	Incoloy	Lubrication Oil			
Air	C/F	***	Incoloy	SAE 10, 90-100			
Alcyl Alcohol	200	10	Copper	SSU @ 130°F	250	23	Steel
Alkaline Solutions	212	40	Steel	SAE 20, 120-185			
Aluminum Acetate	122	10	316 S.S.	SSU @ 130°F	250	23	Steel
Aluminum Potassium Sulfate	212	40	Copper	SAE 30, 185-255			
Ammonia Gas	C/F	***	Steel	SSU @ 130°F	250	23	Steel
Ammonium Acetate	167	23	Incoloy	SAE 40, -80			
Amyl Acetate	240	23	Incoloy	SSU @ 210°F	250	13	Steel
Amyl Alcohol	212	20	Stainless Steel	SAE 50, 80-105			
Aniline	350	23	Stainless Steel	SSU @ 210°F	250	13	Steel
Asphalt	200-500	4-10	Steel	Magnesium Chloride	212	40	C-20, Quartz
Barium Hydroxide	212	40	316 S.S.	Manganese Sulfate	212	40	Quartz
Benzene, liquid	150	10	Copper	Methanol gas	C/F	***	Stainless Steel
Butyl Acetate	225	10	316 S.S.	Methylchloride	180	20	Copper
Calcium Bisulfate	400	20	316 S.S.	Mineral Oil	200	23	Steel
Calcium Chloride	200	5-8	Quartz	400	16	Steel	
Carbon Monoxide	***	23	Incoloy	Molasses	100	4-5	Stainless Steel
Carbon Tetrachloride	160	23	Incoloy	Naptha	212	10	Steel
Caustic Soda 2%	210	48	Incoloy	Oil Draw Bath	600	23	Steel
10%	210	25	Incoloy	Oils (see specific type)	400	24	Steel
75%	180	25	Incoloy	Paraffin or Wax (liquid state)			
Citrus Juices	185	23	316 S.S.	Perchloroethylene	150	16	Steel
Degreasing Solution	275	23	Steel	Potassium Chlorate	200	23	Steel
Dextrose	212	20	Stainless Steel	Potassium Chloride	212	40	316 S.S.
Dowtherm A				Potassium Hydroxide	212	40	316 S.S.
1 ft. sec. or more non-flowing	750	23	Steel	Monel	160	23	Monel
Dowtherm E	750	10	Steel	Soap, liquid	212	20	Stainless Steel
Dyes & Pigments	400	12	Steel	Sodium Acetate	212	40	Steel
Electroplating Baths	212	23	Stainless Steel	Sodium Cyanide	140	40	Stainless Steel
Cadmium	180	40	Stainless Steel	Sodium Hydride	720	28	Incoloy
Copper	180	40	Quartz	Sodium Hydroxide	(See Caustic)		Soda
Dilute Cyanide	180	40	316 S.S.	Sodium Phosphate	212	40	Quartz
Potassium Cyanide	180	40	Quartz	Steam, flowing	300	10	Incoloy
Rochelle Cyanide	180	40	Stainless Steel	500	5-10	Incoloy	
Sodium Cyanide	180	40	Stainless Steel	700	5	Incoloy	
Ethylene Glycol	300	30	Steel	700	10	Incoloy	
Formaldehyde	180	10	Stainless Steel	Sulfur, Molten	600	5	Incoloy
Freon gas	300	2-5	Steel	Terminols	500	23	Steel
Fuel Oils:				600	23	Steel	
Grade 1 & 2 (distillate)	200	23	Steel	Toluene	650	15	Steel
				212	23	Steel	
				150	23	Steel	
				300	20	Stainless Steel	
				Vegetable Oil & Shortening	400	30	Stainless Steel
				Water (process)	212	60	S.S., Incoloy

Note: C-20 designates Carpenter Stainless #20.
C/F = Consult Factory.



Corrosion Resistance of materials

Table 11

Compound	SUGGESTED METAL SHEATH									Compound	SUGGESTED METAL SHEATH								
	Iron & Steel	Cast Iron NI Resist	300 Series Stainless	Monel	Inconel/Incoloy	Copper	Lead	Aluminum	Nickel		Iron & Steel	Cast Iron NI Resist	300 Series Stainless	Monel	Inconel/Incoloy	Copper	Lead	Aluminum	Nickel
Acetic Acid, Crude	X	C	F	F	C	F	X	F	F	Deoxylle			A						
Pure		X		A	C	F	F	A	F	Diphenyle 300°-350°	A								
Vapor		X		F	C	F	X	C	F	Di Sodium Phosphate									
150 PSI; 400°F				F	C	F	X	C	F	25% 180°F	A								
Acetone	C	F	A	A	A	A	A	F	A	Diversey No. 99	A								
Alboloy Process	A									Dowtherm	A								
Alodine 200°F			A-347							Ethers	A			A	A	A	A	A	
Aluminum Sulphate	X	C	F	F		F	A	C	C	Ethyl Chloride	A		A	A		A			A
Ammonia Gas, Cold	A	A	A	A		C	A	A		Ethylene Glycol 300°F.			A	A					A
Hot	C	C	C	C		X	X			Ferric Chloride	X	X	X	X	X	X	X	X	X
Ammonia and Oil	A									Ferric Sulphate	X	X	F-304	X	C	X	A	X	X
Ammonium Chloride	C	A	F	F		X	A	X	F	A-316			A	A					
Ammonium Hydroxide	A	A	A	C	A	X	A	F		Formaldehyde	F	F	A	A	A	F	X	F	
Ammonium Nitrate	A	C	A	C		X	X	F		Formic Acid	X		F	C	C	F	X	X	C
Ammonium Sulphate	A	A	A	A		F	A			Freon	C	A	C	A		A	A	A	
Amyl Alcohol				A		A				Fuel Oil	A		A	A		A	A		
Anhydrous Ammonia	A					X				Fuel Oil, Acid	C		C	A		C	A		
Aniline, Aniline Oil	A		A	A		X		X		Gasoline, Sour	C	C	A	A	A	C	A	C	
Aniline, Dyes			A	A						Gasoline, Refined	A	A	A	A	A	A	A	A	
Anodizing Solution 10%	C		A							Glycerin, Glycerol	A	A	A	A		F	A	A	
Chromic Acid 96°F										Holdsens 310A Tempering Bath									A
Sulphuric Acid 70°F							A			Houghtons Mar Tempering Salts	C								C
Sodium Hydroxide Alkaline	A									Hydrochloric Acid <150°F	X	X	X	C		X	F	X	C
Nigrosine Black Dye			A						F	>150°F	X	X	X	C		X	X	X	C
Nickel Acetate			A			C			F	Hydrofluoric Acid, Cold <65%	X	X	X	F		C	F	X	X
Barium Chloride			F-304							>65%	F		X	A		F	C	X	
Barium Hydroxide			A			X	X	X	A	Hot <65%	X		X	C		X	X	X	X
Barium Sulphide			A	A		X	A			>65%	C		X	A		F	X	X	
Bleaching Solution				A					F	Hydrogen Peroxide	X	X	A	F	A	X	F	A	F
1 1/2 lb. Oxalic Acid per										Iridite 1-Part and 5-Parts								A	
Gallon of H ₂ O at 212°F										Water @ 200°F									
Bonderizing	C	F	A							Isopropanol	C			A		F			
Cadmium Plating				A						Kerosene	A		A	A	A	A	A		
Carbolic Acid, Phenol	C	C	A	A	A	X	A	A		Kolene									A
Carbon Dioxide, Dry	A	A	A	A	A	A	A	A		Lacquer Solvents	C	A	A	A		C		A	
Wet	F	C	A	A	A	F	X	F	Lard	F									
Carbon Tetrachloride	C	C	C	A	A	C	F	C	Linseed Oil	A		A	A	A	A	A	A		
Castor Oil	A		A	A	A			A	Magnesium Chloride	F	F	F	F		F	X	X	F	
Chloroacetic Acid	X		X			X	X	X	F	Magnesium Hydroxide	A	A	A	A		X		X	A
Cholorine, Dry	A	A	A	A		A	A	A	Magnesium Sulphate	A	A	A	A		A		C		
Wet	X	X	X	X		X	F	X	Mercuric Chloride	C	C	X	X	X	X		X	X	
Chromic Acid	C	C	A	F	C	X	A	X	Mercury	A	A	A	A	A	X		X		
Chrome Plating							A		Methyl Alcohol, Methanol	A		A	A		A	A	A		
Citric Acid	X	C	A	A	A	A	A	A	Methyl Chloride	A		A	A		A	A	A	A	
Cobalt Acetate 130°F				A	A				Mineral Oils	A		A	A	A	A	A	A		
Coconut Oil				F				A	Naphthalene	A									
Copper Chloride	F		X	F		C	A	X	Nickel Chloride			F	C		X		X		
Copper Cyanide	A								Nickel Plating, Bright								A		
Copper Plating	A								Nickel Plating, Dull								A		
Copper Sulphate	X	C	A	A	A	C	A	X	Nickel Sulphate			A	C	X	X		X		
Creosote	A	A	A	A		A		A	Nitric Acid, Crude	X		C	X	X	X	X	C	X	
Deoxidine			A						Concentrated	X		F	X	X	X	X	A	X	
									Diluted	X		A	X	X	X	X	X	X	
									Nitrobenzene	A		A			F				

RESISTANCE RATINGS:

A = Good

F = Fair

C = Conditional*

X = Unsuitable

Corrosion Resistance of materials cont.

Table 11

Compound	SUGGESTED METAL SHEATH								Compound	SUGGESTED METAL SHEATH									
	Iron & Steel	Cast Iron NI Resist	300 Series Stainless	Monel	Inconel/Incoloy	Copper	Lead	Aluminum		Nickel	Iron & Steel	Cast Iron NI Resist	300 Series Stainless	Monel	Inconel/Incoloy	Copper	Lead	Aluminum	Nickel
Oakite No. 20	A									Steam <500°F	A	A	A	A	A	A	C	A	A
Oakite No. 23	A									500-1000°F	C	A	C	A	C	X	C	C	C
Oakite No. 24	A									>1000°F	X	A	X	A	X		X	X	
Oakite No. 30	A									Stearic Acid	C	C	A	A	A	C	A	C	A
Oakite No. 32										Sulphur	A	C	F	X	A	X		A	X
Oakite No. 33			A-347							Sulphuric Acid <10% Cold	X		F	C		C	A	C	X
Oakite No. 36										Hot	X		F-316 X-304	C		X	A	C	X
Oakite No. 51	A									10-75% Cold	X		X-304 F-316	C		X	A	C	C
Oakite No. 90 @ 180°F	A									Hot	X		X	C		X	A	X	X
Oleic Acid	C	C	A	A	A	X	X	A	A	75-95% Cold	C		A	C		X	A	C	C
Oxalic Acid	C	C	C	A		C	X	A		Hot	F		X	C		X	A	X	X
Paraffin	A									Fuming	C	F	C-304 F-316	X		X	A	C	X
Parkerizing	C	F	A							Sulphurous Acid	A		C-316 X-304	X		C	A	C	X
Perchloroethylene			A							Tannic Acid			F	A		A	X	X	A
Permachlor			A							Tar	A		A		A		A		
Petroleum Oils, Crude <500°F	A	A	A	C		C	C	A	C	Tartaric Acid			C-304 A-316	C			A	A	C
>500°F	A	A	A	X		X	X	A	X	Tetrachlorethyene	A								
>1000°F	X		C	X		X	X	X	X	Thermail Granodine	F								
Phenol 85%, 120°F	C		A							Therminall Fr. 1-8-1/2 W/in ² @ 640°F	A								
Phosphoric Acid, Crude	C		C	X		X	C	X	C	Tin Plating									A
Pure <45%	X		A	F		F	A	C	C	Toluene	A			A			A	A	
>45% Cold	X		A	F		F	A	X	C	Triad Solvent	C								
Hot	X		X-304 C-316	C		C	X	X		Trichloroethylene	C	C	C	A		C	F	C	
Photo Fixing Bath			A	C						Turco No. 2623	A								
Picric Acid Water Solution	C		A	C		X	X	X	X	Turpentine	C	A	A	A		C	A	A	
Potassium Chloride	A	A	A	A		A	A	C	A	Urea Ammonia Liquor 48°F	A								
Potassium Cyanide	A		A	A		X	X	X		Vegetable Oil			A						
Potassium Dichromate 208°F			A-347							Vinegar	C		F-304 A-316	A				C	
Potassium Hydroxide	C	A	F	A		X	X	X	A	Water, Acid Mine	X	C	A	X		C	C	C	C
Potassium Sulphate	A	A	F	A		A	A	A	A	Containing Oxidizing Salts									
Prestone 350°F	A			A						No Oxidizing Salts	C	A	X	A					A
R5 Bright Dip for Copper			A-316							Water, Fresh	C	A	A	A	A	A	A	A	
Polish @ 180°F										Distilled, Lab Grade	X	X	A	C	A	X	X	A	A
Soap Solutions	A	A	A	A		C	A			Return Condensate	A	A	A	A	A	A	A	A	
Sodium Carbonate <20%	A									Water, Sea Water	C	A	F	A	F	C	A	X	
Sodium Chloride	A	A	F-304 A-316	A	A	F	A	X	A	Whiskey and Wines	X	C	F-304 A-316	A	A	A			
Sodium Cyanide	A	C	A-316	F		X	X	X		X-Ray Solution			A						
Sodium Hydroxide	A	A	F	A	A	X	F	X	A	Zinc Chloride	C	C	X	A		X	A	X	
Sodium Hypochlorite	X	C	X	C		C	X	X	C	Zinc Plating	A								
Sodium Nitrate	A	A	F-304 A-316	A	A	F	A	A	A	Zinc Sulphate	C	A	A	A	A	X		C	
Sodium Peroxide	C	A	A	A				A	A										
Sodium Silicate	A	A	A-316	A		C	X	X	A										
Sodium Sulphate	A	A	A	A	A	A	A	C	A										
Sodium Sulphide	A	A	A	F	A	X	A	X	F										
Soybean Oil			A																

RESISTANCE RATINGS:

A = Good

F = Fair

C = Conditional*

X = Unsuitable

*Conditional: Performance is dependent upon specific application conditions such as solution, concentration and temperature.



Equivalents & Conversions

Table 12

Metric System Length

UNIT	METRIC EQUIVALENT	U.S. EQUIVALENT
millimeter (mm)	= 0.001 meter	= 0.03937 inch
centimeter (cm)	= 0.01 meter	= 0.3937 inch
decimeter (dm)	= 0.1 meter	= 3.937 inches
METER (m)	= 1.0 meter	= 39.37 inches
dekameter (dkm)	= 10.0 meter	= 10.93 yards
hectometer (hm)	= 100.0 meters	= 328.08 feet
kilometer (km)	= 1000.0 meters	= 0.6214 mile

Metric system/capacity

Unit	Metric Equivalent	U.S. Equivalent
milliliter (ml)	= 0.001 liter	= 0.034 fluid ounce
centiliter (cl)	= 0.01 liter	= 0.338 fluid ounce
deciliter (dl)	= 0.1 liter	= 3.38 fluid ounces
LITER (l)	= 1.0 liter	= 1.05 liquid quarts
dekaliter (dkl)	= 10.0 liters	= 0.284 bushel
hectoliter (hl)	= 100.0 liters	= 2.837 bushels
kiloliter (kl)	= 1000.0 liters	= 264.18 gallons

Metric system/weight or mass

UNIT	METRIC EQUIVALENT	U.S. EQUIVALENT
milligram (mg)	= 0.001 gram	= 0.0154 grain
centigram (cg)	= 0.01 gram	= 0.1543 grain
decigram (dg)	= 0.1 gram	= 1.543 grains
GRAM (g)	= 1.0 gram	= 15.43 grains
dekagram (dkg)	= 10.0 grams	= 0.3527 ounce avoirdupois
hectogram (hg)	= 100.0 grams	= 3.527 ounce avoirdupois
kilogram (kg)	= 1000.0 grams	= 2.2 pounds avoirdupois

Metric system/area

UNIT	METRIC EQUIVALENT	U.S. EQUIVALENT
squared millimeter (mm ²)	= 0.000001 centare	= 0.00155 square inch
squared centimeter (cm ²)	= 0.0001 centare	= 0.155 square inch
square decimeter (dm ²)	= 0.01 centare	= 15.5 square inch
CENTARE also (ca)	= 1.0 centare	= 10.76 square feet
square meter (m ²)		
are also (a)	= 100.0 centares	= 0.0247 acre
square dekameter (dkm ²)		
hectare also (ha)	= 10,000.0 centares	= 2.47 acre
square hectometer (hm ²)		
square kilometer (km ²)	= 1,000,000.0 centares	= 0.386 square mile

Metric system/volume

UNIT	METRIC EQUIVALENT	U.S. EQUIVALENT
cubic millimeter (mm ³)	= 0.001 cubic centimeter	= 0.016 minim
cubic centimeter (cc, cm ³)	= 0.001 cubic decimeter	= 0.061 cubic inch
cubic decimeter (dm ³)	= 0.001 cubic meter	= 61.023 cubic inches
STERE also (s)	= 1.0 cubic meter	= 1.308 cubic yards
cubic meter (m ³)		
cubic dekameter (dkm ³)	= 1000.0 cubic meters	= 1307.943 cubic yards
cubic hectometer (hm ³)	= 1000,000.0 cubic meters	= 1,307,942.8 cubic yards
cubic kilometer (km ³)	= 1,000,000,000.0 cubic meters	= 0.25 cubic mile

Pressure

UNIT	ATM	KG/CM ²	LB/IN ²	BAR	MM Hg (0°C)	IN Hg (32°F)	FT H ₂ O (60°F)
1 Atmosphere	1*	1.033228	14.6959	1.013250	760*	29.921	33.934
1kg./cm ²	0.967841	1*	14.2233	0.980665*	735.559	28.959	32.843
10lb./in ²	0.68046	0.70307	10*	0.689476	517.149	20.360	23.091
1 bar	0.986923	1.019716	14.5038	1*	750.062	29.530	33.490
1 meter Hg(0°C)	1.31579	1.35951	19.3368	1.333224	1000*	39.370	44.65
10 in. Hg(32°F)	0.33421	0.34532	4.9115	0.33864	254*	10*	11.341
100ft. H ₂ O(60°F)	2.9469	3.0448	43.308	2.9859	2239.6	88.175	100*

1 inch of Hg (mercury) = 13.6 inch H₂O 1 PSI = 2.31 inches of H₂O

Conversion Table

1 Btu = 251.996 international calories

Multiply no. of...	By...	To Obtain...
BRITISH THERMAL UNITS	778.3	Foot-pound
	3.929 x 10 ⁻⁴	Horsepower-hours
	2.930 x 10 ⁻⁴	Kilowatt-hours
	.2930	Watts-hours
FOOT-POUNDS	1.285 x 10 ⁻³	British thermal units
	5.05 x 10 ⁻⁷	Horsepower-hours
	3.766 x 10 ⁻⁷	Kilowatt-hours
	3.766 x 10 ⁻⁴	Watt-hours
HORSEPOWER-HOURS	2545	British thermal units
	1.98 x 10 ⁴	Foot-pound
	.7457	Kilowatt-hours
	745.7	Watt-hours
KILOWATT-HOURS	3413	British thermal units
	2.655 x 10 ⁶	Foot-pounds
	1.341	Horsepower-hours
	1000	Watt-hours
WATT-HOURS	3.413	British thermal units
	2655	Foot-pounds
	1.341 x 10 ⁻³	Horsepower-hours
	.001	Kilowatt-hours

Conversion Factors

LENGTH	WEIGHT
1 in. = 2.54 cm	1 kg. = 2.205 lb.
1 ft. = .3048 m	
1 yd. = .9144 m	
1 m = 39.37 in	
AREA	VOLUME
1 in ² = 6.452 cm ²	1 in ³ = 16.39 cm ³
1 ft ² = .0929 m ²	1 ft ³ = .02832 m ³
	1 ft ³ = 62.43 lb. water
	1 ft ³ = 7.5 gal water
	1 ft ³ = 28.32 liters
	1 U.S. gal = .1337 ft ³
	1 U.S. gal = 231 ft ³
HORSEPOWER	1 U.S. gal = 8.345 lb water
1 hp. = .746 kW	1 U.S. gal = 3.785 liters
1 boiler hp. = 9.8 kW	

Natural gas equivalent

One therm. = 1,000,000 BTU
 One ft³. of gas = 1040 BTU (range 1020-1055)
 One therm (rounding off) = 1000 ft³. gas
 One MCF = 1,040,000 BTU

Multiply no. of...	By...	To obtain...
bar	.987	atmosphere
bar	100,000	pascal
barrel, 42 US gal.	.159	meters ³
calorie	4.184	Joule
Joule	.00095	BTU
Kilojoule	3.600	kilowatt-hour
Kilograms/cm ²	14.2	pounds/in ²



Conversion Tables

AMPERAGE CONVERSION TABLE

Table 13

Watts	Volts Single Phase			Volts 3 Phase Balanced Load		Watts
	120	240	480	240	480	
100	.83	.42	.21	.24	.13	100
150	1.25	.63	.31	.36	.18	150
200	1.67	.83	.42	.49	.25	200
250	2.08	1.04	.52	.61	.30	250
300	2.50	1.25	.63	.73	.37	300
350	2.92	1.46	.73	.85	.43	350
400	3.33	1.67	.84	.97	.49	400
450	3.75	1.88	.93	1.10	.55	450
500	4.17	2.08	1.04	1.20	.60	500
600	5.00	2.50	1.25	1.45	.73	600
700	5.83	2.92	1.46	1.70	.85	700
750	6.25	3.13	1.56	1.81	.91	750
800	6.67	3.33	1.67	1.67	.97	800
900	7.50	3.75	1.87	2.17	1.09	900
1000	8.33	4.17	2.10	2.41	1.21	1000
1100	9.17	4.58	2.30	2.65	1.33	1100
1200	10.00	5.00	2.51	2.90	1.45	1200
1250	10.40	5.21	2.61	3.10	1.55	1250
1300	10.80	5.42	2.71	3.13	1.57	1300
1400	11.70	5.83	2.91	3.38	1.69	1400
1500	12.50	6.25	3.12	3.62	1.82	1500
1600	13.30	6.67	3.34	3.86	1.93	1600
1700	14.20	7.08	3.54	4.10	2.05	1700
1750	14.60	7.29	3.65	4.22	2.10	1750
1800	15.00	7.50	3.75	4.34	2.17	1800
1900	15.80	7.92	3.96	4.58	2.29	1900
2000	16.70	8.33	4.17	4.82	2.41	2000
2200	18.30	9.17	4.59	5.30	2.65	2200
2500	20.80	10.40	5.21	6.10	3.05	2500
2750	23.00	11.50	5.73	6.63	3.32	2750
3000	25.00	12.50	6.25	7.23	3.62	3000
3500	29.20	14.60	7.30	8.45	4.23	3500
4000	33.30	16.70	8.33	9.64	4.82	4000
4500	37.50	18.80	9.38	10.84	5.42	4500
5000	41.70	20.80	10.42	12.10	6.10	5000
6000	50.00	25.00	12.50	14.50	7.25	6000
7000	58.30	29.20	14.59	16.90	8.50	7000
8000	66.70	33.30	16.67	19.30	9.65	8000
9000	75.00	37.50	18.75	21.70	10.85	9000
10000	83.30	41.70	20.85	24.10	12.10	10000

Important Metric Prefixes

Prefix	Abbre-via-tion	Meaning	Typical Examples
peta	P	$\times 10^{15}$	1 petayear = 10^1 years
tera	T	$\times 10^{12}$	1 terayear = 10^{12} years
giga	G	$\times 10^9$	1 gigahertz (radar frequency) = 10^9 Hz
mega	M	$\times 10^6$	1 megaton (equivalent TNT strength of nuclear weapon) = 10^6 tons
kilo	k	$\times 10^3$	1 kilogram = 1000 g
deci	d	$\times 10^{-1}$	1 decimeter = 0.1 m
centi	c	$\times 10^{-2}$	1 centimeter = 0.01 m
milli	m	$\times 10^{-3}$	1 milliampere = 0.001 A
micro	μ	$\times 10^{-6}$	microvolt = 10^{-6} V
nano	n	$\times 10^{-9}$	1 nanosecond = 10^{-9} second
pico	p	$\times 10^{-12}$	1 picofarad = 10^{-12} F
femto	f	$\times 10^{-15}$	1 femtometer (approximate size of a proton) = 10^{-15} m

HARDNESS CONVERSION TABLE

Table 14

Brinell		Rockwell (Approximate Value)				Tensile Strength 1000 Shore lb./sq in.	
Diameter 3000 Kg. Load 10 mm. Ball	Hard- ness No.	C	B	A	15-N		
2.25	745	65.3	—	84.1	92.3	91	—
2.30	712	—	—	—	—	—	—
2.35	682	61.7	—	82.2	91.0	84	—
2.40	653	60.0	—	81.2	90.2	81	—
2.45	627	58.7	—	80.5	89.6	79	—
2.50	601	57.3	—	79.8	89.0	77	—
2.55	578	56.0	—	79.1	88.4	75	—
2.60	555	54.7	—	78.4	87.8	73	298
2.65	534	53.5	—	77.8	87.2	71	288
2.70	514	52.1	—	76.9	86.5	70	274
2.75	495	51.0	—	76.3	85.9	68	264
2.80	477	49.6	—	75.0	85.3	66	252
2.85	461	48.5	—	74.9	84.7	65	242
2.90	444	47.1	—	74.2	84.0	63	230
2.95	429	45.7	—	73.4	83.4	61	219
3.00	415	44.5	—	72.8	82.8	59	212
3.05	401	43.1	—	72.0	82.0	58	202
3.10	388	41.8	—	71.4	81.4	56	193
3.15	375	40.4	—	70.6	80.6	54	184
3.20	363	39.1	—	70.0	80.0	52	177
3.25	352	37.9	(110.0)	69.3	79.3	51	170
3.30	341	36.6	(109.0)	68.7	78.6	50	163
3.35	331	35.5	(108.5)	68.1	78.0	48	158
3.40	321	34.3	(108.0)	67.5	77.3	47	152
3.45	311	33.1	(107.5)	66.9	76.7	46	147
3.50	302	32.1	(107.0)	66.3	76.1	45	143
3.55	293	30.9	(106.0)	65.7	75.5	43	139
3.60	285	29.9	(105.5)	65.3	75.0	42	135
3.65	277	28.8	(104.5)	64.6	74.4	41	131
3.70	269	27.6	(104.0)	64.1	73.7	40	128
3.75	262	26.6	(103.0)	63.6	73.1	39	125
3.80	255	25.4	(102.0)	63.0	72.5	38	121
3.85	248	24.2	(101.0)	62.5	71.7	37	118
3.90	241	22.8	100.0	61.8	70.9	36	114
3.95	235	21.7	99.0	61.4	70.3	35	111
4.00	229	20.5	98.2	60.8	69.7	34	109
4.05	223	(18.8)	97.3	—	—	—	104
4.10	217	(17.5)	96.4	—	—	33	103
4.15	212	(16.0)	95.5	—	—	—	100
4.20	207	(15.2)	94.6	—	—	32	99
4.25	201	(13.8)	93.8	—	—	31	97
4.30	197	(12.7)	92.8	—	—	30	94
4.35	192	(11.5)	91.9	—	—	29	92
4.40	187	(10.0)	90.7	—	—	—	90
4.45	183	(9.0)	90.0	—	—	28	89
4.50	179	(8.0)	89.0	—	—	27	88
4.55	174	(6.4)	87.8	—	—	—	86
4.60	170	(5.4)	86.8	—	—	26	84
4.65	167	(4.4)	86.0	—	—	—	83
4.70	163	(3.3)	85.0	—	—	25	82
4.80	156	(0.9)	82.9	—	—	—	80
4.90	149	—	80.8	—	—	23	—
5.00	143	—	78.7	—	—	22	—
5.10	137	—	76.4	—	—	21	—
5.20	131	—	74.0	—	—	—	—
5.30	126	—	72.0	—	—	20	—
5.40	121	—	69.8	—	—	19	—
5.50	116	—	67.6	—	—	18	—
5.60	111	—	65.7	—	—	15	—

Hardness values are from SAE-ASM-ASTM Committees on Hardness conversions as printed in ASTM E 140, Table 14. Tensile strength values are from Federal Test Methods Standard No. 151-A - method 241.2 dated January 10, 1961.



Table 15 TABLE OF EQUIVALENT TEMPERATURES

°C	°F	°C	°F	°C	°F	°C	°F	°C	°F	°C	°F	°C	°F	°C	°F
-50	-58	75	167	200	392	325	617	450	842	575	1067	700	1292	825	1517
-45	-49	80	176	205	401	330	626	455	851	580	1076	705	1301	830	1526
-40	-40	85	185	210	410	335	635	460	860	585	1085	710	1310	835	1535
-35	-31	90	194	215	419	340	644	465	869	590	1094	715	1319	840	1544
-30	-22	95	203	220	428	345	653	470	878	595	1103	720	1328	845	1553
-25	-13	100	212	225	437	350	662	475	887	600	1112	725	1337	850	1562
-20	-4	105	221	230	446	355	671	480	896	605	1121	730	1346	855	1571
-15	-5	110	230	235	455	360	680	485	905	610	1130	735	1355	860	1580
-10	14	115	239	240	464	365	689	490	914	615	1139	740	1364	865	1589
-5	23	120	248	245	473	370	698	495	923	620	1148	745	1373	870	1598
0	32	125	257	250	482	375	707	500	932	625	1157	750	1382	875	1607
5	41	130	266	255	491	380	716	505	941	630	1166	755	1391	880	1616
10	50	135	275	260	500	385	725	510	950	635	1175	760	1400	885	1625
15	59	140	284	265	509	390	734	515	959	640	1184	765	1409	890	1634
20	68	145	293	270	518	395	743	520	968	645	1193	770	1418	895	1643
25	77	150	302	275	527	400	752	525	977	650	1202	775	1427	900	1652
30	86	155	311	280	536	405	761	530	986	655	1211	780	1436	905	1661
35	95	160	320	285	545	410	770	535	995	660	1220	785	1445	910	1670
40	104	165	329	290	554	415	779	540	1004	665	1229	790	1454	915	1679
45	113	170	338	295	563	420	788	545	1013	670	1238	795	1463	920	1688
50	112	175	347	300	572	425	797	550	1022	675	1247	800	1472	925	1697
55	131	180	356	305	581	430	806	555	1031	680	1256	805	1481	930	1706
60	140	185	365	310	590	435	815	560	1040	685	1265	810	1490	935	1715
65	149	190	374	315	599	440	824	565	1049	690	1274	815	1499	940	1724

Values for interpolation in above

1°C = 1.8°F	4°C = 7.2°F	7°C = 12.6°F	1°F = 0.55°C	4°F = 2.22°C	7°F = 3.88°C
2°C = 3.6°F	5°C = 9.0°F	8°C = 14.4°F	2°F = 1.11°C	5°F = 2.77°C	8°F = 4.44°C
3°C = 5.4°F	6°C = 10.8°F	9°C = 16.2°F	3°F = 1.66°C	6°F = 3.33°C	9°F = 5.00°C

All decimals are exact

Table 16 PERCENT OF RATED WATTAGE FOR VARIOUS APPLIED VOLTAGES

Applied Voltage	Rated Voltage													
	110	115	120	208	220	230	240	277	380	415	440	460	480	550
110	100%	91%	84%	28%	25%	23%	21%	16%	8.4%	7%	6.2%	5.7%	5.2%	4%
115	109%	100%	92%	31%	27%	25%	23%	17%	9.0%	7.6%	6.7%	6.2%	5.7%	4.3%
120	119%	109%	100%	33%	30%	27%	25%	19%	10%	8.4%	7.4%	6.8%	6.3%	4.8%
208			300%	100%	89%	82%	75%	56%	30%	25%	22%	20%	19%	14%
220				112%	100%	91%	84%	63%	34%	28%	25%	23%	21%	16%
230				122%	109%	100%	92%	69%	37%	31%	27%	25%	23%	17%
240				133%	119%	109%	100%	75%	40%	33%	30%	27%	25%	19%
277							133%	100%	53%	45%	40%	36%	33%	25%
380								188%	100%	84%	74%	68%	63%	47%
415									119%	100%	89%	81%	75%	57%
440										112%	100%	91%	84%	64%
460										123%	109%	100%	92%	70%
480											119%	109%	100%	76%
550											156%	143%	131%	100%

For voltages not shown above, you can calculate the actual wattage with this formula:

$$\text{Actual wattage} = \text{Rated wattage} \cdot \frac{\text{Applied voltage}^2}{\text{Rated voltage}^2}$$

- °K = °C + 273
- °R = °F + 460
- °F = 9/5 °C + 32
- °C = (°F - 32) X 5/9
- °C = Degrees Celsius
- °F = Degrees Fahrenheit
- °K = Degrees Kelvin
- °R = Degrees Rankine



DECIMAL & MILLIMETER EQUIVALENTS

	DECIMALS	MILLIMETERS
$\frac{1}{64}$	0.015625	— 0.397
$\frac{1}{32}$.03125	— 0.794
$\frac{3}{64}$.046875	— 1.191
$\frac{1}{16}$.0625	— 1.588
$\frac{5}{64}$.078125	— 1.984
$\frac{3}{32}$.09375	— 2.381
$\frac{7}{64}$.109375	— 2.778
$\frac{1}{8}$.1250	— 3.175
$\frac{9}{64}$.140625	— 3.572
$\frac{5}{32}$.15625	— 3.969
$\frac{11}{64}$.171875	— 4.366
$\frac{3}{16}$.1875	— 4.763
$\frac{13}{64}$.203125	— 5.159
$\frac{7}{32}$.21875	— 5.556
$\frac{15}{64}$.234375	— 5.953
$\frac{1}{4}$.2500	— 6.350
$\frac{17}{64}$.265625	— 6.747
$\frac{9}{32}$.28125	— 7.144
$\frac{19}{64}$.296875	— 7.541
$\frac{5}{16}$.3125	— 7.938
$\frac{21}{64}$.328125	— 8.334
$\frac{11}{32}$.34375	— 8.731
$\frac{23}{64}$.359375	— 9.128
$\frac{3}{8}$.3750	— 9.525
$\frac{25}{64}$.390625	— 9.922
$\frac{13}{32}$.40625	— 10.319
$\frac{27}{64}$.421875	— 10.716
$\frac{7}{16}$.4375	— 11.113
$\frac{29}{64}$.453125	— 11.509
$\frac{15}{32}$.46875	— 11.906
$\frac{31}{64}$.484375	— 12.303
$\frac{1}{2}$.500	— 12.700

1mm = .03937"

	DECIMALS	MILLIMETERS
$\frac{33}{64}$	0.515625	— 13.097
$\frac{17}{32}$.53125	— 13.494
$\frac{35}{64}$.546875	— 13.891
$\frac{9}{16}$.5625	— 14.288
$\frac{37}{64}$.578125	— 14.684
$\frac{19}{32}$.59375	— 15.081
$\frac{39}{64}$.609375	— 15.478
$\frac{5}{8}$.6250	— 15.875
$\frac{41}{64}$.640625	— 16.272
$\frac{21}{32}$.65625	— 16.669
$\frac{43}{64}$.671875	— 17.066
$\frac{11}{16}$.6875	— 17.463
$\frac{45}{64}$.703125	— 17.859
$\frac{23}{32}$.71875	— 18.256
$\frac{47}{64}$.734375	— 18.653
$\frac{3}{4}$.7500	— 19.050
$\frac{49}{64}$.765625	— 19.447
$\frac{25}{32}$.78125	— 19.844
$\frac{51}{64}$.796875	— 20.241
$\frac{13}{16}$.8125	— 20.638
$\frac{53}{64}$.828125	— 21.034
$\frac{27}{32}$.84375	— 21.431
$\frac{55}{64}$.859375	— 21.828
$\frac{7}{8}$.8750	— 22.225
$\frac{57}{64}$.890625	— 22.622
$\frac{29}{32}$.90625	— 23.019
$\frac{59}{64}$.921875	— 23.416
$\frac{15}{16}$.9375	— 23.813
$\frac{61}{64}$.953125	— 24.209
$\frac{31}{32}$.96875	— 24.606
$\frac{63}{64}$.984375	— 25.003
1	1.000	— 25.400

.001" = .0254mm

	MM	INCHES		MM	INCHES
.1	.0039		46	—	1.8110
.2	.0079		47	—	1.8504
.3	.0118		48	—	1.8898
.4	.0158		49	—	1.9291
.5	.0197		50	—	1.9685
.6	.0236		51	—	2.0079
.7	.0276		52	—	2.0472
.8	.0315		53	—	2.0866
.9	.0354		54	—	2.1260
1	.0394		55	—	2.1654
2	.0787		56	—	2.2047
3	.1181		57	—	2.2441
4	.1575		58	—	2.2835
5	.1969		59	—	2.3228
6	.2362		60	—	2.3622
7	.2756		61	—	2.4016
8	.3150		62	—	2.4409
9	.3543		63	—	2.4803
10	.3937		64	—	2.5197
11	.4331		65	—	2.5591
12	.4724		66	—	2.5984
13	.5118		67	—	2.6378
14	.5512		68	—	2.6772
15	.5906		69	—	2.7165
16	.6299		70	—	2.7559
17	.6693		71	—	2.7953
18	.7087		72	—	2.8346
19	.7480		73	—	2.8740
20	.7874		74	—	2.9134
21	.8268		75	—	2.9528
22	.8661		76	—	2.9921
23	.9055		77	—	3.0315
24	.9449		78	—	3.0709
25	.9843		79	—	3.1102
26	1.0236		80	—	3.1496
27	1.0630		81	—	3.1890
28	1.1024		82	—	3.2283
29	1.1417		83	—	3.2677
30	1.1811		84	—	3.3071
31	1.2205		85	—	3.3465
32	1.2598		86	—	3.3858
33	1.2992		87	—	3.4252
34	1.3386		88	—	3.4646
35	1.3780		89	—	3.5039
36	1.4173		90	—	3.5433
37	1.4567		91	—	3.5827
38	1.4961		92	—	3.6220
39	1.5354		93	—	3.6614
40	1.5748		94	—	3.7008
41	1.6142		95	—	3.7402
42	1.6535		96	—	3.7795
43	1.6929		97	—	3.8189
44	1.7323		98	—	3.8583
45	1.7717		99	—	3.8976
			100	—	3.9370



Table 17 WIRE CURRENT CARRYING CAPACITY TABLE

40°C Ambient Temperature

WIRE GA.	150°C TINNED COPPER	200°C TINNED COPPER NPC 2%-10%	250°C NPC 2%-10%	250°C "A" NICKEL	250°C NPI	450°C NPC 27%	450°C "A" NICKEL
24	6.6 amps	7.2 amps	8 amps	4 amps	3.3 amps	9 amps	4.3 amps
22	9	9.6	10.8	5	4.4	12	5.6
20	13	14	15	7	6	18	8
18	17	18	20	9.4	8	23	11
16	22	24	26	12	11	30	14
14	34	36	39	18	16	45	21
12	43	45	54	25	22	56	26
10	55	60	73	34	30	75	35
8	76	83	93	43	39	104	49
6	96	110	117	55	49	138	65
4	120	125	148	69	62	162	76
3	143	152	166	78	69	182	85
2	160	171	191	90	80	210	99
1	186	197	215	101	90	236	110
1/0	215	229	244	114	102	268	126
2/0	251	260	273	128	114	300	141
3/0	288	297	308	144	129	338	159
4/0	332	346	361	169	151	397	186
250	365	385	398	187	167	***	***
300	414	436	452	212	190	***	***
350	461	486	503	236	211	***	***
400	495	522	540	254	226	***	***
500	563	593	613	288	257	***	***

Table 18 WIRE TEMPERATURE RATING

To calculate temperature correction factors for ambient temperatures other than 40°C (104°F) multiply the current rating shown above by the factors shown in this table.

Ambient Temp.°C	200°C	250°C	450°C	Ambient Temp.°F	Ambient Temp.°C	200°C	250°C	450°C	Ambient Temp.°F
41-50	0.97	0.98	.099	106-122	181-200	***	0.49	0.78	357-392
51-60	0.94	0.95	0.99	124-140	201-225	***	0.35	0.74	393-437
61-70	0.90	0.93	0.96	142-158	226-250	***	***	0.69	439-482
71-80	0.87	0.90	0.95	160-176	251-275	***	***	0.65	483-527
81-90	0.83	0.87	0.93	177-194	276-300	***	***	0.60	528-572
91-100	0.72	0.85	0.92	195-212	301-325	***	***	0.55	573-617
101-120	0.71	0.79	0.89	213-248	326-350	***	***	0.49	618-662
121-140	0.61	0.71	0.86	249-284	351-375	***	***	0.42	663-707
141-160	0.50	0.65	0.84	285-320	376-400	***	***	0.34	708-752
161-180	0.35	0.58	0.81	321-356					



Trigonometric Solutions

PYTHAGOREAN THEOREM

$$a^2 + b^2 = c^2$$

EXAMPLE:

$$a = 3; b = 4; c = 5$$

$$3^2 + 4^2 = 5^2$$

$$9 + 16 = 25$$

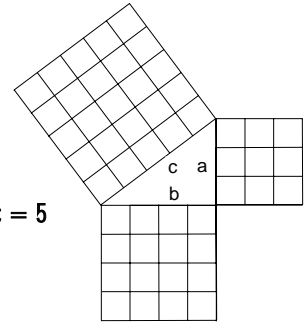

TRIGONOMETRIC FUNCTIONS

ANGLE A		DEFINITIONS	ANGLE B	
	$\sin A = \frac{a}{c} = \frac{1}{\text{cosec } A} = \frac{\cos A}{\cot A} = \cos A \cdot \tan A$	$\sin = \frac{\text{opposite side}}{\text{hypotenuse}}$		$\sin B = \frac{b}{c}$
	$\cos A = \frac{b}{c} = \frac{1}{\text{sec } A} = \frac{\sin A}{\tan A} = \sin A \cdot \cot A$	$\cos = \frac{\text{adjacent side}}{\text{hypotenuse}}$		$\cos B = \frac{a}{c}$
	$\tan A = \frac{a}{b} = \frac{1}{\cot A} = \frac{\sin A}{\cos A} = \sin A \cdot \sec A$	$\tan = \frac{\text{opposite side}}{\text{adjacent side}}$		$\tan B = \frac{b}{a}$
	$\cot A = \frac{b}{a} = \frac{1}{\tan A} = \frac{\cos A}{\sin A} = \cos A \cdot \text{cosec } A$	$\cot = \frac{\text{adjacent side}}{\text{opposite side}}$		$\cot B = \frac{a}{b}$
	$\sec A = \frac{c}{b} = \frac{1}{\cos A} = \frac{\tan A}{\sin A} = \tan A \cdot \text{cosec } A$	$\sec = \frac{\text{hypotenuse}}{\text{adjacent side}}$		$\sec B = \frac{c}{a}$
	$\text{cosec } A = \frac{c}{a} = \frac{1}{\sin A} = \frac{\cot A}{\cos A} = \cot A \cdot \sec A$	$\text{cosec} = \frac{\text{hypotenuse}}{\text{opposite side}}$		$\text{cosec } B = \frac{c}{b}$

TRIGONOMETRIC SOLUTIONS FOR RIGHT ANGLE TRIANGLES

LINE	GIVEN				SOUGHT					AREA	
	Sides			Angles		SIDES			ANGLES		
	a	b	c	A	B	a	b	c	A		B
1	a	-	c	-	-	-	$\sqrt{c^2 - a^2}$	-	$\frac{a}{c} = \sin A$	$\frac{a}{c} = \cos B$	$\frac{a}{2} \sqrt{c^2 - a^2}$
2	-	b	c	-	-	$\sqrt{c^2 - b^2}$	-	-	$\frac{b}{c} = \cos A$	$\frac{b}{c} = \sin B$	$\frac{b}{2} \sqrt{c^2 - b^2}$
3	a	b	-	-	-	-	$\sqrt{a^2 + b^2}$	-	$\frac{a}{b} = \tan A$	$\frac{b}{a} = \tan B$	$\frac{ab}{2}$
4	-	-	c	A	-	$c \sin A$	$c \cos A$	-	-	$90^\circ - A$	$\frac{c^2 \sin A \cos A}{2}$
5	-	-	c	-	B	$c \cos B$	$c \sin B$	-	$90^\circ - B$	-	$\frac{c^2 \sin B \cos B}{2}$
6	a	-	-	A	-	-	$a \cot A$	$\frac{a}{\sin A}$	-	$90^\circ - A$	$\frac{a^2 \cot A}{2}$
7	a	-	-	-	B	-	$a \tan B$	$\frac{a}{\cos B}$	$90^\circ - B$	-	$\frac{a^2 \tan B}{2}$
8	-	b	-	A	-	$b \tan A$	-	$\frac{b}{\cos A}$	-	$90^\circ - A$	$\frac{b^2 \tan A}{2}$
9	-	b	-	-	B	$b \cot B$	-	$\frac{b}{\sin B}$	$90^\circ - B$	-	$\frac{b^2 \cot B}{2}$



Wiring Configurations & Diagrams

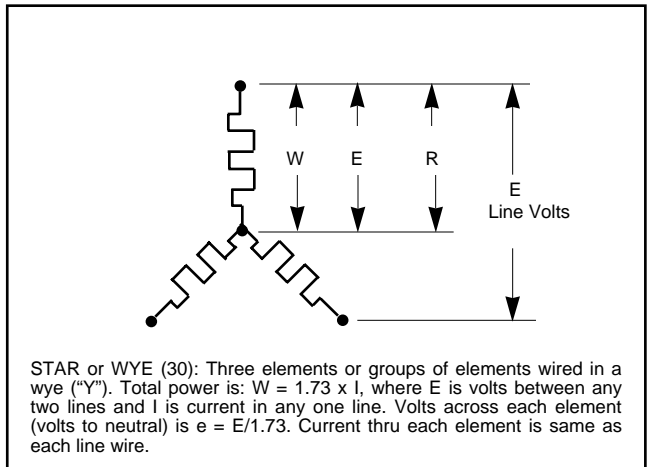
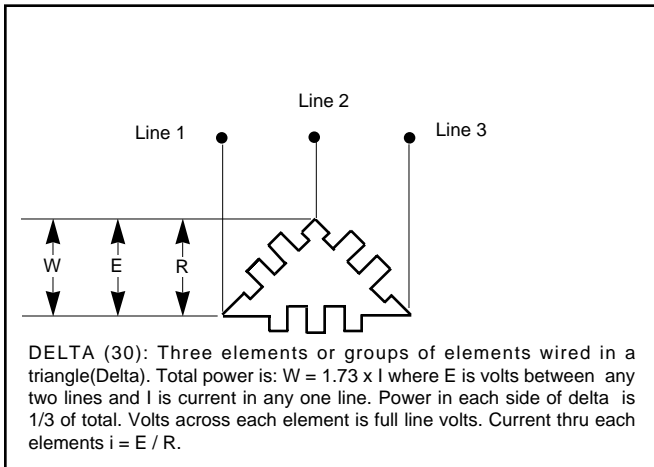
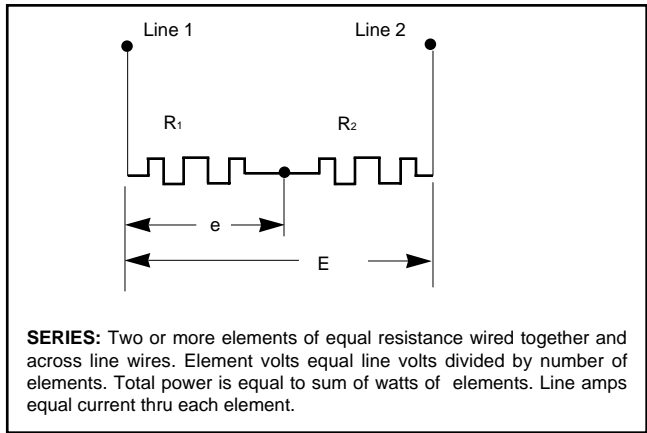
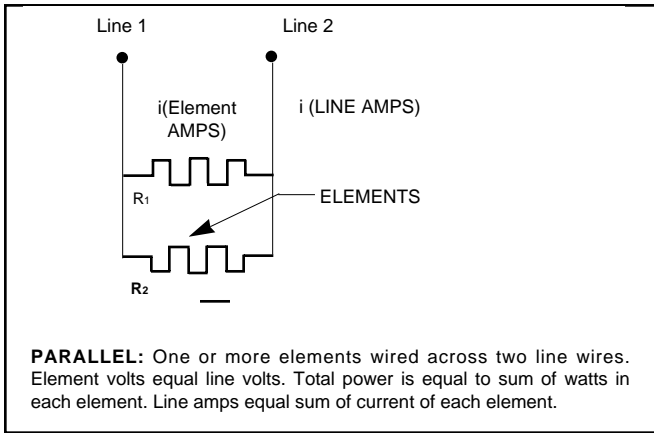

WIRING CONFIGURATIONS	HEATER ELEMENT VALUES (formulas and symbols)			
	VOLTS (e)	AMPS (i)	WATTS (W)	RESISTANCE (R)
Parallel	line volts (E)	$\frac{\text{line volts (E)}}{\text{element Ohms (Rn)}}$	$E \times i$	E / i
Series	$\frac{\text{line volts (E)}}{\text{\# of elements}}$	line Amps (I)	$e \times i$	e / i
Delta	line volts (E)	$\frac{\text{line Amps (I)}}{1.73}$	$e \times i$	E / i and $E/1.73 \times I$
Star (Wye)	$E / 1.73$	line Amps (I)	$e \times i$ and $(E \times I) / 1.73$	$e \times i$ and $E/1.73 \times I$

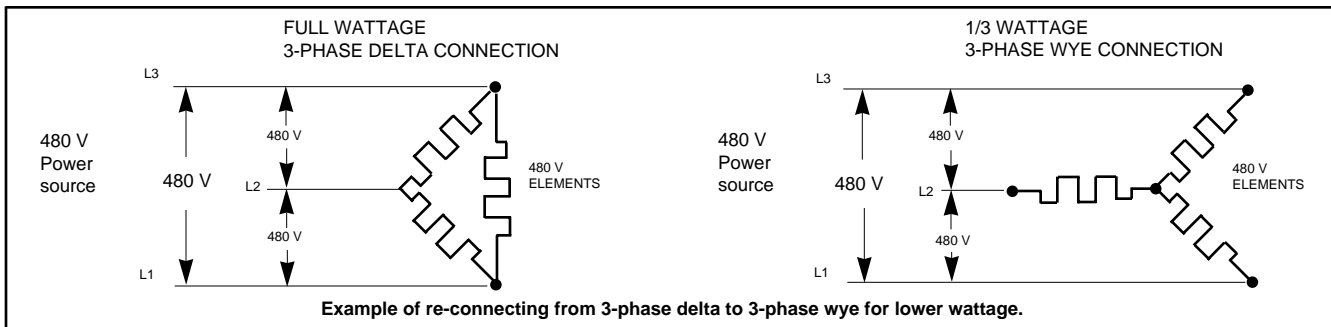

These wiring configurations are provided to assist in the wiring of the heating elements in parallel, series & 3-phase (Delta or Wye).

SUGGESTED WIRING PRACTICES FOR ELECTRIC HEATERS

When selecting wiring for electric heater circuits, it should be recognized that wiring may be operating at temperatures above room ambient. These temperatures may be the result of conducted heat from heater terminals, radiation from heater surfaces, or due to high ambient temperatures. In high temperature areas, wiring must employ high-temperature insulation and/or nickel plated copper or high temperature nickel alloy conductors. Outside the heated zone, conventional wiring methods and materials are generally used. The recommendations which follow are only suggestions for minimum good wiring practice and are not to conflict with the National Electric Code or local codes.

SELECTING TYPE OF WIRE

The table below lists some of the more common code wire constructions according to their temperature capabilities. A more complete listing may be found in current issues of the National Electric Code on good wiring practice. Selection of type of wire will be dependent upon operating temperature and electric service voltage to be employed.

EXPLOSION-PROOF WIRING

Where hazardous conditions exist, approved explosion-proof terminal and junction boxes should be used. M1 cable or rigid conduit is mandatory and thread joints should be wrench tight but need not be sealed (refer to NEC).

Maximum Wire Operating Temperature		Line Voltages Up to 300 V Wire Type	Line Voltages Up to 600 V Wire Type	Construction
CENTIGRADE C	FAHRENHEIT F			
60	140	Use 600 V wire	T TW	Thermoplastic over copper Moisture resistant thermoplastic over copper
75	167		RHW THWN	Moisture and heat-resist rubber Moisture and heat-resist thermoplastic over copper
90	194	Use 600 V wire	RHH THHN	Heat-resistant rubber over copper Heat-resistant thermoplastic over copper
200	392		FEP SRG	Teflon over copper Silicone rubber & glass braid over copper
High Temperature Applications				
250	482	Use 600 V wire	TGT TGS	Teflon tape with teflon impregnated glass braid over nickel plated copper Teflon tape with silicone impregnated impregnated glass braid over nickel plated copper
450	842		MGS MGT	Mica tape with silicone impregnated glass braid over nickel plated copper Mica tape with teflon impregnated glass braid over nickel plated copper
594	1100	Bare manganese nickel wire or bus bar with ceramic tube or bead insulation.		

THERMOCOUPLE WIRE SELECTION FOR ELECTRIC HEATERS

THERMOCOUPLE WIRE COLOR CODE

Thermocouple wires are color coded (See table below) to aid in their polarity identification and to avoid cross wiring. "J" type thermocouples have a useful temperature range of 32 to 1382°F. "K" type thermocouple temperature range is from -326 to 2282 °F.

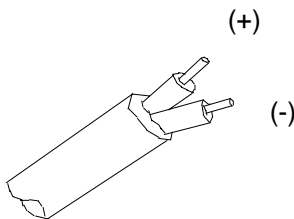

All negative (-) conductors have red color coded insulation.

THERMOCOUPLES

Positive (+) Conductor	Insulation Color Coded	Alloys
J	White	Iron Constantan
K	Yellow	Chromel/Alumel
T	Blue	Copper/Constantan
E	Purple	Chromel/Constantan
R	Black	Platinum/Platinum (with 13% Rodium)
S	Black	Platinum/Platinum (with 10% Rodium)
N	Orange	Nicrosil/Nisil



Temperature & Power Controls

MECHANICAL RELAY CONTROL OUTPUT WIRING(SINGLE PHASE)

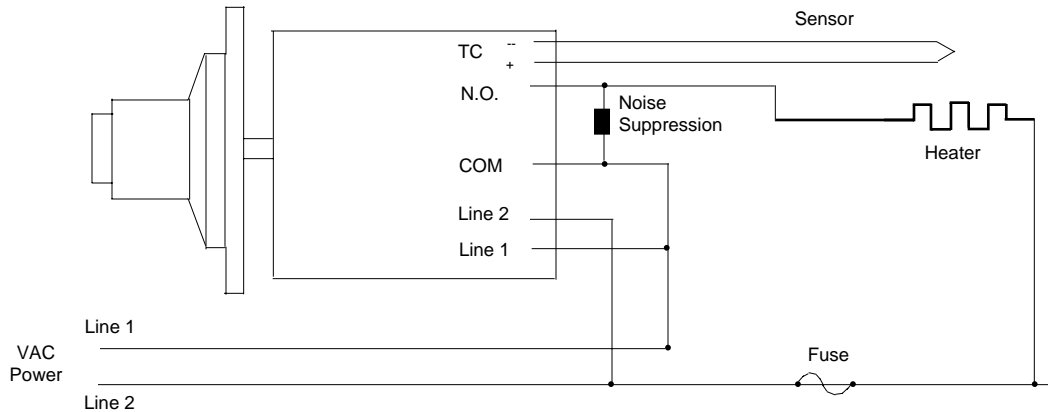

Operation Of The Mechanical Relay Control Output Wiring

The normally open (N.O.) and common (COM) contacts of the mechanical relay operates as switch contacts. When a temperature controller calls for heat, the contacts will close and there will be continuity.

Note:

The specified current rating for mechanical relays is at 120/240VAC and can be rated differently at other voltages.

SOLID STATE SWITCH CONTROL OUTPUT WIRING (SINGLE PHASE)

Load power thru an external contractor

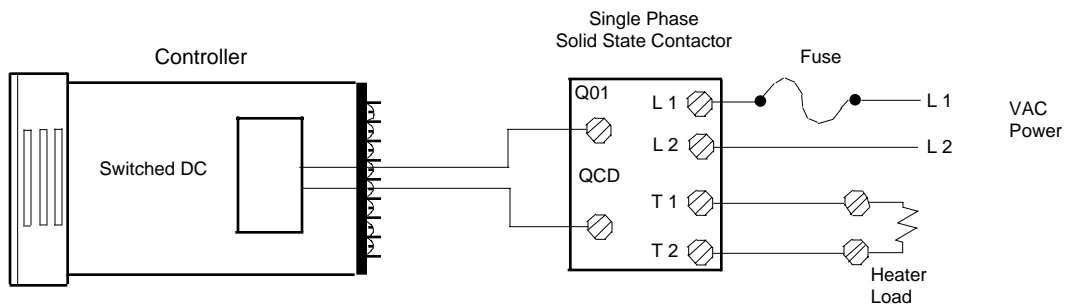

Operation Of The Solid State Switch Control Output Wiring

When a heating control calls for temperature rise, the switched DC output (a transistor) turns ON, developing voltage across the output terminal, which turns ON the solid state contactor and then the load.

Temperature & Power Controls cont.

3-PHASE "DELTA" & "STAR" (WYE) OUTPUT WIRING

Load power thru external contractor

Operation of 3-Phase Control Output Wiring

The controller and 3-phase contactor should be wired for the desired delta or wye configurations. The controller can normally operate at 120/240 vac single-phase with an output signal of 4-20mA. When the heater control calls for temperature rise, the output signal to the controller will send a 4-20mA output signal to the contactor causing it to close thus making power continuity.

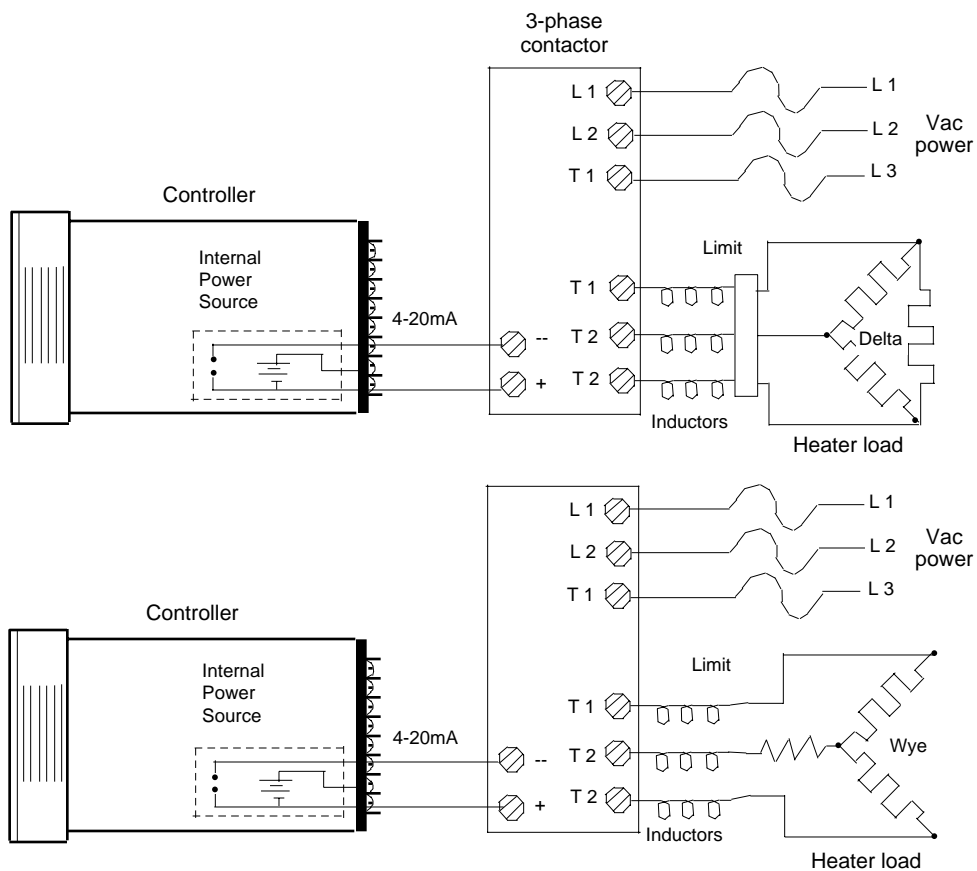

Application Guide for Power Controls

POWER CONTROLS

There are four standard power controls: electromechanical relays, mercury displacement relays, solid state relays and silicon control rectifiers (SCRs). The first two use magnetic devices to activate power switching. The other two use solid state electronics to switch the power.

ELECTROMECHANICAL CONTACTOR

The electromechanical contactor, or mechanical relay is an electrical and mechanical device with moving parts. When power is applied to the relay solenoid, contact closure is created through movement of the relay's common contact.

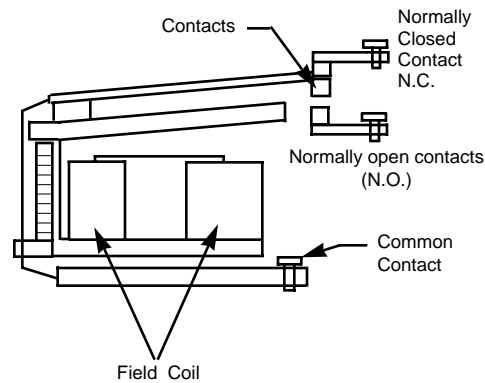

MERCURY DISPLACEMENT RELAY (MDR)

Mercury Displacement Relays have completely encapsulated contacts that rely on mechanical movement to function. The contacts do not wear, due to the mercury within the capsule. Mercury does not pit and burn like metal. Mercury displacement relays emit a barely audible noise when switching.

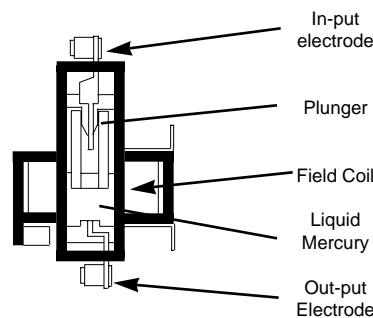

The Mercury Displacement Relay utilizes the best features of both the electromechanical relay and the solid state relay. The primary advantages of the electromechanical relay is its ability to switch considerable amounts of power at a low cost, coupled with the long life characteristics of a solid state relay. While the electromechanical relay costs less, the MDR will provide the long life desired. The Mercury Displacement Relay is rated to operate at full load for up to fifteen million cycles, giving it extended life comparable to solid state relays.

SOLID STATE RELAY (SSR)

Solid state relays have no moving parts and consequently, no mechanical failures. Solid state switches are resistant to shock and vibration. The absence of moving parts also makes them noise-free. The most important factor affecting its life is the ambient operating temperature. Failure to dissipate the heat generated by the solid state relay will quickly destroy it. Location and heat sinking must be adequate.

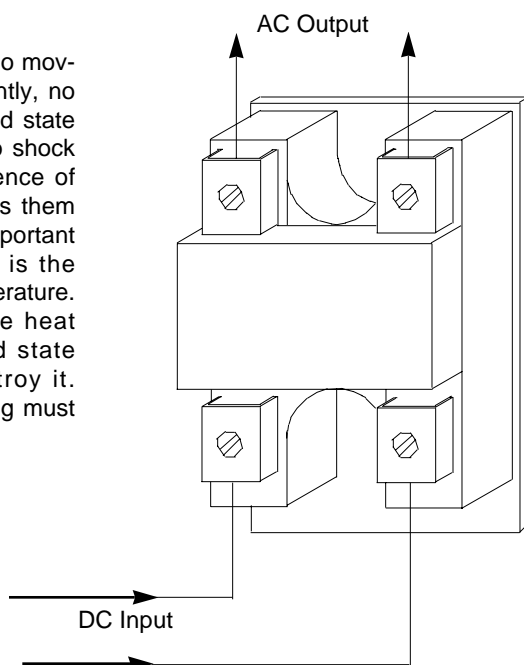

A typical solid state relay accepts a time proportioned or ON/OFF signal from a PID controller. Solid state relays switch near *zero volts*, which is "zero-cross firing."

Solid state relays have disadvantages which include the inability to provide a positive circuit break, the initial cost, and their failure when subjected to overrated conditions. The failure modes include burnout of the switch if the system heater shorts out, reduction in switching capabilities as the ambient temperature rise, and susceptibility to failure caused by line transients and inductive loads.

Solid state relay life can be extended by a great degree with proper fusing for overload conditions and increasing the heat sinking for high ambient temperatures.

SILICONE CONTROLLED RECTIFIER (SCR)

The silicone rectifier is a solid state switching device that can switch up to a 1200 Amp load.

Most power controls can accept two types of input signals: time proportioned (or ON/OFF) and process signals (either 4-20 mA or 1-5VDC) from any temperature control. SCR's accepting time proportioned (or ON/OFF) signals are called "power contactors."

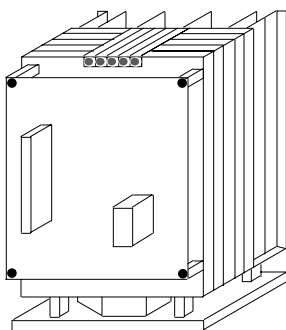

SCR's accepting process signals (4-20mA or 1-5VDC) are called "power controls." They control the power by two methods of firing, *phase angle* and *zero cross (burst) firing*. The primary advantages of SCR power controls are lack of moving parts, long life, improved controllability, very large current handling capability, and input signal flexibility.

Glossary

AC -- An electric current that reversed its direction of flow at regularly recurring intervals.

Alumel™ -- An aluminum nickel alloy used in the negative leg of a Type K thermocouple. This a trademark of the Hoskins Manufacture Company.

Ambient Temperature -- The temperature of air or other medium surrounding the components of thermal system. Pertaining to instruments, it is the temperature they are exposed to inside the control panel.

Ampere (amp, current) -- A unit that defines the rate of charge flow in a circuit. Amp units are equal to one coulomb per second.

Annealing -- The process of heating a material just below its heat distortion point to relieve stresses.

ANSI -- The American National Standard Institute.

ASME -- The American Society of Mechanical Engineers.

ASTM -- The American Society for Testing and Materials.

Atmospheric pressure -- The pressure exerted by the atmosphere. Standard atmospheric pressure is 14.7 psia (1 atmosphere) at sea level and 60°F.

AWG -- American Wire Gauge standards.

BTU -- British Thermal Unit. A unit of energy defined as the amount of heat require to raise 1 lb of water form 32°F at standard atmospheric pressure. OneBTU is equal to 0.293 watt-hours. One kilowatt-hour is equal to 3412 BTUs.

Calibration -- The act of adjusting an instrument to a know value. This value may be a physical traceable to an international standard.

Celsius -- Formerly know as centigrade. A temperature scale with water's ice point at 0°C and its boiling point at 100°C at standard atmospheric pressure. The formula for conversion to the Fahrenheit scale is: °F = (1.8 x °C) + 32

Chromel® -- A chromium-nickel alloy which makes up the positive leg of Type K and E thermocouples. This is a registered trademark of the Hoskins Manufacturing company.

Conduction -- The mode of heat transfer within a substance or by solids in direct contact with each other when a temperature difference exists.

Constantan -- A copper-nickel alloy used as the negative lead in Type E, J, and T thermocouples.

Convection -- The mode of heat transfer associated with conduction in which heat is transferred from a higher temperature region in a liquid to a lower temperature region as a result of movement of masses of the fluid.

C - UL -- Underwriter's Laboratory testing certification covering CSA (Canadian Standard Association).

CSA -- Canadian Standard Association.

DC (Direct Current) -- An electrical current flowing in one direction.

Delta -- An electrical network where loads are connected directly between the three phases.

Density -- Mass per unit volume of a substance usually expressed in lbs/ft³ or grams/cm³. Also known as specific weight. Density remains nearly constant for solids and most liquids under ordinary conditions of temperature and pressure. Gas density changes with temperature and its reference is taken of standard condition of 60°F/15°C and standard atmospheric pressure.

Dielectric -- A material with low electrical conductivity, commonly called an electrical insulator.

DIN -- Deutsche Industrial Norm. A set of technical/scientific and dimensional standards developed by an organization in Germany. Many DIN standards have worldwide recognition.

Emissivity -- The ratio of radiation emitted form a surface compared to a blackbody at the same temperature with similar spectral and directional conditions (See infrared and radiation.)

Energy -- Power per unit of time. In the USA, energy is measured in BTU or KWH.

Fahrenheit -- The temperature scale defined with an ice point for water at 32°F and a boiling point of 212°F at standard atmospheric pressure. The formula for conversion to Celsius is:
°C = 5/9 (°F - 32)

Ground -- An electrical line having the same electrical potential as the surrounding earth. Grounding an electrical system is usually employed to protect people and equipment from shocks due to malfunctions. Also referred as "safety ground."

Ground Junction -- A type of thermocouple probe construction where the hot, or measuring junction, is an integral part of the sheath material. No electrical isolation is provided on a grounded junction.

Heat -- Energy transferred between substances as a result of a temperature difference between them.

Heat Sink -- A finned piece of metal (usually aluminum) used to dissipate heat generated by a solid state relay or SSR.

Heat Transfer -- The process of heat energy flowing from one body of higher temperature of one of lower temperature.

Hertz(Hz) -- Frequency, measured in cycles per second.

Hi-Pot Test -- A test which applies a high voltage to a conductor to assure the integrity of the surrounding insulation.

Hydroscopic -- Describes a material that absorbs moisture.

ID -- Abbreviation for inside diameter.

Infrared -- An area in the electromagnetic spectrum range from 1 to 1000 microns. Heat is transferred in this range.

Kelvin (K) -- an absolute temperature scale. Zero Kelvin is absolute zero -- the temperature where all molecular activity stops. No degree symbol (°) is used with the Kelvin scale. (0°C = 273.15 K, 100° = 373.15 K)

Kilowatt (KW) -- Electrical unit of power equal to 1000 watts or 3412 BTUs per hour when the power factor equals 1.0.

Kilowatt Hour (KWH) -- Electrical unit of energy, or work, expended by one kilowatt in one hour. Also expressed as 1000 watt hours.

Laminar Flow -- A condition where the plastic resin moves in continuous parallel paths.

Linearity -- The deviation in response from an expected or theoretical straight line value for instruments and transducers.

Load -- The electrical demand (expressed in power [watts], current [amps] or resistance [ohms]) of a process.

Mass Flow Rate -- the amount of a substance flowing per unit of time past a given cross-section area within a conduit.

Maximum Operating Temperature -- The highest temperature at which a device can operate safely, or with expected normal service life.

Maximum Power Rating -- The maximum operating power a device can handle without danger or a shortened operating life.

Mega -- A prefix meaning million. The symbol is "M".

MgO -- The chemical symbol for magnesium oxide which is a good conductor of heat and a good electrical insulator.

Milliamp (mA) -- One thousandth of an ampere.

Microvolt (µV) -- One millionth of a volt.

Millivolt (mV) -- One thousandth of a volt.

NEMA -- The National Electrical Manufacturers Association.

NPT -- The National Pipe Thread standards.

OD -- Abbreviation for outside diameter.

PID -- Proportional, Integral, Derivative. A control mode with three functions. Proportional action dampens the system response, integral corrects for droop, derivative seeks to prevent overshoot and undershoot.

Polarity -- The electrical quality of having two opposite poles, one positive and one negative. Polarity determines the direction in which a current tends to flow.

Positive Temperature Coefficient -- A resistance increase occurring with a temperature increase (see RTD or Thermistor).

Pressure -- Force per unit area, usually expressed in pounds per square inch (psi)

Pressure Drop -- The difference in pressure between any two points of a system or component.

PSIA -- Pounds per square inch absolute. Pressure expressed in terms of its actual or absolute value with reference to a perfect vacuum.

PSIA = PSIG + 14.7 psi (1 atmosphere)

PSIG -- Pounds per square inch gauge. Pressure expressed in terms of a value read directly from installed gauges.

PSIG = PSIA - 14.7 psi (1 atmosphere)

Radiation -- The process of emitting radiant energy in the form of waves or particles (see Emissivity and Infrared).

Relay, Electromechanical -- A power switching device that completes or interrupts a circuit by physically moving electrical contacts into contact with each other. Also called relay.

Relay, Mercury Displacement -- A power switching device using mercury, when displaced by a plunger, to complete the electric circuit across contacts.

Relay, Solid State -- A solid state switching device that completes or interrupts an electric circuit with no moving parts (see SSR.)

Resistance -- Opposition to the flow of electric current measured in ohms.

RTD -- Resistive Temperature Detector. A temperature sensor whose resistance increases with increasing temperature in a known manner. Platinum is the most commonly used in RTD material.

SCFM -- Standard volumetric flow rate in cubic feet per minute. Normally used for gases and vapors, this value is evaluated at standard condition of 60°F/15°C and standard atmospheric pressure.

SCR -- Silicon Controlled Rectifier. A solid state device, or thyristor, having no moving parts, that when used in pairs, controls AC voltages within one cycle. SCRs control voltage from a power source to the load by burst (zero cross) or phase angle firing.

Sensor -- A device which detects the temperature, pressure or other physical property of a controlled media, and provides an output signal to an automatic controller or switching mechanism.

Set Point -- The desired value programmed into a control.

SI system of units -- A system of measurement adopted by the Eleventh General Conference of Weights and Measures in 1960 and derived from the metric system. This system is called Le Systeme International d'Unites (abbreviated SI)



Soft Start -- A method of using phase angle control to gradually increase the output power over a period of several seconds. Used for heaters with a low electrical resistance when cold or for limiting in-rush current to inductive loads.

Specific Gravity (sp.gr.) -- Density, compared to the density of water, which is given the arbitrary value of 1 to 0°C (see Density).

Specific Heat -- The term used to express the capacity of a substance to gain or lose heat energy as its temperature changes. It is expressed in units of BTU/lb -°F or Joules/grams - °C. Specific heat varies in most materials with changes in temperature and material state.

SSR -- Solid State Relay. A solid state switching device that switches current ON and OFF. It has no moving parts.

Swaging -- A sheathed electrical element manufacturing process when the element sheath is hammered in a die to reduce its diameter and compact its insulation.

Temperature -- The hotness or coldness of a body measured on a definitive scale (normally degrees Fahrenheit, Celsius, Rankine or Kelvin).

Thermal Conductivity -- A property which indicates a material's ability to transfer heat. The higher a material's thermal conductivity, the quicker it will transfer heat energy. It's expressed in BTU/hr - ft. -°F or watts/meter - °C. This value changes with temperature in most materials and must be evaluated for the condition given.

Thermal Expansion -- A size increase in a material resulting from a rise in temperature. It's expressed as the number of inches/inch/°F or centimeters/cm/°C per reference length.

Thermistor -- A contraction for Thermally Sensitive Transistor. It's a temperature sensing device composed of semiconductor material which exhibits a large change in resistance for a small change in temperature. Thermistors usually have negative temperature coefficients.

Thermocouple -- A temperature sensing device constructed by joining two dissimilar metals. This junction produces an electrical voltage in proportion to the difference in temperature between the hot junction and the lead wire connection to the sensing device (cold junction).

Thermocouple Junction -- The point in a thermocouple where the two dissimilar metals, or legs, are joined. In a typical thermocouple circuit, there is a measuring junction and a reference junction.

Thermoplastic Materials -- Become soft and moldable when heated and change back to solids when allowed to cool. Thermoplastic materials that are flexible even when cool are known as elastomer or TPEs. Although the heating/cooling cycle can be repeated, recycling reduces mechanical properties and appearance.

Thermostat -- An electro-mechanical device which opens or closes a contact at a specified temperature. The most common forms of thermostat are bulb and capillary and bi-metal strip.

Thermowell -- A closed end tube designed to protect temperature sensors from hostile environments.

Transducer -- A device which receives a signal in one form and retransmit it in another form, i.e. a thermocouple transforms heat energy input into a voltage output.

Turbulent Flow -- A condition where the plastic resin particles move in random paths, rather than in a continuous parallel paths.

UL -- Underwriters Laboratories, Inc.® 333 Pfingsten Road, Northbrook, Illinois, 60062-2096, USA. An independent testing laboratory that establishes commercial and industrial standards. It also tests and certifies products against those standards.



UL components recognition.



C-UL (CSA equivalent) components recognition.

Ungrounded Junction -- A form of thermocouple probe construction where the measuring junction is fully enclosed in a protective sheath, and is electrically isolated from the sheath.

Viscosity -- The fluid property which determines the amount of its resistance to shearing forces (flow). High viscosity indicates a tendency for fluid to flow or move slowly. The viscosity for fluids decrease as their temperatures increase. Heating gases will increase their absolute viscosity.

Volt Amperes -- Represented by the symbol "VA". A measurement of apparent power. The product of voltage and current in a reactive circuit.

$$V \text{ (voltage)} \times I \text{ (current)} = \\ VA \text{ (volt-amperes)}$$

The unit volt-ampere is used instead of watts, since the term watt is reserved for real power.

Volt/Voltage (V) -- The unit of electromotive force (EMF), the difference in electrical potential between two points in a circuit, it's the "push" or "pressure" behind current flow through a circuit. One volt is the difference in potential required to move one coulomb of charge between two points in a circuit consuming one joule of energy. Expressed another way, one volt (V) is equal to one ampere of current (I) flowing through one ohm of resistance (R), or $V = IR$.

Watt (W) -- A measurement of real power. The product of voltage and current in a resistive circuit.

$$V \text{ (voltage)} \cdot I \text{ (current)} = \\ P \text{ (power in watts)}$$

Watt Density -- The power produced in watts per unit surface area of heater. It indicates the potential for a surface to transmit heat energy and is expressed in W/in^2 . Ratings for heating elements and surface heat loss factors are expressed using this value.

Wye -- An electrical connection when one end of three loads is connected together and the other end to one each of the three phases of a power supply.