



Model 18TBP/TB

- **Description:** Variable-Voltage Power Control
- **Product Range:** 120-240 VAC, 5-25 amps.
- **Application:** Resistance Loads

### FEATURES

- All Solid-State Construction
- Short Circuit Protection
- Integral Heatsink Chassis
- No Thermal Derating

### TYPICAL APPLICATIONS

- Replace Variable Transformers
- Electric Heater Control
- Light Dimming
- Hot-Wire Cutting
- Heat Sealing and Packaging
- Plastic Molding and Extruding
- Food Preparation Equipment

Model 18TBP/TB controls provide infinitely variable control of single-phase a.c. voltage to resistive heating elements. These controls are solid-state replacements for variable transformers, mercury relays, saturable core reactors, and electromechanical contactors. Power Triacs replace contacts and brushes to control electric power without moving parts, and, when operated within their stated ratings for current, voltage, and temperature, have no known MTBF or life expectancy rating.

### PANEL- OR CHASSIS-MOUNT

Model 18TBP controls are compact, lightweight packages that employ single hole mounting to panels and enclosure doors. Model 18TB controls are designed for rear or rack mounting. Both utilize an electrically isolated heatsink chassis.

### EXCLUSIVE ADVANCED TECHNOLOGY:

#### Three Pillars Of Protection

Model 18TBP/TB controls incorporate exclusive design features to protect power semiconductor components against damage. "2 millisecond" fuses protect against short-circuit damage; an R-C snubber network protects against dv/dt failure; an integral heatsink chassis allows continuous operation in ambients to 50°C with no derating.

### SPECIFICATIONS

**Power Circuit:** power Triac with parallel R-C circuit for dv/dt protection and current-clamping 2 millisecond fuse for short-circuit protection.

**Control Circuit:** R-C network with variable-resistance potentiometer adjusts firing capacitor into bilateral diode connected to power Triac gate for stable, full-range control.

**Mains Frequency:** 50/60 Hz.

**Output Voltage:** 0-95% of input.

**Overall Efficiency:** 99%.

**Power Loss:** approximately 1.5 watts/amp.

**Voltage Drop Across Power Circuit at 100% Output:** 1-2 volts maximum/phase.

**Control Input:** manual control via variable potentiometer.

**Control Power:** 1 watt.

**Fuse Protection:** 2 millisecond I<sup>2</sup>t fuses are factory tested and coordinated with all power semiconductors, considering:

- a. fuse element melt time  $t_{melt}$ ;
- b. peak melt current  $I_{melt}$ ;
- c. arc quench time  $t_{arc}$ ;
- d. peak arc current  $I_{arc}$ .

**Ambient Temperature Range:** 10 to +50°C.

**Terminal Connections:** Bakelite or thermoplastic blocks.

### SIZING CONSIDERATIONS

Model 18TBP/TB controls are rated for use with constant resistance loads. Size units by actual load current, not kW.

- 1> Always use maximum possible load current for sizing purposes.
- 2> The amp rating is determined by the fuse. Current draw must not exceed the fuse rating at any time.
- 3> Rated voltage of connected load should match control input voltage.

### SIZING EXAMPLE

**Applications:** single-phase, 800 watt nichrome heating element; input voltage 120 VAC, 60 Hz.

#### Model Number Selection:

- a. Triac-based variable-voltage: SC
- b. Panel-mount: E
- c. 120 VAC input: 12
- d. Amp rating, calculated as follows:  
 $800 = 6.66$  amps  
120

Since  $6.66 < 10$ , amp rating: -10

**Model Number:** SCE12-10.

### WHEN ORDERING, SPECIFY:

- Model Number
- Input Voltage
- Load Specifications

**PERFORMANCE NOTE:** Triac power circuits may "slave" when multiple units are used on 240 VAC lines derived from three phase mains. For optimum performance, use on single phase, 240 VAC derived from 3-wire, 120/240 VAC mains.

Model Number	Max. Amps	KVA @ Max. Rated Voltage	Fuse Number	OPEN CHASSIS DIMENSIONS Inches (millimeters)		
				Height	Width	Depth
Single-Phase, 120 VAC, 50/60 Hz Input, 0-118 VAC Output						
18TBP-1-5	5	0.6	49C25-10	3.2 (81)	2.5 (64)	2.5 (54)
18TBP-1-10	10	1.2	49C25-10	3.2 (81)	2.5 (64)	2.5 (54)
18TBP-1-15	15	1.8	49C25-15	3.2 (81)	2.5 (64)	2.5 (54)
18TB-1-15	15	1.8	49C25-15	4 (102)	4 (102)	2.6 (66)
18TB-1-25	25	3.0	49B25-30	6 (152)	4 (102)	2.75 (70)
Single-Phase, 208/220/240 VAC Input, 0-206/218/238 VAC Output						
18TBP-2-5	5	1.2	49C25-10	3.2 (81)	2.5 (64)	2.5 (54)
18TBP-2-10	10	2.4	49C25-10	3.2 (81)	2.5 (64)	2.5 (54)
18TBP-2-15	15	3.6	49C25-15	3.2 (81)	2.5 (64)	2.5 (54)
18TB-2-15	15	3.6	49C25-15	4 (102)	4 (102)	2.6 (66)
18TB-2-25	25	6.0	49B25-30	6 (152)	4 (102)	2.75 (70)

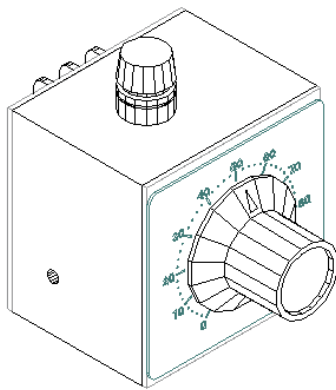

MODEL 18TBP

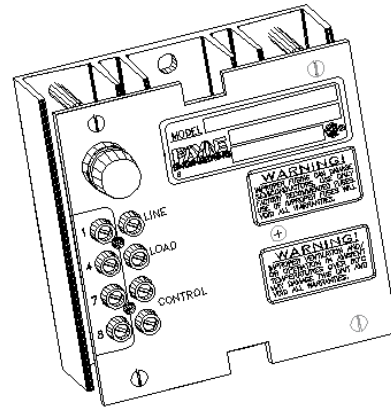

MODEL 18TB

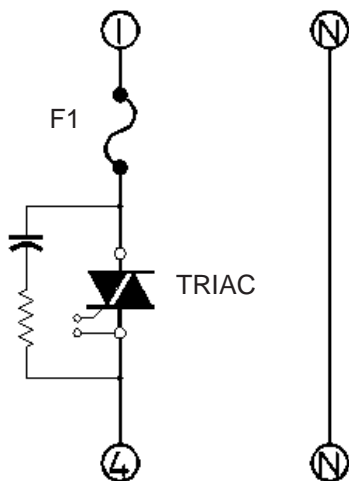

POWER CIRCUIT SCHEMATIC

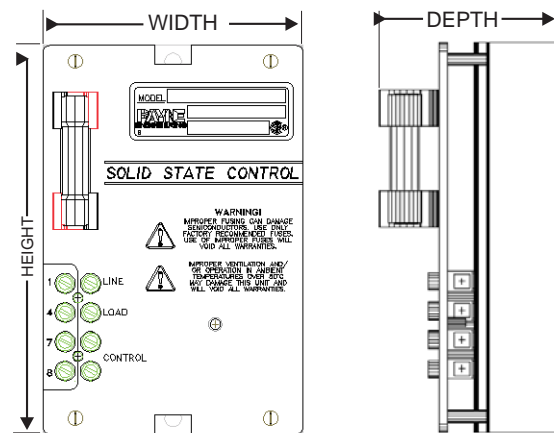

OPEN CHASSIS DIMENSION

All dimensions are approximate, and are not to be used for construction purposes. Payne Engineering Company Inc. reserves the right to make changes to product design, construction, and component parts in the interest of technical advancement without prior notification.